



Structural Calculations

Prepared For:
Work Order:
Date:

Project Abstract:

New multi-use building.

Residential Upper Floors: Wood Framed

Commercial Main Floor: Steel, Concrete and Wood

Table of Contents

Structural Calculations

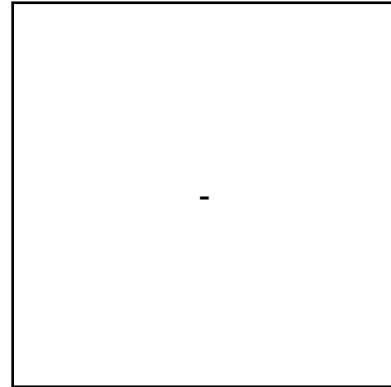

Prepared For:
Work Order:
Date:

Subject	Page
<i>General Project Information</i>	
Loading Criterion	1 to 5
<i>Lateral Force Resisting System</i>	
SW Layout	6 to 9
SW Design – Wood Framing	10 to 62
Store Front - Steel Frame	63 to 68
Garage Entry – Concrete Columns	69 to 72
<i>Vertical Force Resisting System</i>	
Wood Beam & Header Design	73 to 115
Steel Beam Designs	116 to 121
Steel Beam to Beam Connection	122
Steel Column	123 to 125
High-Capacity Pier Pads	126 to 137

Grays Harbor County Design Criteria

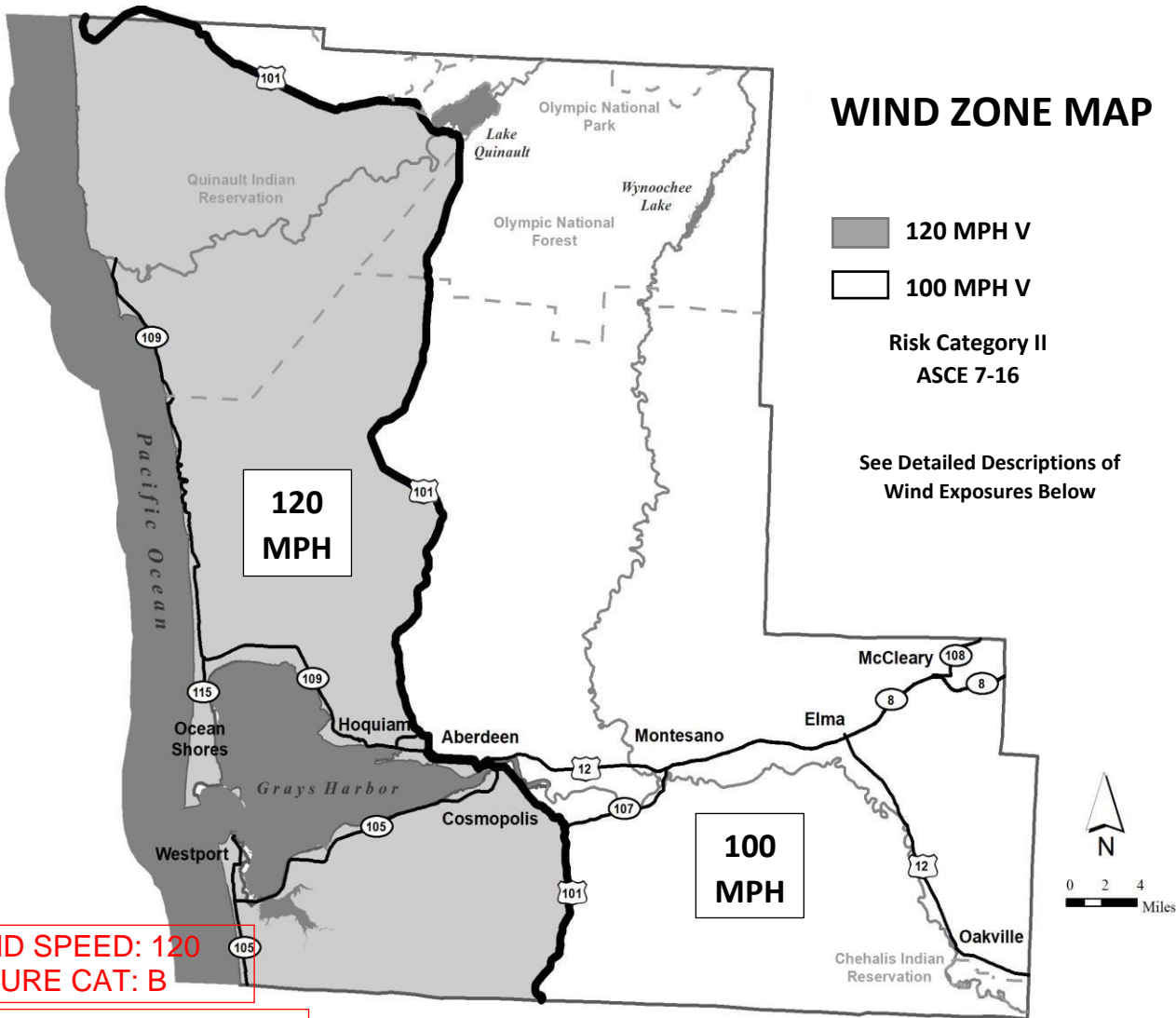

GROUND SNOW LOAD	WIND DESIGN				SEISMIC DESIGN CATEGORY	SUBJECT TO DAMAGE FROM			WINTER DESIGN TEMP	ICE BARRIER UNDERLAYMENT REQUIRED	FLOOD HAZARDS	AIR FREEZING INDEX	MEAN ANNUAL TEMP
	Speed (mph)	Topographic effects	Special wind region	Wind-borne debris zone		Weathering	Frost line depth	Termite					
25 psf	120/100	NO	YES	NO	D2	MODERATE	12"	NO	24°	NO	9/18/20	250	50°

Exposure B. For buildings with a mean roof height of less than or equal to 30 feet (9144 mm), Exposure B shall apply where the ground surface roughness, as defined by Surface Roughness B, prevails in the upwind direction for a distance of not less than 1,500 feet (457 m). For buildings with a mean roof height greater than 30 feet (9144 mm), Exposure B shall apply where Surface Roughness B prevails in the upwind direction for a distance of not less than 2,600 feet (792 m) or 20 times the height of the building, whichever is greater.

Exposure C. Exposure C shall apply for all cases where Exposure B or D does not apply.

Exposure D. Exposure D shall apply where the ground surface roughness, as defined by Surface Roughness D, prevails in the upwind direction for a distance of not less than 5,000 feet (1524 m) or 20 times the height of the building, whichever is greater. Exposure D shall apply where the ground surface roughness immediately upwind of the site is B or C, and the site is within a distance of 600 feet (183 m) or 20 times the building height, whichever is greater, from an Exposure D condition as defined in the previous sentence.

ASCE Hazards Report

Address:
No Address at This Location

Standard: ASCE/SEI 7-16
Risk Category: III
Soil Class: D - Default (see Section 11.4.3)

Latitude: 47.194776
Longitude: -124.199182
Elevation: 101.48183266342903 ft (NAVD 88)

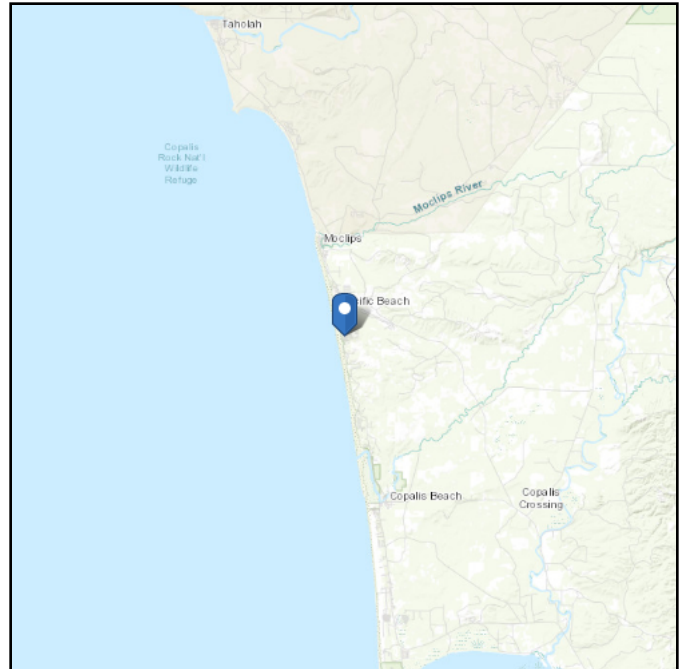
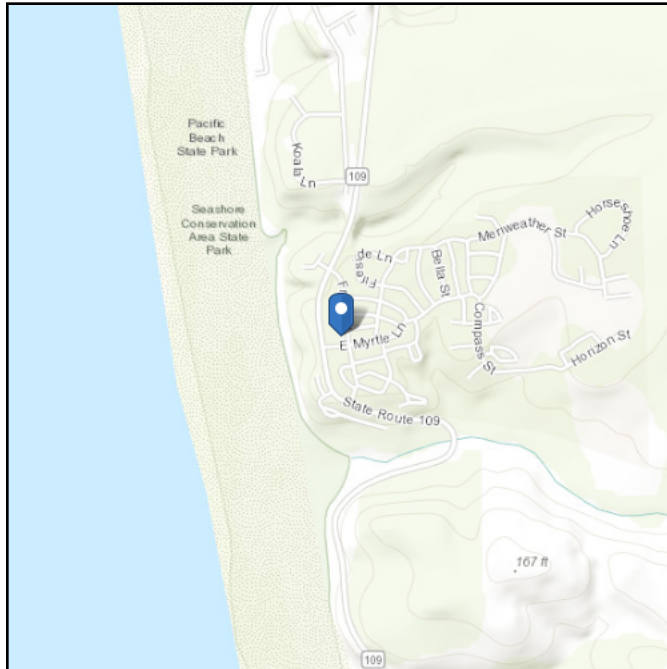

Wind

Results:

Wind Speed	102 Vmph
10-year MRI	66 Vmph
25-year MRI	71 Vmph
50-year MRI	76 Vmph
100-year MRI	81 Vmph
Special	

**DESIGN WIND SPEED: 120
MPH EXPOSURE CAT: B**

Special Wind Region -- Mountainous terrain, gorges, and special wind regions shown in Fig. 26.5-1 shall be examined for unusual wind conditions. The Authority Having Jurisdiction shall, if necessary, adjust the values given in Fig. 26.5-1 to account for higher local wind speeds. Such adjustment shall be based on meteorological information and an estimate of the basic wind speed obtained in accordance with the provisions in Section 26.5.3.

Data Source: ASCE/SEI 7-16, Fig. 26.5-1C and Figs. CC.2-1–CC.2-4, and Section 26.5.2
Date Accessed: Thu Aug 28 2025



Value provided is 3-second gust wind speeds at 33 ft above ground for Exposure C Category, based on linear interpolation between contours. Wind speeds are interpolated in accordance with the 7-16 Standard. Wind speeds correspond to approximately a 3% probability of exceedance in 50 years (annual exceedance probability = 0.000588, MRI = 1,700 years).

Site is not in a hurricane-prone region as defined in ASCE/SEI 7-16 Section 26.2.

Site Soil Class: D - Default (see Section 11.4.3)

Results:

S_s :	1.568	S_{D1} :	N/A
S_1 :	0.749	T_L :	16
F_a :	1.2	PGA :	0.775
F_v :	N/A	PGA _M :	0.93
S_{MS} :	1.882	F_{PGA} :	1.2
S_{M1} :	N/A	I_e :	1.25
S_{DS} :	1.254	C_v :	1.414

Ground motion hazard analysis may be required. See ASCE/SEI 7-16 Section 11.4.8.

Data Accessed: Thu Aug 28 2025

Date Source: [USGS Seismic Design Maps](#)

Snow

Results:

Ground Snow Load, p_g : 15 lb/ft²
Mapped Elevation: 101.5 ft

Data Source:

Date Accessed: Thu Aug 28 2025

Statutory requirements of the Authority Having Jurisdiction are not included.

Snow load values are mapped to a 0.5 mile resolution. This resolution can create a mismatch between the mapped elevation and the site-specific elevation in topographically complex areas. Engineers should consult the local authority having jurisdiction in locations where the reported 'elevation' and 'mapped elevation' differ significantly from each other.

**MINIMUM DESIGN SNOW LOAD:
25PSF**

The ASCE Hazard Tool is provided for your convenience, for informational purposes only, and is provided "as is" and without warranties of any kind. The location data included herein has been obtained from information developed, produced, and maintained by third party providers; or has been extrapolated from maps incorporated in the ASCE standard. While ASCE has made every effort to use data obtained from reliable sources or methodologies, ASCE does not make any representations or warranties as to the accuracy, completeness, reliability, currency, or quality of any data provided herein. Any third-party links provided by this Tool should not be construed as an endorsement, affiliation, relationship, or sponsorship of such third-party content by or from ASCE.

ASCE does not intend, nor should anyone interpret, the results provided by this Tool to replace the sound judgment of a competent professional, having knowledge and experience in the appropriate field(s) of practice, nor to substitute for the standard of care required of such professionals in interpreting and applying the contents of this Tool or the ASCE standard.

In using this Tool, you expressly assume all risks associated with your use. Under no circumstances shall ASCE or its officers, directors, employees, members, affiliates, or agents be liable to you or any other person for any direct, indirect, special, incidental, or consequential damages arising from or related to your use of, or reliance on, the Tool or any information obtained therein. To the fullest extent permitted by law, you agree to release and hold harmless ASCE from any and all liability of any nature arising out of or resulting from any use of data provided by the ASCE Hazard Tool.

Level 4 of 4

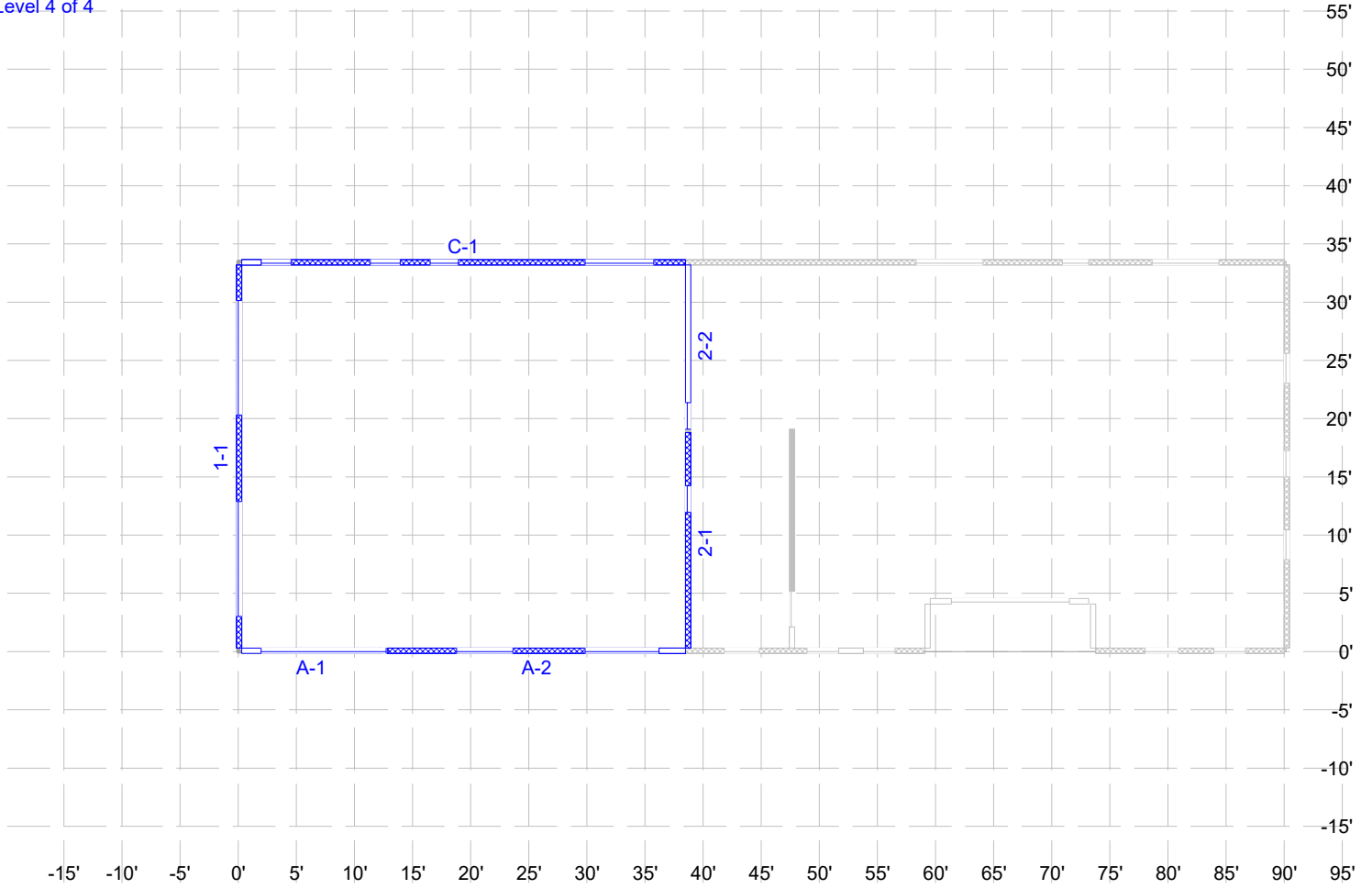

IES OF SSW.wswalls 13.1.2

Level 3 of 4

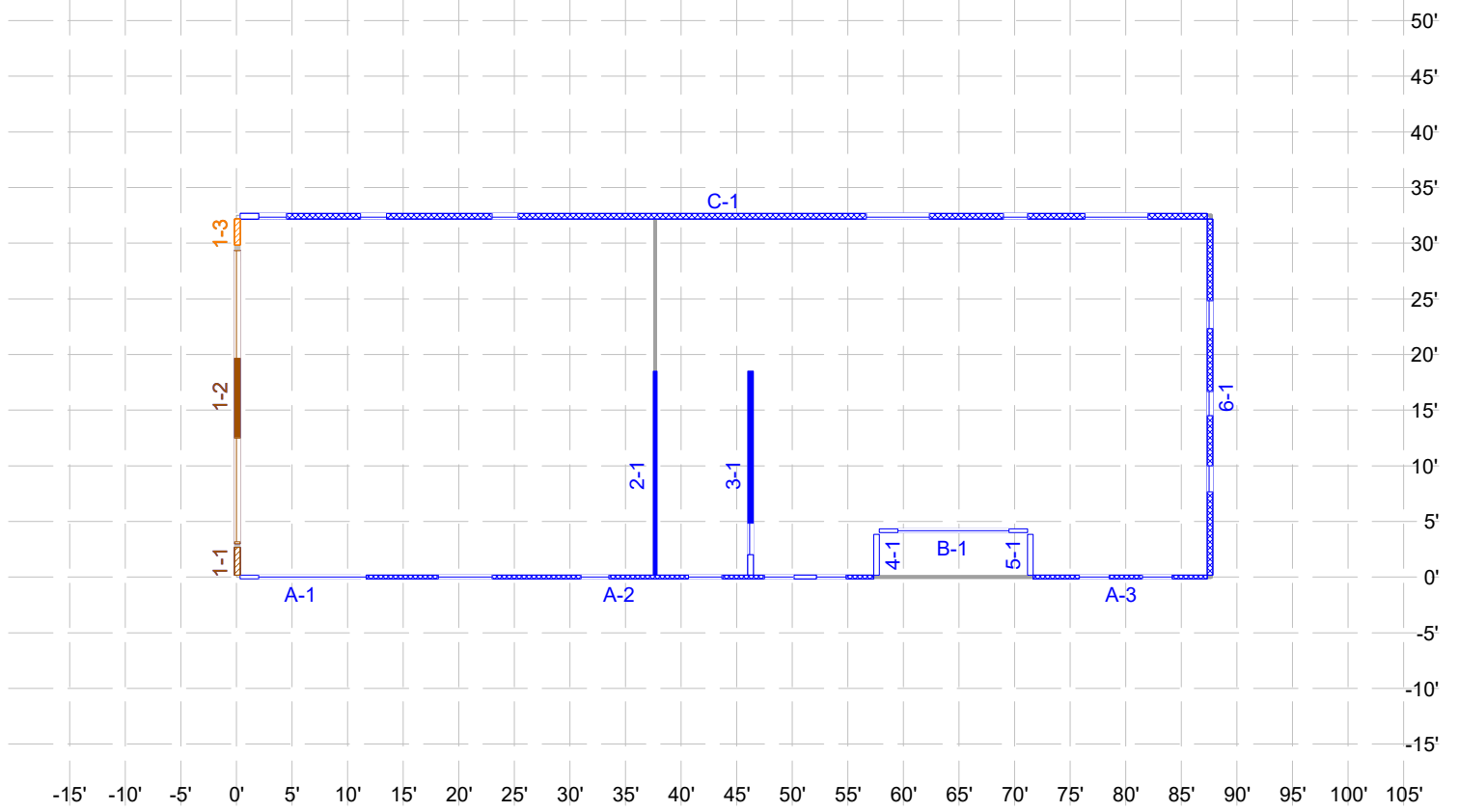

Level 2 of 4

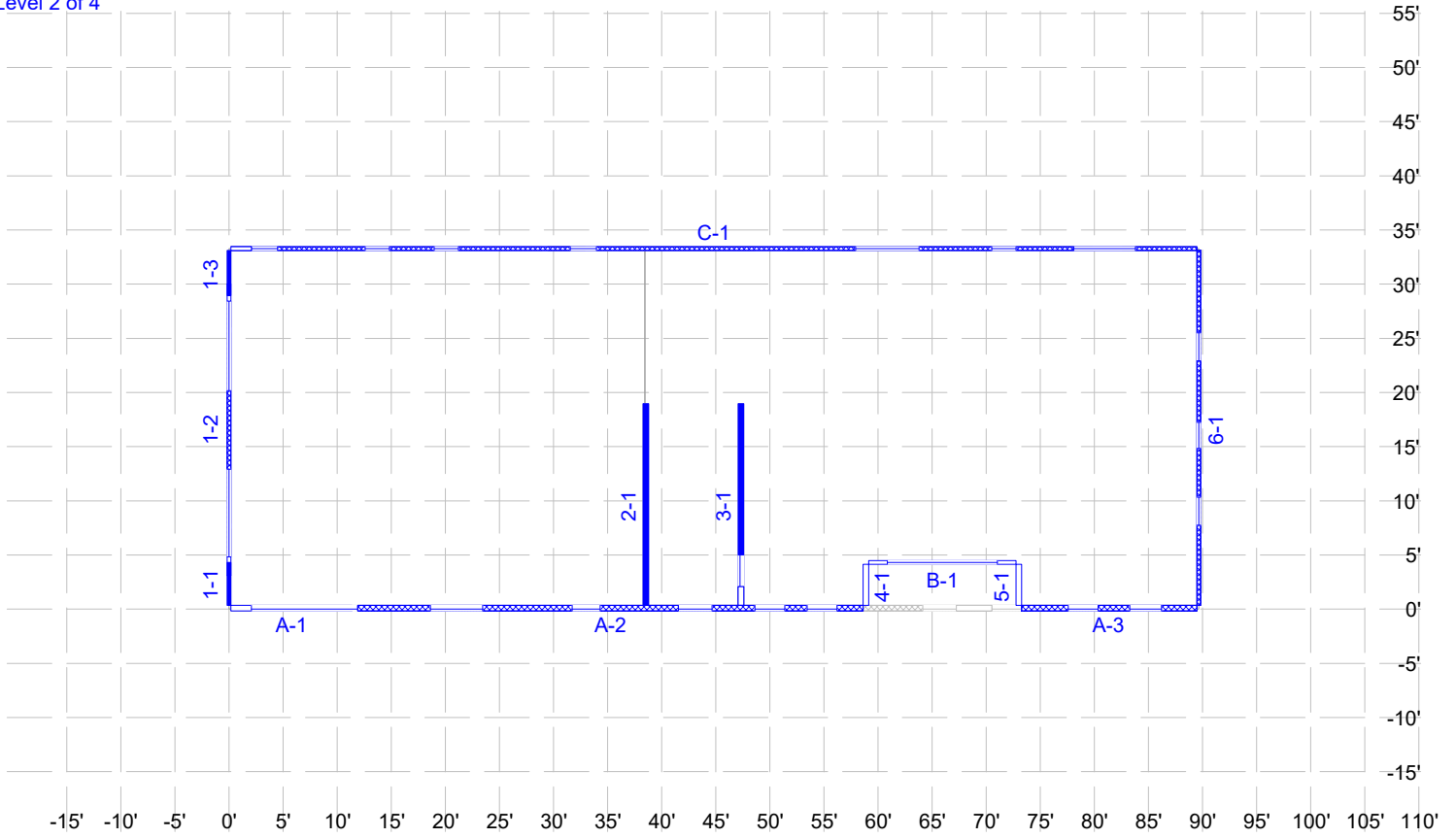

Level 1 of 4

MODELED AS A HIGH-CAPACITY
SHEARWALL FOR FORCE-COLLECTION.
SEE HAND CALCS FOR FINAL
SHEARWALL DESIGN

MODELED AS A HIGH-CAPACITY
SHEARWALL FOR
FORCE-COLLECTION. SEE
ENERCALC FOR STEEL FRAME

MODELED AS A HIGH-CAPACITY
SHEARWALL FOR
FORCE-COLLECTION. SEE
ENERCALC FOR REINFORCED
CONCRETE COLUMNS

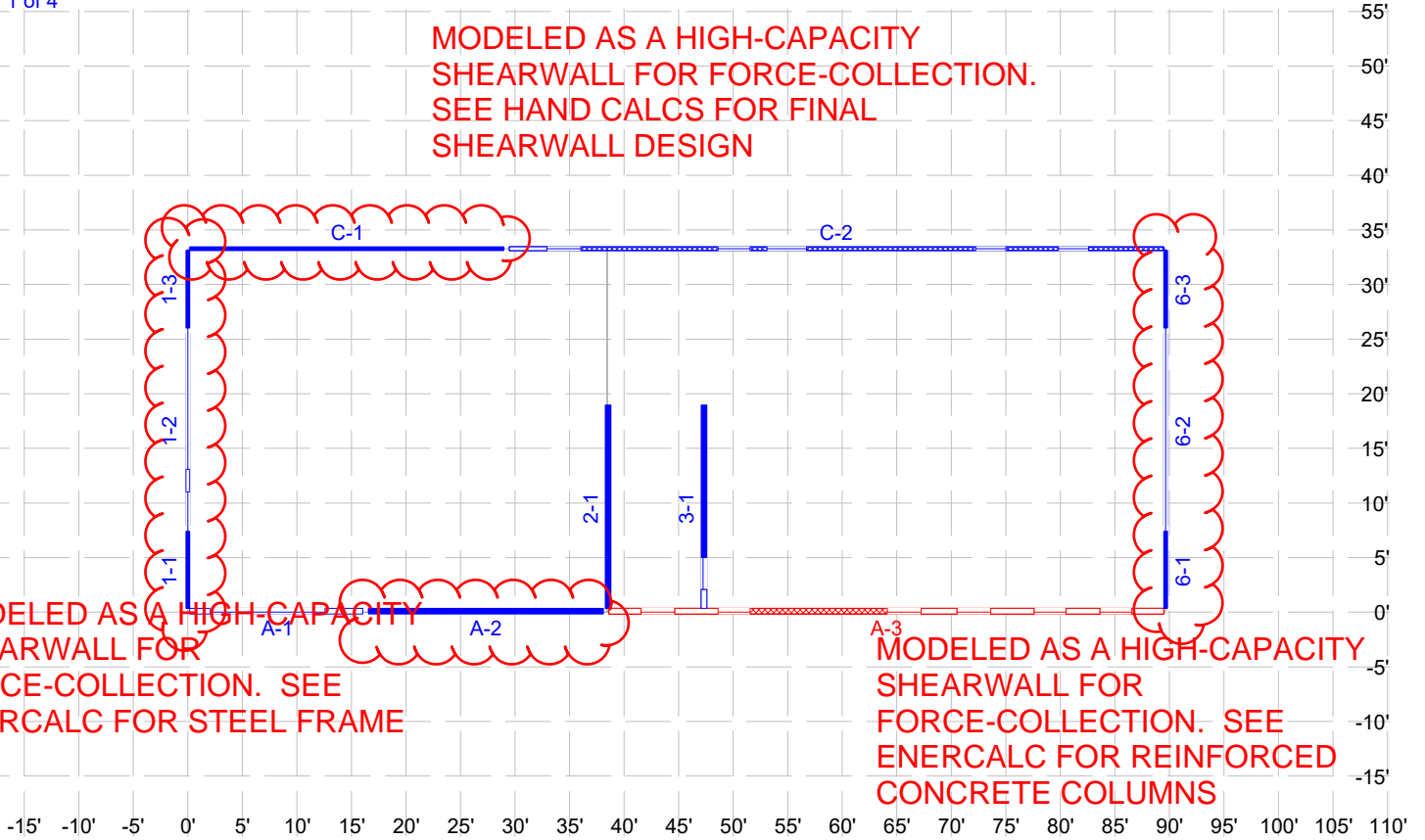

WoodWorks® Shearwalls 13.1.2

Project Information

COMPANY AND PROJECT INFORMATION

Company	Project
PLIRIS 3311 GULF BREEZE PKWY #149 GULF BREEZE, FL 32563	

DESIGN SETTINGS

Design Code		Wind Standard		Seismic Standard	
IBC 2021/AWC SDPWS 2021		ASCE 7-16 Directional (All heights)		ASCE 7-16	
Load Combinations			Building Code Capacity Modification		
For Design and MWFRS Deflection		For Deflection (Wind:Serviceability)		Wind	Seismic
0.7 Seismic + 0.6 Dead		1.0 Seismic + 0.9 Dead		1.00	1.00
0.6 Basic wind + 0.6 Dead		1.0 MRI wind + 1.0 Dead			
Service Conditions and Load Duration			Max Shearwall Offset [ft]		
Duration	Temperature	Moisture Content		Plan	Elevation
Factor	Range	Fabrication	Service	(within story)	(between stories)
-	-	15% (<=19%)	10% (<=19%)	4.00	1.00
Maximum Height-to-width Ratio					
Wood panels		Fiberboard	Lumber		Gypsum
Blocked	Unblocked		Wind	Seismic	Blocked Unblocked
3.5	2.0	-	-	-	2.0 1.5
Ignore shear resistance contribution of...			Forces based on...		
Wall segments		Seismic		Hold-downs	Applied loads
Side with invalid aspect ratio		Any gypsum, lumber, fiberboard		Drag struts	Applied loads
Shearwall relative rigidity: Deflection-based stiffness of wall segments					
Non-identical materials and construction on the shearline: Allowed, except for material type					
Deflection Equation: 3-term from SDPWS 4.3-1					
Drift limit for wind design: 1 / 500 story height					
FTAO strap: Continuous at top of highest opening and bottom of lowest					
Dead load in chord force for overturning design					
Tension end		Compression end		When completely counteracts overturning	
Wall length / 2		Wall length / 2		Wall length / 2	

SITE INFORMATION

Wind			Seismic		
ASCE 7-16 Directional (All heights)			ASCE 7-16 12.8 Equivalent Lateral Force Procedure		
Design Wind Speed	120 mph		Risk Category	Category II - All others	
Serviceability Wind Speed	95 mph		Structure Type	Regular	
Exposure	Exposure B		Building System	Bearing Wall	
Enclosure	Partially open		Design Category	E	
Min Wind Loads: Walls	16 psf		Site Class	D	
Roofs	8 psf		Spectral Response Acceleration		
Topographic Information [ft]			S1: 0.750g	Ss: 1.570g	
Shape	Height	Length	Fundamental Period	E-W	N-S
-	-	-	T Used	0.364s	0.364s
Site Location: -			Approximate Ta	0.364s	0.364s
Elev: 102ft			Maximum T	0.510s	0.510s
Flexible building, gust factor = 0.85			Response Factor R	6.50	6.50
Case 2	E-W loads	N-S loads	Fa: 1.00	Fv: 1.70	
Eccentricity (ft)	13.35	5.14			
Loaded at	75%				

WoodWorks® Shearwalls

Structural Data

STORY INFORMATION

	Story Elev [ft]	Floor/Ceiling Depth [in]	Wall Height [ft]	Hold-down Length subject to shrinkage [in]	Bolt length [in]
Ceiling	50.75	0.0			
Level 4	41.75	2'-0.0	9.00	27.6	28.35
Level 3	30.75	2'-0.0	9.00	27.6	28.35
Level 2	19.75	2'-0.0	9.00	27.6	28.35
Level 1	3.00	12.0	14.75	15.6	16.35
Foundation	2.00				

BLOCK and ROOF INFORMATION

Block Dimensions [ft]	Face	Roof Panels		Overhang [ft]
		Type	Slope	
Block 1				
Location X,Y =				
Extent X,Y =				
Ridge Y Location, Offset				
Ridge Elevation, Height				
Block 2				
Location X,Y =				
Extent X,Y =				
Ridge Y Location, Offset				
Ridge Elevation, Height				

WoodWorks® Shearwalls

SHEATHING MATERIALS by WALL GROUP

Grp	Surf	Material	Ratng	Sheathing					Gvtv lbs/in	Size	Fasteners					Apply Notes
				Thick in	GU in	Ply	Or	Size			Type	RS	Eg in	Fd in	Bk	
1	Both	Struct Sh OSB	24/16	7/16	-	-	Vert	83500	10d	Common	N	2	6	Y	2,7	
2	Ext	Struct Sh OSB	24/16	7/16	-	-	Vert	83500	8d	Common	N	6	12	Y	3	
	Int	Gyp. wallboard	24/16	1/2	-	1	Horz	40000	No. 6	Screw	N	8	12	Y	5	
3	Ext	Struct Sh OSB	24/16	7/16	-	-	Vert	83500	8d	Common	N	2	12	Y	2,3	
4	Ext	Struct Sh OSB	24/16	7/16	-	-	Vert	83500	8d	Common	N	3	12	Y	2,3	
	Int	Gyp. wallboard	24/16	1/2	-	1	Horz	40000	No. 6	Screw	N	8	12	Y	5	
5	Both	Struct Sh OSB	32/16	15/32	-	-	Vert	83500	10d	Common	N	2	12	Y	2,7	
6	Ext	Struct Sh OSB	32/16	15/32	-	-	Vert	83500	10d	Common	N	2	12	Y	2,7	
	Int	GSB 4x8	24/16	1/2	-	-	Horz	40000	11 ga	Galv	N	4	7	Y	5	
7	1	Struct Sh OSB	24/16	7/16	-	-	Vert	83500	8d	Common	N	3	12	Y	2,3	
8	1	Struct Sh OSB	24/16	7/16	-	-	Vert	83500	8d	Common	N	2	12	Y	2,3	
9	Ext	Struct Sh OSB	24/16	7/16	-	-	Vert	83500	8d	Common	N	4	12	Y	2,3	
	Int	Gyp. wallboard	24/16	1/2	-	1	Horz	40000	No. 6	Screw	N	8	12	Y	5	

Legend:

Grp – Wall Design Group number, used to reference wall in other tables (created by program)

Surf – Exterior or interior surface when applied to exterior wall

Ratng – Span rating, see SDPWS Table C4.2.3C

Thick – Nominal panel thickness

GU - Gypsum underlay thickness

Ply – Number of plies (or layers) in construction of plywood sheets

Or – Orientation of longer dimension of sheathing panels or lumber planks. Dbl. = Double diagonal.

Gvtv – Shear stiffness in lb/in. of depth from SDPWS Tables C4.2.3A-B

Type – Fastener type from SDPWS Tables 4.3A-D:

Common: common wire nail; Box: galvanized box nail; Casing: casing nail; Roof: galvanized roofing nail; Cooler: cooler nail; WBoard: wallboard nail; Screw: drywall screw; Gauge: nail measured by gauge; Galv: galvanized gauge nail; GWB: Gypsum wallboard blued nail

Size - From Tables 4.3A-D and Table A1; shown in Wall Input fastener dropdown

Common nails: 6d = 0.113 x 2", 8d = 0.131 x 2.5", 10d = 0.148 x 3", 12d = 0.148 x 3.5"

Box or casing nails: 6d = 0.099 x 2", 8d = 0.113 x 2.5", 10d = 0.128 x 3", 12d = 0.126 x 3.5"

Gauge, roofing and GWB nails: 13 ga = 0.92" x 1-1/8"; 11 ga = 0.120" x 1-1/8" (GWB nail for gypsum lath & plaster), 1-1/4" (gyp. L&P), 1-1/2" (wire lath & plaster, 1/2" fiberboard, 1/2" GWB), 1-3/4" (GSB, 5/8" GWB, 25/32" fiberboard, 2-ply GWB base), 2-3/8" (2-ply GWB face)

Cooler or wallboard nail: 5d = .086" x 1-5/8"; 6d = .092" x 1-7/8"; 8d = .113" x 2-3/8"; 6/8d = 6d base ply, 8d face ply for 2-ply GWB.

Drywall screws: No. 6, 1-1/4" long.

RS – Ring-shank nails (non-shearwalls only), with increased withdrawal capacity as per NDS 12.2.3.2.

Eg – Panel edge fastener spacing. For lumber sheathing, no. of nails per board at shear wall boundary. For 2-ply GWB, spacing of all nails in face ply.

Fd – Field spacing interior to panels. For lumber sheathing, no. of nails per board at interior studs. For 2-ply GWB, spacing of all nails in face ply.

Bk – Sheathing is nailed to blocking at all panel edges; Y(es) or N(o)

Apply Notes – Notes below table legend which apply to sheathing side

Notes:

2. Framing at adjoining panel edges must be 3" nominal or wider with staggered nailing according to SDPWS 4.3.7.1 (5)

3. Shear capacity for current design has been increased to the value for 15/32" sheathing with same nailing because stud spacing is 16" max. or panel orientation is horizontal. See SDPWS Table 4.3A Note 2.

7. Capacity has been reduced by a factor of 0.92 because of the use of hold-downs on walls with 10d nailing, as per Table 4.3A Note 10.

5. This material does not contribute to seismic shear resistance because the Design setting for ignoring contribution was set.

FRAMING MATERIALS and STANDARD WALL by WALL GROUP

Wall Grp	Species	Grade	b in	d in	Spcg in	SG	E psi^6	Fcp	Standard Wall
1	D.Fir-L	Stud	1.50	5.50	24	0.50	1.40	625	2/6B_SEG_OSB_7/16_8D_24 2
2	D.Fir-L	Stud	1.50	5.50	16	0.50	1.40	625	6/12B_PERF_OSB_7/16_8D
3	MSR D.Fir-L	900f-1.0E	1.50	5.50	16	0.50	1.00	625	2/12B_PERF_OSB_7/16_8D 3
4	D.Fir-L	Stud	1.50	5.50	16	0.50	1.40	625	3/12B_PERF_OSB_7/16_8D
5	D.Fir-L	Stud	1.50	5.50	16	0.50	1.40	625	2/12B_SEG_OSB_15/32_10D_BS
6	D.Fir-L	Stud	1.50	5.50	16	0.50	1.40	625	2/12B_SEG_OSB_15/32_10D
7	D.Fir-L	Stud	1.50	5.50	16	0.50	1.40	625	3/12B_SEG_OSB_7/16_8D
8	D.Fir-L	Stud	1.50	5.50	16	0.50	1.40	625	2/12B_SEG_OSB_7/16_8D
9	D.Fir-L	Stud	1.50	5.50	16	0.50	1.40	625	4/12B_PERF_OSB_7/16_8D

Legend:

Wall Grp – Wall Design Group

b – Stud breadth (thickness)

d – Stud depth (width)

Spcg – Maximum on-centre spacing of studs for design, actual spacing may be less.

SG – Specific gravity

WoodWorks® Shearwalls

E – Modulus of elasticity

Standard Wall - Standard wall designed as group.

F_{cp} - Compressive strength perpendicular to grain

Notes:

Check manufacture requirements for stud size, grade and specific gravity (G) for all shearwall hold-downs.

The following factors are applied to F_{cp} for compressive design and deformation under wall segment end studs :

Bearing area factor C_b from NDS 3.10.4, under window openings.

WoodWorks® Shearwalls

SHEARLINE, WALL and OPENING DIMENSIONS

North-south Shearlines	Type	Wall Group	Location X [ft]	Extent [ft]		Length [ft]	FHS [ft]	Aspect Ratio	Height [ft]	Studs	
				Start	End					S	N
Line 1											
Level 4											
Line 1		7	0.00	0.00	33.00	33.00	13.50	-	9.00	-	-
Wall 1-1	Seg	7	0.00	0.00	33.00	33.00	13.50	-	-	2	2
Segment 1		-	-	0.00	3.00	3.00	2.75	3.00	-	2	2
Opening 1		-	-	3.00	12.75	9.75	-	-	8.00	2	2
Segment 2		-	-	12.75	20.00	7.25	7.00	1.24	-	2	2
Opening 2		-	-	20.00	29.75	9.75	-	-	8.00	2	2
Segment 3		-	-	29.75	33.00	3.25	3.00	2.77	-	2	2
Level 3											
Line 1		6	0.00	0.00	33.00	33.00	13.50	-	9.00	-	-
Wall 1-1	Seg	6	0.00	0.00	33.00	33.00	13.50	-	-	2	2
Segment 1		-	-	0.00	3.00	3.00	2.75	3.00	-	2	2
Opening 1		-	-	3.00	12.75	9.75	-	-	8.00	2	2
Segment 2		-	-	12.75	20.00	7.25	7.00	1.24	-	2	2
Opening 2		-	-	20.00	29.75	9.75	-	-	8.00	2	2
Segment 3		-	-	29.75	33.00	3.25	3.00	2.77	-	2	2
Level 2											
Line 1		5	0.00	0.00	33.00	33.00	13.50	-	9.00	-	-
Wall 1-1	Seg	5	0.00	0.00	33.00	33.00	13.50	-	-	2	2
Segment 1		-	-	0.00	3.00	3.00	2.75	3.00	-	2	2
Opening 1		-	-	3.00	12.75	9.75	-	-	8.00	2	2
Segment 2		-	-	12.75	20.00	7.25	7.00	1.24	-	2	2
Opening 2		-	-	20.00	29.75	9.75	-	-	8.00	2	2
Segment 3		-	-	29.75	33.00	3.25	3.00	2.77	-	2	2
Level 1											
Line 1		1	0.00	0.00	33.00	33.00	15.00	-	14.75	-	-
Wall 1-1	Seg	1	0.00	0.00	7.50	7.50	7.25	1.97	-	2	2
Wall 1-2	Prf		0.00	7.50	25.50	18.00	0.00	-	-	2	2
Segment 1		-	-	7.50	4.00	3.50	-3.50	-4.21	-	-	-
Opening 1		-	-	4.00	11.00	7.00	7.00	-	11.25	-	-
Segment 2		-	-	11.00	13.00	2.00	2.00	7.38	-	-	-
Opening 2		-	-	13.00	29.00	16.00	16.00	-	11.25	-	-
Segment 3		-	-	29.00	25.50	3.50	-3.50	-4.21	-	-	-
Wall 1-3	Seg	1	0.00	25.50	33.00	7.50	7.25	1.97	-	2	2
Line 2											
Level 4											
Line 2		2	38.25	0.00	33.00	33.00	16.50	-	9.00	-	-
Wall 2-1	Prf	2	38.25	0.00	18.75	18.75	16.50	-	-	2	2
Segment 1		-	-	0.00	11.75	11.75	11.75	0.77	-	-	-
Opening 1		-	-	11.75	14.00	2.25	2.25	-	1.50	-	-
Segment 2		-	-	14.00	18.75	4.75	4.75	1.89	-	-	-
Wall 2-2	NSW		38.25	18.75	33.00	14.25	0.00	-	-	2	2
Segment 1		-	-	18.75	18.75	0.00	-	-	-	2	2
Opening 1		-	-	18.75	21.00	2.25	-	-	1.50	2	2
Segment 2		-	-	21.00	33.00	12.00	-	-	-	2	2
Level 3											
Line 2	Seg	7	38.25	0.00	33.00	33.00	18.75	-	9.00	-	-
Wall 2-1	Seg	7	38.25	0.00	19.00	19.00	18.75	0.47	-	2	2
Level 2											
Line 2	Seg	7	38.25	0.00	33.00	33.00	18.75	-	9.00	-	-
Wall 2-1	Seg	7	38.25	0.00	19.00	19.00	18.75	0.47	-	2	2
Level 1											
Line 2	Seg	8	38.25	0.00	33.00	33.00	18.75	-	14.75	-	-
Wall 2-1	Seg	8	38.25	0.00	19.00	19.00	18.75	0.78	-	2	2
Line 3											
Level 3											
Line 3		7	47.00	0.00	33.00	33.00	14.00	-	9.00	-	-
Wall 3-1	Seg	7	47.00	0.00	19.00	19.00	14.00	-	-	2	2
Segment 1		-	-	0.00	2.00	2.00	-	4.50	-	2	2
Opening 1		-	-	2.00	5.00	3.00	-	-	7.00	2	2
Segment 2		-	-	5.00	19.00	14.00	13.75	0.64	-	2	2
Level 2											
Line 3		7	47.00	0.00	33.00	33.00	14.00	-	9.00	-	-
Wall 3-1	Seg	7	47.00	0.00	19.00	19.00	14.00	-	-	2	2
Segment 1		-	-	0.00	2.00	2.00	-	4.50	-	2	2
Opening 1		-	-	2.00	5.00	3.00	-	-	7.00	2	2
Segment 2		-	-	5.00	19.00	14.00	13.75	0.64	-	2	2
Level 1											
Line 3		8	47.00	0.00	33.00	33.00	14.00	-	14.75	-	-
Wall 3-1	Seg	8	47.00	0.00	19.00	19.00	14.00	-	-	2	2

WoodWorks® Shearwalls

SHEARLINE, WALL and OPENING DIMENSIONS (continued)

Segment 1	-	-	0.00	2.00	2.00	-	7.38	-	2	2	
Opening 1	-	-	2.00	5.00	3.00	-	-	7.00	2	2	
Segment 2	-	-	5.00	19.00	14.00	13.75	1.05	-	2	2	
Line 4											
Level 3											
Line 4	NSW		58.50	0.00	4.25	4.25	0.00	-	9.00	-	-
Wall 4-1	NSW		58.50	0.00	4.25	4.25	0.00	1.00	-	2	2
Level 2											
Line 4	NSW		58.50	0.00	4.25	4.25	0.00	-	9.00	-	-
Wall 4-1	NSW		58.50	0.00	4.25	4.25	0.00	1.00	-	2	2
Line 5											
Level 3											
Line 5	NSW		72.50	0.00	4.25	4.25	0.00	-	9.00	-	-
Wall 5-1	NSW		72.50	0.00	4.25	4.25	0.00	1.00	-	2	2
Level 2											
Line 5	NSW		72.50	0.00	4.25	4.25	0.00	-	9.00	-	-
Wall 5-1	NSW		72.50	0.00	4.25	4.25	0.00	1.00	-	2	2
Line 6											
Level 3											
Line 6		2	89.00	0.00	33.00	33.00	25.75	-	9.00	-	-
Wall 6-1	Prf	2	89.00	0.00	33.00	33.00	25.75	-	-	2	2
Segment 1	-	-	-	0.00	7.75	7.75	7.75	1.16	-	-	-
Opening 1	-	-	-	7.75	10.25	2.50	2.50	-	5.50	-	-
Segment 2	-	-	-	10.25	14.75	4.50	4.50	2.00	-	-	-
Opening 2	-	-	-	14.75	17.00	2.25	2.25	-	1.50	-	-
Segment 3	-	-	-	17.00	22.75	5.75	5.75	1.57	-	-	-
Opening 3	-	-	-	22.75	25.25	2.50	2.50	-	5.50	-	-
Segment 4	-	-	-	25.25	33.00	7.75	7.75	1.16	-	-	-
Level 2											
Line 6		9	89.00	0.00	33.00	33.00	25.75	-	9.00	-	-
Wall 6-1	Prf	9	89.00	0.00	33.00	33.00	25.75	-	-	2	2
Segment 1	-	-	-	0.00	7.75	7.75	7.75	1.16	-	-	-
Opening 1	-	-	-	7.75	10.25	2.50	2.50	-	5.50	-	-
Segment 2	-	-	-	10.25	14.75	4.50	4.50	2.00	-	-	-
Opening 2	-	-	-	14.75	17.00	2.25	2.25	-	1.50	-	-
Segment 3	-	-	-	17.00	22.75	5.75	5.75	1.57	-	-	-
Opening 3	-	-	-	22.75	25.25	2.50	2.50	-	5.50	-	-
Segment 4	-	-	-	25.25	33.00	7.75	7.75	1.16	-	-	-
Level 1											
Line 6		1	89.00	0.00	33.00	33.00	15.00	-	14.75	-	-
Wall 6-1	Seg	1	89.00	0.00	7.50	7.50	7.25	1.97	-	2	2
Wall 6-2	Prf		89.00	7.50	25.50	18.00	0.00	-	-	2	2
Segment 1	-	-	-	7.50	2.00	5.50	-5.50	-2.68	-	-	-
Opening 1	-	-	-	2.00	31.00	29.00	29.00	-	8.00	-	-
Segment 2	-	-	-	31.00	25.50	5.50	-5.50	-2.68	-	-	-
Wall 6-3	Seg	1	89.00	25.50	33.00	7.50	7.25	1.97	-	2	2
East-west Shearlines	Type	Wall Group	Location Y [ft]	Extent [ft] Start	Extent [ft] End	Length [ft]	FHS [ft]	Aspect Ratio	Height [ft]	Studs W	Studs E
Line A											
Level 4											
Line A		4	0.00	0.00	38.25	38.25	12.25	-	9.00	-	-
Wall A-1	NSW		0.00	0.00	12.50	12.50	0.00	-	-	2	2
Segment 1	-	-	-	0.00	2.00	2.00	-	-	-	2	2
Opening 1	-	-	-	2.00	12.50	10.50	-	-	6.00	2	2
Segment 2	-	-	-	12.50	12.50	0.00	-	-	-	2	2
Wall A-2	Prf	4	0.00	12.50	38.25	25.75	12.25	-	-	2	2
Segment 1	-	-	-	12.50	18.50	6.00	6.00	1.50	-	-	-
Opening 1	-	-	-	18.50	23.25	4.75	4.75	-	4.50	-	-
Segment 2	-	-	-	23.25	29.50	6.25	6.25	1.44	-	-	-
Opening 2	-	-	-	29.50	35.75	6.25	6.25	-	6.50	-	-
Segment 3	-	-	-	35.75	38.25	2.50	2.50	3.60	-	-	-
Level 3											
Line A		4	0.00	0.00	89.00	89.00	36.96	-	9.00	-	-
Wall A-1	NSW		0.00	0.00	11.50	11.50	0.00	-	-	2	2
Segment 1	-	-	-	0.00	2.00	2.00	-	-	-	2	2
Opening 1	-	-	-	2.00	12.50	10.50	-	-	6.00	2	2
Segment 2	-	-	-	12.50	11.50	1.00	-	-	-	2	2
Wall A-2	Prf	4	0.00	11.50	58.50	47.00	27.74	-	-	2	2
Segment 1	-	-	-	11.50	18.50	7.00	7.00	1.29	-	-	-
Opening 1	-	-	-	18.50	23.25	4.75	4.75	-	4.50	-	-
Segment 2	-	-	-	23.25	31.50	8.25	8.25	1.09	-	-	-
Opening 2	-	-	-	31.50	34.00	2.50	2.50	-	4.50	-	-
Segment 3	-	-	-	34.00	41.25	7.25	7.25	1.24	-	-	-

WoodWorks® Shearwalls

SHEARLINE, WALL and OPENING DIMENSIONS (continued)

Opening 3	-	-	41.25	44.25	3.00	3.00	-	6.50	-	-	
Segment 4	-	-	44.25	48.25	4.00	3.56	2.25	-	-	-	
Opening 4	-	-	48.25	51.00	2.75	2.75	-	6.50	-	-	
Segment 5	-	-	51.00	53.00	2.00	2.00	4.50	-	-	-	
Opening 5	-	-	53.00	55.75	2.75	2.75	-	6.50	-	-	
Segment 6	-	-	55.75	58.50	2.75	1.68	3.27	-	-	-	
Wall A-3	Prf	4	0.00	72.50	89.00	16.50	9.22	-	-	2 2	
Segment 1	-	-	72.50	77.00	4.50	4.50	2.00	-	-	-	
Opening 1	-	-	77.00	79.75	2.75	2.75	-	6.50	-	-	
Segment 2	-	-	79.75	82.75	3.00	2.00	3.00	-	-	-	
Opening 2	-	-	82.75	85.50	2.75	2.75	-	6.50	-	-	
Segment 3	-	-	85.50	89.00	3.50	2.72	2.57	-	-	-	
Level 2											
Line A		3,4	0.00	0.00	89.00	89.00	36.96	-	9.00	-	-
Wall A-1	NSW		0.00	0.00	11.50	11.50	0.00	-	-	2 2	
Segment 1	-	-	-	0.00	2.00	2.00	-	-	-	2 2	
Opening 1	-	-	-	2.00	12.50	10.50	-	-	6.00	2 2	
Segment 2	-	-	-	12.50	11.50	1.00	-	-	-	2 2	
Wall A-2	Prf	3	0.00	11.50	58.50	47.00	27.74	-	-	2 2	
Segment 1	-	-	-	11.50	18.50	7.00	7.00	1.29	-	-	-
Opening 1	-	-	-	18.50	23.25	4.75	4.75	-	4.50	-	-
Segment 2	-	-	-	23.25	31.50	8.25	8.25	1.09	-	-	-
Opening 2	-	-	-	31.50	34.00	2.50	2.50	-	4.50	-	-
Segment 3	-	-	-	34.00	41.25	7.25	7.25	1.24	-	-	-
Opening 3	-	-	-	41.25	44.25	3.00	3.00	-	6.50	-	-
Segment 4	-	-	-	44.25	48.25	4.00	3.56	2.25	-	-	-
Opening 4	-	-	-	48.25	51.00	2.75	2.75	-	5.50	-	-
Segment 5	-	-	-	51.00	53.00	2.00	2.00	4.50	-	-	-
Opening 5	-	-	-	53.00	55.75	2.75	2.75	-	6.50	-	-
Segment 6	-	-	-	55.75	58.50	2.75	1.68	3.27	-	-	-
Wall A-3	Prf	4	0.00	72.50	89.00	16.50	9.22	-	-	2 2	
Segment 1	-	-	-	72.50	77.00	4.50	4.50	2.00	-	-	-
Opening 1	-	-	-	77.00	79.75	2.75	2.75	-	6.50	-	-
Segment 2	-	-	-	79.75	82.75	3.00	2.00	3.00	-	-	-
Opening 2	-	-	-	82.75	85.50	2.75	2.75	-	6.50	-	-
Segment 3	-	-	-	85.50	89.00	3.50	2.72	2.57	-	-	-
Level 1											
Line A		1,2	0.00	0.00	89.00	89.00	34.25	-	14.75	-	-
Wall A-1	Prf		0.00	0.00	16.25	16.25	0.00	-	-	2 2	
Segment 1	-	-	-	0.00	2.00	2.00	2.00	7.38	-	-	-
Opening 1	-	-	-	2.00	12.50	10.50	10.50	-	8.50	-	-
Segment 2	-	-	-	12.50	16.25	3.75	3.75	3.93	-	-	-
Wall A-2	Seg	1	0.00	16.25	38.00	21.75	21.50	0.68	-	2 2	
Wall A-3	Prf	2	0.00	38.00	89.00	51.00	12.50	-	-	2 2	
Segment 1	-	-	-	38.00	41.25	3.25	3.25	4.54	-	-	-
Opening 1	-	-	-	41.25	44.25	3.00	3.00	-	8.00	-	-
Segment 2	-	-	-	44.25	48.25	4.00	4.00	3.69	-	-	-
Opening 2	-	-	-	48.25	51.25	3.00	3.00	-	4.00	-	-
Segment 3	-	-	-	51.25	63.75	12.50	12.50	1.18	-	-	-
Opening 3	-	-	-	63.75	66.75	3.00	3.00	-	3.50	-	-
Segment 4	-	-	-	66.75	70.00	3.25	3.25	4.54	-	-	-
Opening 4	-	-	-	70.00	73.00	3.00	3.00	-	3.50	-	-
Segment 5	-	-	-	73.00	77.00	4.00	4.00	3.69	-	-	-
Opening 5	-	-	-	77.00	80.00	3.00	3.00	-	3.50	-	-
Segment 6	-	-	-	80.00	83.00	3.00	3.00	4.92	-	-	-
Opening 6	-	-	-	83.00	86.00	3.00	3.00	-	3.50	-	-
Segment 7	-	-	-	86.00	89.00	3.00	3.00	4.92	-	-	-
Line B											
Level 3											
Line B			4.25	58.50	72.50	14.00	0.00	-	9.00	-	-
Wall B-1	NSW		4.25	58.50	72.50	14.00	0.00	-	-	2 2	
Segment 1	-	-	-	58.50	60.50	2.00	-	-	-	2 2	
Opening 1	-	-	-	60.50	70.50	10.00	-	-	8.00	2 2	
Segment 2	-	-	-	70.50	72.50	2.00	-	-	-	2 2	
Level 2											
Line B			4.25	58.50	72.50	14.00	0.00	-	9.00	-	-
Wall B-1	NSW		4.25	58.50	72.50	14.00	0.00	-	-	2 2	
Segment 1	-	-	-	58.50	60.50	2.00	-	-	-	2 2	
Opening 1	-	-	-	60.50	70.50	10.00	-	-	8.00	2 2	
Segment 2	-	-	-	70.50	72.50	2.00	-	-	-	2 2	
Line C											
Level 4											
Line C		2	33.00	0.00	38.25	38.25	19.50	-	9.00	-	-

WoodWorks® Shearwalls

SHEARLINE, WALL and OPENING DIMENSIONS (continued)

Wall C-1	Prf	2	33.00	0.00	38.25	38.25	19.50	-	-	2	2
Segment 1	-	-	-	0.00	2.00	2.00	2.00	4.50	-	-	-
Opening 1	-	-	-	2.00	4.50	2.50	2.50	-	5.75	-	-
Segment 2	-	-	-	4.50	11.25	6.75	6.75	1.33	-	-	-
Opening 2	-	-	-	11.25	13.75	2.50	2.50	-	5.75	-	-
Segment 3	-	-	-	13.75	16.25	2.50	2.50	3.60	-	-	-
Opening 3	-	-	-	16.25	18.75	2.50	2.50	-	4.50	-	-
Segment 4	-	-	-	18.75	29.50	10.75	10.75	0.84	-	-	-
Opening 4	-	-	-	29.50	35.25	5.75	5.75	-	5.75	-	-
Segment 5	-	-	-	35.25	38.25	3.00	2.00	3.00	-	-	-
Level 3											
Line C		2	33.00	0.00	89.00	89.00	65.75	-	9.00	-	-
Wall C-1	Prf	2	33.00	0.00	89.00	89.00	65.75	-	-	2	2
Segment 1	-	-	-	0.00	2.00	2.00	2.00	4.50	-	-	-
Opening 1	-	-	-	2.00	4.50	2.50	2.50	-	6.50	-	-
Segment 2	-	-	-	4.50	11.25	6.75	6.75	1.33	-	-	-
Opening 2	-	-	-	11.25	13.75	2.50	2.50	-	6.50	-	-
Segment 3	-	-	-	13.75	23.25	9.50	9.50	0.95	-	-	-
Opening 3	-	-	-	23.25	25.75	2.50	2.50	-	4.50	-	-
Segment 4	-	-	-	25.75	57.50	31.75	31.75	0.28	-	-	-
Opening 4	-	-	-	57.50	63.25	5.75	5.75	-	4.50	-	-
Segment 5	-	-	-	63.25	70.00	6.75	6.75	1.33	-	-	-
Opening 5	-	-	-	70.00	72.25	2.25	2.25	-	1.50	-	-
Segment 6	-	-	-	72.25	77.50	5.25	5.25	1.71	-	-	-
Opening 6	-	-	-	77.50	83.25	5.75	5.75	-	5.75	-	-
Segment 7	-	-	-	83.25	89.00	5.75	5.75	1.57	-	-	-
Level 2											
Line C		2	33.00	0.00	89.00	89.00	63.31	-	9.00	-	-
Wall C-1	Prf	2	33.00	0.00	89.00	89.00	63.31	-	-	2	2
Segment 1	-	-	-	0.00	2.00	2.00	2.00	4.50	-	-	-
Opening 1	-	-	-	2.00	4.50	2.50	2.50	-	6.50	-	-
Segment 2	-	-	-	4.50	12.50	8.00	8.00	1.12	-	-	-
Opening 2	-	-	-	12.50	14.75	2.25	2.25	-	1.50	-	-
Segment 3	-	-	-	14.75	18.75	4.00	3.56	2.25	-	-	-
Opening 3	-	-	-	18.75	21.00	2.25	2.25	-	1.50	-	-
Segment 4	-	-	-	21.00	31.25	10.25	10.25	0.88	-	-	-
Opening 4	-	-	-	31.25	33.75	2.50	2.50	-	4.50	-	-
Segment 5	-	-	-	33.75	57.50	23.75	23.75	0.38	-	-	-
Opening 5	-	-	-	57.50	63.25	5.75	5.75	-	4.50	-	-
Segment 6	-	-	-	63.25	70.00	6.75	6.75	1.33	-	-	-
Opening 6	-	-	-	70.00	72.25	2.25	2.25	-	1.50	-	-
Segment 7	-	-	-	72.25	77.50	5.25	5.25	1.71	-	-	-
Opening 7	-	-	-	77.50	83.25	5.75	5.75	-	5.75	-	-
Segment 8	-	-	-	83.25	89.00	5.75	5.75	1.57	-	-	-
Level 1											
Line C		2,1	33.00	0.00	89.00	89.00	66.70	-	14.75	-	-
Wall C-1	Seg	1	33.00	0.00	29.00	29.00	28.75	0.51	-	2	2
Wall C-2	Prf	2	33.00	29.00	89.00	60.00	37.70	-	-	2	2
Segment 1	-	-	-	29.00	32.75	3.75	3.75	3.93	-	-	-
Opening 1	-	-	-	32.75	35.75	3.00	3.00	-	8.00	-	-
Segment 2	-	-	-	35.75	48.25	12.50	12.50	1.18	-	-	-
Opening 2	-	-	-	48.25	51.25	3.00	3.00	-	8.00	-	-
Segment 3	-	-	-	51.25	52.75	1.50	1.50	9.83	-	-	-
Opening 3	-	-	-	52.75	56.25	3.50	3.50	-	8.00	-	-
Segment 4	-	-	-	56.25	71.75	15.50	15.50	0.95	-	-	-
Opening 4	-	-	-	71.75	74.50	2.75	2.75	-	3.50	-	-
Segment 5	-	-	-	74.50	79.25	4.75	3.06	3.11	-	-	-
Opening 5	-	-	-	79.25	82.00	2.75	2.75	-	3.50	-	-
Segment 6	-	-	-	82.00	89.00	7.00	6.64	2.11	-	-	-

Legend:

Type – Seg: Segmented, Prf: Perforated, FT: FTAO (force transfer around openings), NSW: Non-shearwall, NW: Non-wood/Proprietary, ND: Not designed

Location – Position in structure perpendicular to wall

Length – Shear line: Distance between exterior perpendicular walls defining the shear line extent

Wall, segment, or opening: End-to-end length of the element

FHS – Depending on element, shows different definitions of full-height sheathing length (FHS):

Shear lines with multiple walls, segmented walls, or FTAO walls: Total shear-resisting FHS

Individual wall segments or walls without openings: Distance between hold-downs beff

Perforated walls: Sum of factored segment lengths bi defined in SDPWS 4.3.5.6

Aspect Ratio – Ratio of wall height to segment length (h/b); for FTAO walls, the aspect ratio of the central pier

Wall Group – Wall design group defined in Sheathing and Framing Materials tables, where it shows associated Standard Wall

WoodWorks® Shearwalls

*Studs: Number of end studs at the south and north or west and east ends of a wall segment or a perforated or FTAO wall.
If two wall group numbers listed, they are for rigid diaphragm and flexible diaphragm design.*

WoodWorks® Shearwalls

Loads

WIND SHEAR LOADS (as entered or generated)

Level 4 Block	F	Element	Load Case	Wnd Dir	Surf Dir	Prof	Location [ft]		Magnitude [lbs,plf,psf]		Trib Ht [ft]
							Start	End	Start	End	
Block 1	W	Wall	1	W->E	Wind	Line	0.00	33.00	76.7		
Block 1	W	R Gable	1	W->E	Wind	Line	0.00	33.00	6.0	0.0	
Block 1	W	R Gable	2	W->E	Wind	Line	0.00	33.00	4.5	0.0	
Block 1	W	Wall	2	W->E	Wind	Line	0.00	33.00	57.6		
Block 1	E	R Gable	1	W->E	Lee	Line	0.00	33.00	3.5	0.0	
Block 1	E	Wall	2	W->E	Lee	Line	0.00	33.00	34.2		
Block 1	E	Wall	1	W->E	Lee	Line	0.00	33.00	45.5		
Block 1	E	R Gable	2	W->E	Lee	Line	0.00	33.00	2.6	0.0	
Block 1	W	Wall	1	E->W	Lee	Line	0.00	33.00	45.5		
Block 1	W	Wall	2	E->W	Lee	Line	0.00	33.00	34.2		
Block 1	W	R Gable	1	E->W	Lee	Line	0.00	33.00	3.5	0.0	
Block 1	W	R Gable	2	E->W	Lee	Line	0.00	33.00	2.6	0.0	
Block 1	E	Wall	2	E->W	Wind	Line	0.00	33.00	57.6		
Block 1	E	R Gable	2	E->W	Wind	Line	0.00	33.00	4.5	0.0	
Block 1	E	R Gable	1	E->W	Wind	Line	0.00	33.00	6.0	0.0	
Block 1	E	Wall	1	E->W	Wind	Line	0.00	33.00	76.7		
Block 1	S	Wall	2	S->N	Wind	Line	0.00	38.25	57.6		
Block 1	S	Attic Wall	1	S->N	Wind	Line	0.00	38.25	6.0		
Block 1	S	Wall	1	S->N	Wind	Line	0.00	38.25	76.7		
Block 1	S	Attic Wall	2	S->N	Wind	Line	0.00	38.25	4.5		
Block 1	N	Roof	1	S->N	Lee	Line	0.00	38.25	0.0		
Block 1	N	Roof	2	S->N	Lee	Line	0.00	38.25	0.0		
Block 1	N	Wall	1	S->N	Lee	Line	0.00	38.25	48.6		
Block 1	N	Wall	2	S->N	Lee	Line	0.00	38.25	36.4		
Block 1	S	Wall	2	N->S	Lee	Line	0.00	38.25	36.5		
Block 1	S	Wall	1	N->S	Lee	Line	0.00	38.25	48.6		
Block 1	S	Attic Wall	1	N->S	Lee	Line	0.00	38.25	4.5		
Block 1	S	Attic Wall	2	N->S	Lee	Line	0.00	38.25	3.4		
Block 1	N	Wall	1	N->S	Wind	Line	0.00	38.25	76.7		
Block 1	N	Roof	1	N->S	Wind	Line	0.00	38.25	0.0		
Block 1	N	Roof	2	N->S	Wind	Line	0.00	38.25	0.0		
Block 1	N	Wall	2	N->S	Wind	Line	0.00	38.25	57.6		
Level 3 Block	F	Element	Load Case	Wnd Dir	Surf Dir	Prof	Location [ft]		Magnitude [lbs,plf,psf]		Trib Ht [ft]
Block 1	W	Wall	2	W->E	Wind	Line	0.00	4.25	77.8		
Block 1	W	Wall	1	W->E	Wind	Line	0.00	33.00	103.7		
Block 1	W	Wall	2	W->E	Wind	Line	0.00	33.00	56.0		
Block 1	W	Wall	1	W->E	Wind	Line	0.00	4.25	103.7		
Block 1	W	Wall	2	W->E	Wind	Line	0.00	33.00	77.8		
Block 1	W	Wall	1	W->E	Wind	Line	0.00	33.00	74.6		
Block 1	E	Wall	2	W->E	Lee	Line	0.00	4.25	49.3		
Block 1	E	Wall	1	W->E	Lee	Line	0.00	4.25	65.8		
Block 1	E	Wall	2	W->E	Lee	Line	0.00	33.00	34.2		
Block 1	E	Wall	1	W->E	Lee	Line	0.00	33.00	65.8		
Block 1	E	Wall	2	W->E	Lee	Line	0.00	33.00	49.3		
Block 1	E	Wall	1	W->E	Lee	Line	0.00	33.00	45.5		
Block 1	W	Wall	2	E->W	Lee	Line	0.00	33.00	49.3		
Block 1	W	Wall	1	E->W	Lee	Line	0.00	33.00	45.5		
Block 1	W	Wall	2	E->W	Lee	Line	0.00	33.00	34.2		
Block 1	W	Wall	2	E->W	Lee	Line	0.00	4.25	49.3		
Block 1	W	Wall	1	E->W	Lee	Line	0.00	4.25	65.8		
Block 1	W	Wall	1	E->W	Lee	Line	0.00	33.00	65.8		
Block 1	E	Wall	1	E->W	Wind	Line	0.00	33.00	74.6		
Block 1	E	Wall	2	E->W	Wind	Line	0.00	33.00	56.0		
Block 1	E	Wall	1	E->W	Wind	Line	0.00	4.25	103.7		
Block 1	E	Wall	1	E->W	Wind	Line	0.00	33.00	103.7		
Block 1	E	Wall	2	E->W	Wind	Line	0.00	4.25	77.8		
Block 1	E	Wall	2	E->W	Wind	Line	0.00	33.00	77.8		
Block 1	S	Wall	2	S->N	Wind	Line	0.00	38.25	56.0		
Block 1	S	Wall	1	S->N	Wind	Line	0.00	58.50	103.7		
Block 1	S	Wall	1	S->N	Wind	Line	0.00	38.25	74.6		
Block 1	S	Wall	2	S->N	Wind	Line	0.00	58.50	77.8		
Block 1	S	Wall	2	S->N	Wind	Line	58.50	72.50	77.8		
Block 1	S	Wall	1	S->N	Wind	Line	58.50	72.50	103.7		
Block 1	S	Wall	1	S->N	Wind	Line	72.50	89.00	103.7		
Block 1	S	Wall	2	S->N	Wind	Line	72.50	89.00	77.8		
Block 1	N	Wall	2	S->N	Lee	Line	0.00	89.00	52.6		

WoodWorks® Shearwalls

WIND SHEAR LOADS (as entered or generated) (continued)

Block 1	N	Wall	1	S->N	Lee	Line	0.00	89.00	70.2		
Block 1	N	Wall	2	S->N	Lee	Line	0.00	38.25	36.4		
Block 1	N	Wall	1	S->N	Lee	Line	0.00	38.25	48.6		
Block 1	S	Wall	1	N->S	Lee	Line	0.00	58.50	70.3		
Block 1	S	Wall	2	N->S	Lee	Line	0.00	58.50	52.7		
Block 1	S	Wall	1	N->S	Lee	Line	0.00	38.25	48.6		
Block 1	S	Wall	2	N->S	Lee	Line	0.00	38.25	36.5		
Block 1	S	Wall	2	N->S	Lee	Line	58.50	72.50	52.7		
Block 1	S	Wall	1	N->S	Lee	Line	58.50	72.50	70.3		
Block 1	S	Wall	2	N->S	Lee	Line	72.50	89.00	52.7		
Block 1	S	Wall	1	N->S	Lee	Line	72.50	89.00	70.3		
Block 1	N	Wall	2	N->S	Wind	Line	0.00	38.25	56.0		
Block 1	N	Wall	1	N->S	Wind	Line	0.00	89.00	103.7		
Block 1	N	Wall	1	N->S	Wind	Line	0.00	38.25	74.6		
Block 1	N	Wall	2	N->S	Wind	Line	0.00	89.00	77.8		
Block 2	E	R Gable	2	W->E	Lee	Line	0.00	33.00	2.1	0.0	
Block 2	E	R Gable	1	W->E	Lee	Line	0.00	33.00	2.7	0.0	
Block 2	E	R Gable	1	E->W	Wind	Line	0.00	33.00	5.6	0.0	
Block 2	E	R Gable	2	E->W	Wind	Line	0.00	33.00	4.2	0.0	
Block 2	S	Attic Wall	2	S->N	Wind	Line	38.25	89.00	4.2		
Block 2	S	Attic Wall	1	S->N	Wind	Line	38.25	89.00	5.6		
Block 2	N	Roof	1	S->N	Lee	Line	38.25	89.00	0.0		
Block 2	N	Roof	2	S->N	Lee	Line	38.25	89.00	0.0		
Block 2	S	Attic Wall	1	N->S	Lee	Line	38.25	89.00	4.2		
Block 2	S	Attic Wall	2	N->S	Lee	Line	38.25	89.00	3.1		
Block 2	N	Roof	2	N->S	Wind	Line	38.25	89.00	0.0		
Block 2	N	Roof	1	N->S	Wind	Line	38.25	89.00	0.0		
Level 2	F	Element	Load Case	Wnd Dir	Surf Dir	Prof	Location [ft]	Magnitude [lbs,plf,psf]	Trib Ht [ft]		
Block							Start End	Start End			
Block 1	W	Wall	2	W->E	Wind	Line	0.00 33.00	51.6			
Block 1	W	Wall	1	W->E	Wind	Line	0.00 4.25	68.7			
Block 1	W	Wall	1	W->E	Wind	Line	0.00 33.00	94.2			
Block 1	W	Wall	1	W->E	Wind	Line	0.00 4.25	94.2			
Block 1	W	Wall	2	W->E	Wind	Line	0.00 33.00	70.7			
Block 1	W	Wall	2	W->E	Wind	Line	0.00 4.25	70.7			
Block 1	W	Wall	2	W->E	Wind	Line	0.00 4.25	51.6			
Block 1	W	Wall	1	W->E	Wind	Line	0.00 33.00	68.7			
Block 1	E	Wall	2	W->E	Lee	Line	0.00 4.25	34.2			
Block 1	E	Wall	2	W->E	Lee	Line	0.00 33.00	34.2			
Block 1	E	Wall	1	W->E	Lee	Line	0.00 4.25	45.5			
Block 1	E	Wall	2	W->E	Lee	Line	0.00 33.00	49.3			
Block 1	E	Wall	1	W->E	Lee	Line	0.00 4.25	65.8			
Block 1	E	Wall	1	W->E	Lee	Line	0.00 33.00	45.5			
Block 1	E	Wall	1	W->E	Lee	Line	0.00 33.00	65.8			
Block 1	E	Wall	2	W->E	Lee	Line	0.00 4.25	49.3			
Block 1	W	Wall	1	E->W	Lee	Line	0.00 4.25	65.8			
Block 1	W	Wall	2	E->W	Lee	Line	0.00 4.25	49.3			
Block 1	W	Wall	2	E->W	Lee	Line	0.00 33.00	34.2			
Block 1	W	Wall	1	E->W	Lee	Line	0.00 33.00	45.5			
Block 1	W	Wall	1	E->W	Lee	Line	0.00 4.25	45.5			
Block 1	W	Wall	2	E->W	Lee	Line	0.00 33.00	49.3			
Block 1	E	Wall	2	E->W	Wind	Line	0.00 33.00	51.6			
Block 1	E	Wall	2	E->W	Wind	Line	0.00 4.25	51.6			
Block 1	E	Wall	1	E->W	Wind	Line	0.00 33.00	68.7			
Block 1	E	Wall	2	E->W	Wind	Line	0.00 4.25	70.7			
Block 1	E	Wall	1	E->W	Wind	Line	0.00 4.25	68.7			
Block 1	E	Wall	1	E->W	Wind	Line	0.00 33.00	94.2			
Block 1	E	Wall	1	E->W	Wind	Line	0.00 4.25	94.2			
Block 1	E	Wall	2	E->W	Wind	Line	0.00 33.00	70.7			
Block 1	S	Wall	1	S->N	Wind	Line	0.00 58.50	94.2			
Block 1	S	Wall	1	S->N	Wind	Line	0.00 58.50	68.7			
Block 1	S	Wall	2	S->N	Wind	Line	0.00 58.50	70.7			
Block 1	S	Wall	2	S->N	Wind	Line	0.00 58.50	51.6			
Block 1	S	Wall	1	S->N	Wind	Line	58.50 72.50	94.2			
Block 1	S	Wall	2	S->N	Wind	Line	58.50 72.50	51.6			
Block 1	S	Wall	1	S->N	Wind	Line	58.50 72.50	68.7			
Block 1	S	Wall	2	S->N	Wind	Line	58.50 72.50	70.7			
Block 1	S	Wall	2	S->N	Wind	Line	72.50 89.00	70.7			
Block 1	S	Wall	2	S->N	Wind	Line	72.50 89.00	51.6			
Block 1	S	Wall	1	S->N	Wind	Line	72.50 89.00	68.7			

WoodWorks® Shearwalls

WIND SHEAR LOADS (as entered or generated) (continued)

Block 1	S	Wall	1	S->N	Wind	Line	72.50	89.00	94.2		
Block 1	N	Wall	1	S->N	Lee	Line	0.00	89.00	70.2		
Block 1	N	Wall	2	S->N	Lee	Line	0.00	89.00	36.4		
Block 1	N	Wall	1	S->N	Lee	Line	0.00	89.00	48.6		
Block 1	N	Wall	2	S->N	Lee	Line	0.00	89.00	52.6		
Block 1	S	Wall	2	N->S	Lee	Line	0.00	58.50	52.7		
Block 1	S	Wall	2	N->S	Lee	Line	0.00	58.50	36.5		
Block 1	S	Wall	1	N->S	Lee	Line	0.00	58.50	48.6		
Block 1	S	Wall	1	N->S	Lee	Line	0.00	58.50	70.3		
Block 1	S	Wall	2	N->S	Lee	Line	58.50	72.50	36.5		
Block 1	S	Wall	2	N->S	Lee	Line	58.50	72.50	52.7		
Block 1	S	Wall	1	N->S	Lee	Line	58.50	72.50	70.3		
Block 1	S	Wall	1	N->S	Lee	Line	58.50	72.50	48.6		
Block 1	S	Wall	1	N->S	Lee	Line	72.50	89.00	48.6		
Block 1	S	Wall	2	N->S	Lee	Line	72.50	89.00	52.7		
Block 1	S	Wall	2	N->S	Lee	Line	72.50	89.00	36.5		
Block 1	S	Wall	1	N->S	Lee	Line	72.50	89.00	70.3		
Block 1	N	Wall	2	N->S	Wind	Line	0.00	89.00	70.7		
Block 1	N	Wall	1	N->S	Wind	Line	0.00	89.00	94.2		
Block 1	N	Wall	1	N->S	Wind	Line	0.00	89.00	68.7		
Block 1	N	Wall	2	N->S	Wind	Line	0.00	89.00	51.6		
Level 1											
Block	F	Element	Load Case	Wnd Dir	Surf Dir	Prof	Location [ft]		Magnitude [lbs,plf,psf]		Trib Ht [ft]
							Start	End	Start	End	
Block 1	W	Wall	1	W->E	Wind	Line	0.00	4.25	61.2		
Block 1	W	Wall	2	W->E	Wind	Line	0.00	33.00	45.9		
Block 1	W	Wall	2	W->E	Wind	Line	0.00	4.25	45.9		
Block 1	W	Wall	1	W->E	Wind	Line	0.00	33.00	61.2		
Block 1	W	Wall	2	W->E	Wind	Line	0.00	33.00	87.6		
Block 1	W	Wall	1	W->E	Wind	Line	0.00	33.00	116.8		
Block 1	E	Wall	2	W->E	Lee	Line	0.00	33.00	71.2		
Block 1	E	Wall	2	W->E	Lee	Line	0.00	4.25	34.2		
Block 1	E	Wall	1	W->E	Lee	Line	0.00	33.00	45.5		
Block 1	E	Wall	1	W->E	Lee	Line	0.00	4.25	45.5		
Block 1	E	Wall	1	W->E	Lee	Line	0.00	33.00	94.9		
Block 1	E	Wall	2	W->E	Lee	Line	0.00	33.00	34.2		
Block 1	W	Wall	2	E->W	Lee	Line	0.00	4.25	34.2		
Block 1	W	Wall	2	E->W	Lee	Line	0.00	33.00	34.2		
Block 1	W	Wall	2	E->W	Lee	Line	0.00	33.00	71.2		
Block 1	W	Wall	1	E->W	Lee	Line	0.00	33.00	45.5		
Block 1	W	Wall	1	E->W	Lee	Line	0.00	33.00	94.9		
Block 1	W	Wall	1	E->W	Lee	Line	0.00	4.25	45.5		
Block 1	E	Wall	2	E->W	Wind	Line	0.00	33.00	87.6		
Block 1	E	Wall	1	E->W	Wind	Line	0.00	4.25	61.2		
Block 1	E	Wall	1	E->W	Wind	Line	0.00	33.00	61.2		
Block 1	E	Wall	2	E->W	Wind	Line	0.00	4.25	45.9		
Block 1	E	Wall	2	E->W	Wind	Line	0.00	33.00	45.9		
Block 1	E	Wall	1	E->W	Wind	Line	0.00	33.00	116.8		
Block 1	S	Wall	2	S->N	Wind	Line	0.00	89.00	87.6		
Block 1	S	Wall	1	S->N	Wind	Line	0.00	58.50	61.2		
Block 1	S	Wall	1	S->N	Wind	Line	0.00	89.00	116.8		
Block 1	S	Wall	2	S->N	Wind	Line	0.00	58.50	45.9		
Block 1	S	Wall	2	S->N	Wind	Line	58.50	72.50	45.9		
Block 1	S	Wall	1	S->N	Wind	Line	58.50	72.50	61.2		
Block 1	S	Wall	1	S->N	Wind	Line	72.50	89.00	61.2		
Block 1	S	Wall	2	S->N	Wind	Line	72.50	89.00	45.9		
Block 1	N	Wall	1	S->N	Lee	Line	0.00	89.00	101.2		
Block 1	N	Wall	2	S->N	Lee	Line	0.00	89.00	36.4		
Block 1	N	Wall	2	S->N	Lee	Line	0.00	89.00	75.9		
Block 1	N	Wall	1	S->N	Lee	Line	0.00	89.00	48.6		
Block 1	S	Wall	2	N->S	Lee	Line	0.00	89.00	76.0		
Block 1	S	Wall	1	N->S	Lee	Line	0.00	89.00	101.3		
Block 1	S	Wall	2	N->S	Lee	Line	0.00	58.50	36.5		
Block 1	S	Wall	1	N->S	Lee	Line	0.00	58.50	48.6		
Block 1	S	Wall	1	N->S	Lee	Line	58.50	72.50	48.6		
Block 1	S	Wall	2	N->S	Lee	Line	58.50	72.50	36.5		
Block 1	S	Wall	1	N->S	Lee	Line	72.50	89.00	48.6		
Block 1	S	Wall	2	N->S	Lee	Line	72.50	89.00	36.5		
Block 1	N	Wall	1	N->S	Wind	Line	0.00	89.00	61.2		
Block 1	N	Wall	2	N->S	Wind	Line	0.00	89.00	87.6		
Block 1	N	Wall	1	N->S	Wind	Line	0.00	89.00	116.8		
Block 1	N	Wall	2	N->S	Wind	Line	0.00	89.00	45.9		

WoodWorks® Shearwalls

Legend:

Block - Block used in load generation

Accum. = loads from one block combined with another

Manual = user-entered loads (so no block)

F - Building face (north, south, east or west)

Element - Building surface on which loads generated or entered

Load Case - One of the following:

ASCE 7 All Heights: Case 1 or 2 from Fig 27.3-8 or minimum loads from 27.1.5

ASCE 7 Low-rise: Reference corner and Case A or B from Fig 28.3-1 or minimum loads from 28.3.4

Wind Dir - Direction of wind for loads with positive magnitude, also direction of MWFRS.

Surf Dir - Windward or leeward side of the building for loads in given direction

Prof - Profile (distribution)

Location - Start and end points on building element

Magnitude - Start = intensity of uniform and point loads or leftmost intensity of trapezoidal load, End = right intensity of trap load

Trib Ht - Tributary height of area loads only

Notes:

Windward load on the monoslope roof was not generated, to comply with ASCE 7 Figure 27.3-1, Note 7.

All loads entered by the user or generated by program are specified (unfactored) loads. The program applies a load factor of 0.60 to wind loads before distributing them to the shearlines.

WoodWorks® Shearwalls

DEAD LOADS (for hold-down calculations)

Shear Line	Level	Profile	Tributary Width [ft]	Location [ft]		Mag [lbs,psf,psi]	
				Start	End	Start	End
A	4	Line		0.00	12.50	108.0*	
A	4	Line		12.50	38.25	108.0*	
C	4	Line		0.00	38.25	108.0*	
1	4	Line		0.00	33.00	108.0*	
2	4	Line		0.00	18.75	108.0*	
2	4	Line		18.75	33.00	108.0*	
A	3	Line		0.00	11.50	108.0*	
A	3	Line		11.50	58.50	108.0*	
A	3	Line		72.50	89.00	108.0*	
B	3	Line		58.50	72.50	108.0*	
C	3	Line		0.00	89.00	108.0*	
1	3	Line		0.00	3.00	108.0*	
1	3	Line		3.00	30.00	108.0*	
1	3	Line		30.00	33.00	108.0*	
2	3	Line		0.00	19.00	90.0*	
3	3	Line		0.00	19.00	90.0*	
4	3	Line		0.00	4.25	108.0*	
5	3	Line		0.00	4.25	108.0*	
6	3	Line		0.00	33.00	108.0*	
A	2	Line		0.00	11.50	108.0*	
A	2	Line		11.50	58.50	108.0*	
A	2	Line		72.50	89.00	108.0*	
B	2	Line		58.50	72.50	108.0*	
C	2	Line		0.00	89.00	108.0*	
1	2	Line		0.00	3.00	108.0*	
1	2	Line		3.00	30.00	108.0*	
1	2	Line		30.00	33.00	108.0*	
2	2	Line		0.00	19.00	90.0*	
3	2	Line		0.00	19.00	90.0*	
4	2	Line		0.00	4.25	108.0*	
5	2	Line		0.00	4.25	108.0*	
6	2	Line		0.00	33.00	108.0*	
A	1	Line		0.00	16.25	177.0*	
A	1	Line		16.25	38.00	177.0*	
A	1	Line		38.00	89.00	177.0*	
C	1	Line		0.00	29.00	177.0*	
C	1	Line		29.00	89.00	177.0*	
1	1	Line		0.00	7.50	177.0*	
1	1	Line		7.50	25.50	177.0*	
1	1	Line		25.50	33.00	177.0*	
2	1	Line		0.00	19.00	147.5*	
3	1	Line		0.00	19.00	147.5*	
6	1	Line		0.00	7.50	177.0*	
6	1	Line		7.50	25.50	177.0*	
6	1	Line		25.50	33.00	177.0*	

WoodWorks® Shearwalls

BUILDING MASSES

Level 4				Profile	Location [ft]		Magnitude [lbs,plf,psf]		Trib Width [ft]
Force Dir	Building Element	Block	Wall Line		Start	End	Start	End	
E-W	Roof	Block 1	1	Line	0.00	33.00	363.4	363.4	
E-W	Roof	Block 1	2	Line	0.00	33.00	363.4	363.4	
E-W	L Gable	Block 1	1	Line	0.00	33.00	0.0	4.1	
E-W	R Gable	Block 1	1	Line	0.00	0.00	4.1	0.0	
E-W	L Gable	Block 1	2	Line	0.00	0.00	4.1	0.0	
E-W	R Gable	Block 1	2	Line	0.00	33.00	0.0	4.1	
N-S	Roof	Block 1	A	Line	0.00	38.25	313.5	313.5	
N-S	Roof	Block 1	C	Line	0.00	38.25	313.5	313.5	
Both	Wall 1-1	n/a	1	Line	0.00	33.00	54.0	54.0	
Both	Wall 2-1	n/a	2	Line	0.00	18.75	54.0	54.0	
Both	Wall 2-2	n/a	2	Line	18.75	33.00	54.0	54.0	
Both	Wall A-1	n/a	A	Line	0.00	12.50	54.0	54.0	
Both	Wall A-2	n/a	A	Line	12.50	38.25	54.0	54.0	
Both	Wall C-1	n/a	C	Line	0.00	38.25	54.0	54.0	
Level 3				Profile	Location [ft]		Magnitude [lbs,plf,psf]		Trib Width [ft]
Force Dir	Building Element	Block	Wall Line		Start	End	Start	End	
E-W	Roof	Block 2	2	Line	0.00	33.00	482.1	482.1	
E-W	Roof	Block 2	6	Line	0.00	33.00	482.1	482.1	
E-W	R Gable	Block 2	6	Line	0.00	33.00	0.0	4.1	
E-W	L Gable	Block 2	6	Line	0.00	0.00	4.1	0.0	
E-W	Floor F3	n/a	1	Line	0.00	4.25	438.8	438.8	
Both	Wall 1-1	n/a	1	Line	0.00	33.00	54.0	54.0	
E-W	Floor F2	n/a	1	Line	4.25	33.00	667.5	667.5	
Both	Wall 2-1	n/a	2	Line	0.00	18.75	54.0	54.0	
Both	Wall 2-2	n/a	2	Line	18.75	33.00	54.0	54.0	
E-W	Floor F3	n/a	4	Line	0.00	4.25	438.8	438.8	
E-W	Floor F1	n/a	5	Line	0.00	4.25	123.8	123.8	
E-W	Floor F1	n/a	6	Line	0.00	4.25	123.8	123.8	
E-W	Floor F2	n/a	6	Line	4.25	33.00	667.5	667.5	
N-S	Roof	Block 2	A	Line	38.25	89.00	313.5	313.5	
N-S	Roof	Block 2	C	Line	38.25	89.00	313.5	313.5	
Both	Wall A-1	n/a	A	Line	0.00	12.50	54.0	54.0	
N-S	Floor F1	n/a	A	Line	0.00	58.50	247.5	247.5	
Both	Wall A-2	n/a	A	Line	12.50	38.25	54.0	54.0	
N-S	Floor F3	n/a	A	Line	72.50	89.00	247.5	247.5	
N-S	Floor F2	n/a	B	Line	58.50	72.50	215.6	215.6	
Both	Wall C-1	n/a	C	Line	0.00	38.25	54.0	54.0	
N-S	Floor F1	n/a	C	Line	0.00	58.50	247.5	247.5	
N-S	Floor F2	n/a	C	Line	58.50	72.50	215.6	215.6	
N-S	Floor F3	n/a	C	Line	72.50	89.00	247.5	247.5	
Both	Wall 1-1	n/a	1	Line	0.00	3.00	54.0	54.0	
Both	Wall 1-2	n/a	1	Line	3.00	30.00	54.0	54.0	
Both	Wall 1-3	n/a	1	Line	30.00	33.00	54.0	54.0	
Both	Wall 2-1	n/a	2	Line	0.00	19.00	45.0	45.0	
Both	Wall 3-1	n/a	3	Line	0.00	19.00	45.0	45.0	
Both	Wall 4-1	n/a	4	Line	0.00	4.25	54.0	54.0	
Both	Wall 5-1	n/a	5	Line	0.00	4.25	54.0	54.0	
Both	Wall 6-1	n/a	6	Line	0.00	33.00	54.0	54.0	
Both	Wall A-1	n/a	A	Line	0.00	11.50	54.0	54.0	
Both	Wall A-2	n/a	A	Line	11.50	58.50	54.0	54.0	
Both	Wall A-3	n/a	A	Line	72.50	89.00	54.0	54.0	
Both	Wall B-1	n/a	B	Line	58.50	72.50	54.0	54.0	
Both	Wall C-1	n/a	C	Line	0.00	89.00	54.0	54.0	

WoodWorks® Shearwalls

BUILDING MASSES (continued)

Level 2 Force Dir	Building Element	Block	Wall Line	Profile	Location [ft]		Magnitude [lbs,plf,psf]		Trib Width [ft]
					Start	End	Start	End	
E-W	Floor F3	n/a	1	Line	0.00	4.25	438.8	438.8	
Both	Wall 1-1	n/a	1	Line	0.00	3.00	54.0	54.0	
Both	Wall 1-2	n/a	1	Line	3.00	30.00	54.0	54.0	
E-W	Floor F2	n/a	1	Line	4.25	33.00	667.5	667.5	
Both	Wall 1-3	n/a	1	Line	30.00	33.00	54.0	54.0	
Both	Wall 2-1	n/a	2	Line	0.00	19.00	45.0	45.0	
Both	Wall 3-1	n/a	3	Line	0.00	19.00	45.0	45.0	
Both	Wall 4-1	n/a	4	Line	0.00	4.25	54.0	54.0	
E-W	Floor F3	n/a	4	Line	0.00	4.25	438.8	438.8	
E-W	Floor F1	n/a	5	Line	0.00	4.25	123.8	123.8	
Both	Wall 5-1	n/a	5	Line	0.00	4.25	54.0	54.0	
Both	Wall 6-1	n/a	6	Line	0.00	33.00	54.0	54.0	
E-W	Floor F1	n/a	6	Line	0.00	4.25	123.8	123.8	
E-W	Floor F2	n/a	6	Line	4.25	33.00	667.5	667.5	
N-S	Floor F1	n/a	A	Line	0.00	58.50	247.5	247.5	
Both	Wall A-1	n/a	A	Line	0.00	11.50	54.0	54.0	
Both	Wall A-2	n/a	A	Line	11.50	58.50	54.0	54.0	
N-S	Floor F3	n/a	A	Line	72.50	89.00	247.5	247.5	
Both	Wall A-3	n/a	A	Line	72.50	89.00	54.0	54.0	
N-S	Floor F2	n/a	B	Line	58.50	72.50	215.6	215.6	
Both	Wall B-1	n/a	B	Line	58.50	72.50	54.0	54.0	
Both	Wall C-1	n/a	C	Line	0.00	89.00	54.0	54.0	
N-S	Floor F1	n/a	C	Line	0.00	58.50	247.5	247.5	
N-S	Floor F2	n/a	C	Line	58.50	72.50	215.6	215.6	
N-S	Floor F3	n/a	C	Line	72.50	89.00	247.5	247.5	
Both	Wall 1-1	n/a	1	Line	0.00	3.00	54.0	54.0	
Both	Wall 1-2	n/a	1	Line	3.00	30.00	54.0	54.0	
Both	Wall 1-3	n/a	1	Line	30.00	33.00	54.0	54.0	
Both	Wall 2-1	n/a	2	Line	0.00	19.00	45.0	45.0	
Both	Wall 3-1	n/a	3	Line	0.00	19.00	45.0	45.0	
Both	Wall 4-1	n/a	4	Line	0.00	4.25	54.0	54.0	
Both	Wall 5-1	n/a	5	Line	0.00	4.25	54.0	54.0	
Both	Wall 6-1	n/a	6	Line	0.00	33.00	54.0	54.0	
Both	Wall A-1	n/a	A	Line	0.00	11.50	54.0	54.0	
Both	Wall A-2	n/a	A	Line	11.50	58.50	54.0	54.0	
Both	Wall A-3	n/a	A	Line	72.50	89.00	54.0	54.0	
Both	Wall B-1	n/a	B	Line	58.50	72.50	54.0	54.0	
Both	Wall C-1	n/a	C	Line	0.00	89.00	54.0	54.0	
Level 1 Force Dir	Building Element	Block	Wall Line	Profile	Location [ft]		Magnitude [lbs,plf,psf]		Trib Width [ft]
E-W	Floor F1	n/a	1	Line	0.00	33.00	667.5	667.5	
Both	Wall 1-1	n/a	1	Line	0.00	3.00	54.0	54.0	
Both	Wall 1-2	n/a	1	Line	3.00	30.00	54.0	54.0	
Both	Wall 1-3	n/a	1	Line	30.00	33.00	54.0	54.0	
Both	Wall 2-1	n/a	2	Line	0.00	19.00	45.0	45.0	
Both	Wall 3-1	n/a	3	Line	0.00	19.00	45.0	45.0	
Both	Wall 4-1	n/a	4	Line	0.00	4.25	54.0	54.0	
Both	Wall 5-1	n/a	5	Line	0.00	4.25	54.0	54.0	
Both	Wall 6-1	n/a	6	Line	0.00	33.00	54.0	54.0	
E-W	Floor F1	n/a	6	Line	0.00	33.00	667.5	667.5	
Both	Wall A-1	n/a	A	Line	0.00	11.50	54.0	54.0	

WoodWorks® Shearwalls

BUILDING MASSES (continued)

N-S	Floor F1	n/a	A	Line	0.00	89.00	247.5	247.5
Both	Wall A-2	n/a	A	Line	11.50	58.50	54.0	54.0
Both	Wall A-3	n/a	A	Line	72.50	89.00	54.0	54.0
Both	Wall B-1	n/a	B	Line	58.50	72.50	54.0	54.0
Both	Wall C-1	n/a	C	Line	0.00	89.00	54.0	54.0
N-S	Floor F1	n/a	C	Line	0.00	89.00	247.5	247.5
Both	Wall 1-1	n/a	1	Line	0.00	7.50	88.5	88.5
Both	Wall 1-2	n/a	1	Line	7.50	25.50	88.5	88.5
Both	Wall 1-3	n/a	1	Line	25.50	33.00	88.5	88.5
Both	Wall 2-1	n/a	2	Line	0.00	19.00	73.8	73.8
Both	Wall 3-1	n/a	3	Line	0.00	19.00	73.8	73.8
Both	Wall 6-1	n/a	6	Line	0.00	7.50	88.5	88.5
Both	Wall 6-2	n/a	6	Line	7.50	25.50	88.5	88.5
Both	Wall 6-3	n/a	6	Line	25.50	33.00	88.5	88.5
Both	Wall A-1	n/a	A	Line	0.00	16.25	88.5	88.5
Both	Wall A-2	n/a	A	Line	16.25	38.00	88.5	88.5
Both	Wall A-3	n/a	A	Line	38.00	89.00	88.5	88.5
Both	Wall C-1	n/a	C	Line	0.00	29.00	88.5	88.5
Both	Wall C-2	n/a	C	Line	29.00	89.00	88.5	88.5

Legend:

Force Dir - Direction in which the mass is used for seismic load generation, E-W, N-S, or Both

Building element - Roof, gable end, wall or floor area used to generate mass, wall line for user-applied masses, Floor F# - refer to Plan View for floor area number

Wall line - Shearline that equivalent line load is assigned to

Location - Start and end points of equivalent line load on wall line

Trib Width. - Tributary width; for user applied area loads only

WoodWorks® Shearwalls

SEISMIC LOADS

Level 4					
Force Dir	Profile	Location [ft]		Mag [lbs,pf,psf]	
		Start	End	Start	End
E-W	Point	0.00	0.00	497	497
E-W	Line	0.00	18.75	203.0	201.9
E-W	Line	18.75	33.00	201.9	201.0
E-W	Point	33.00	33.00	497	497
N-S	Point	0.00	0.00	446	446
N-S	Line	0.00	12.50	177.0	177.0
N-S	Line	12.50	38.25	177.0	177.0
N-S	Point	38.25	38.25	446	446
Level 3					
Force Dir	Profile	Location [ft]		Mag [lbs,pf,psf]	
		Start	End	Start	End
E-W	Point	0.00	0.00	1195	1195
E-W	Line	0.00	3.00	489.9	489.9
E-W	Line	3.00	4.25	489.9	489.8
E-W	Point	4.25	4.25	148	148
E-W	Line	4.25	18.75	509.8	509.4
E-W	Line	18.75	19.00	509.4	509.4
E-W	Line	19.00	30.00	491.8	491.6
E-W	Line	30.00	33.00	491.6	491.5
E-W	Point	33.00	33.00	1343	1343
N-S	Point	0.00	0.00	696	696
N-S	Line	0.00	11.50	138.9	138.9
N-S	Line	11.50	12.50	138.9	138.9
N-S	Line	12.50	38.25	138.9	138.9
N-S	Point	38.25	38.25	515	515
N-S	Line	38.25	58.50	240.3	240.3
N-S	Point	47.00	47.00	167	167
N-S	Point	58.50	58.50	45	45
N-S	Line	58.50	72.50	227.9	227.9
N-S	Point	72.50	72.50	45	45
N-S	Line	72.50	89.00	240.3	240.3
N-S	Point	89.00	89.00	362	362
Level 2					
Force Dir	Profile	Location [ft]		Mag [lbs,pf,psf]	
		Start	End	Start	End
E-W	Point	0.00	0.00	1133	1133
E-W	Line	0.00	3.00	243.1	243.1
E-W	Line	3.00	4.25	243.1	243.1
E-W	Point	4.25	4.25	212	212
E-W	Line	4.25	19.00	242.2	242.2
E-W	Line	19.00	30.00	217.0	217.0
E-W	Line	30.00	33.00	217.0	217.0
E-W	Point	33.00	33.00	1345	1345
N-S	Point	0.00	0.00	499	499
N-S	Line	0.00	11.50	99.5	99.5
N-S	Line	11.50	58.50	99.5	99.5
N-S	Point	38.25	38.25	239	239
N-S	Point	47.00	47.00	239	239
N-S	Point	58.50	58.50	64	64
N-S	Line	58.50	72.50	90.6	90.6
N-S	Point	72.50	72.50	64	64
N-S	Line	72.50	89.00	99.5	99.5
N-S	Point	89.00	89.00	499	499
Level 1					
Force Dir	Profile	Location [ft]		Mag [lbs,pf,psf]	
		Start	End	Start	End
E-W	Point	0.00	0.00	1007	1007
E-W	Line	0.00	3.00	166.0	166.0
E-W	Line	3.00	4.25	166.0	166.0
E-W	Point	4.25	4.25	64	64
E-W	Line	4.25	7.50	156.9	156.9

WoodWorks® Shearwalls

SEISMIC LOADS (continued)

E-W	Line	7.50	19.00	156.9	156.9
E-W	Line	19.00	25.50	136.8	136.8
E-W	Line	25.50	30.00	136.8	136.8
E-W	Line	30.00	33.00	136.8	136.8
E-W	Point	33.00	33.00	1071	1071
N-S	Point	0.00	0.00	397	397
N-S	Line	0.00	11.50	65.9	65.9
N-S	Line	11.50	16.25	65.9	65.9
N-S	Line	16.25	29.00	65.9	65.9
N-S	Line	29.00	38.00	65.9	65.9
N-S	Line	38.00	58.50	65.9	65.9
N-S	Point	38.25	38.25	191	191
N-S	Point	47.00	47.00	191	191
N-S	Point	58.50	58.50	19	19
N-S	Line	58.50	72.50	65.9	65.9
N-S	Point	72.50	72.50	19	19
N-S	Line	72.50	89.00	65.9	65.9
N-S	Point	89.00	89.00	397	397

Legend:

*Loads in table can be accumulation of loads from several building masses, so they do not correspond with a particular building element.
Location - Start and end of load in direction perpendicular to seismic force direction*

Notes:

All loads entered by the user or generated by program are specified (unfactored) loads. The program applies a load factor of 0.70 and redundancy factor to seismic loads before distributing them to the shearlines.

WoodWorks® Shearwalls

Design Summary

SHEARWALL DESIGN

Wind Shear Loads, Flexible Diaphragm

All shearwalls have sufficient design capacity.

Seismic Loads, Flexible Diaphragm

The following under-capacity shear walls were found:

HOLD-DOWN DESIGN

Wind Loads, Flexible Diaphragm

Under-capacity hold-downs were found on the following walls:

Level 1: A-2, 1-1, 1-3, 2-1, 3-1, 6-1, 6-3

Level 2: 1-1, 2-1

Level 3: 1-1

Seismic Loads, Flexible Diaphragm

Under-capacity hold-downs were found on the following walls:

Level 1: A-2, 1-1, 1-3, 2-1, 3-1, 6-1, 6-3

Level 2: A-2, 1-1, 2-1, 3-1

Level 3: 1-1

COMPRESSION FORCE DESIGN

Wind Loads, Flexible Diaphragm

Force under end studs exceeded perpendicular-to-grain compressive capacity for the following walls:

Level 1: C-2, 1-1, 1-3, 2-1, 3-1, 6-1, 6-3

Level 2: C-1, 1-1, 2-1

Level 3: 1-1

Seismic Loads, Flexible Diaphragm

Force under end studs exceeded perpendicular-to-grain compressive capacity for the following walls:

Level 1: C-2, 1-1, 1-3, 2-1, 3-1, 6-1, 6-3

Level 2: A-2, C-1, 1-1, 2-1

Level 3: C-1, 1-1

This Design Summary does not include failures that occur due to excessive story drift from ASCE 7 CC.2.2 (wind) or 12.12 (seismic). Refer to Story Drift table in this report to verify this design criterion.

Refer to the Deflection table for possible issues regarding fastener slippage (SDPWS Table C4.2.3D).

WoodWorks® Shearwalls

Flexible Diaphragm Wind Design ASCE 7 Directional (All Heights) Loads

SHEAR RESULTS

N-S Shearlines	W Gp	For Dir	ASD Shear Force [plf]			Asp-Cub		Allowable Shear [plf]					Resp. Ratio	
			v	vmax/vft	V [lbs]	Int	Ext	Int	Ext	Co	C	Cmb		V [lbs]
Line 1														
Level 4														
Ln1, Lev4	-	S->N	-	-	1920	-	-	-	-	-	-	8777	-	
	-	N->S	-	-	1899	-	-	-	-	-	-	8777	-	
Wall 1-1	7	S->N	-	-	1920	-	1.0	-	685	-	-	8777	-	
	7	N->S	-	-	1899	-	1.0	-	685	-	-	8777	-	
Seg. 1	-	S->N	7.9	-	24	-	.88	-	599	-	599	1798	0.01	
	-	N->S	45.8	-	137	-	.88	-	599	-	599	1798	0.08	
Seg. 2	-	S->N	241.5	-	1751	-	1.0	-	685	-	685	4966	0.35	
	-	N->S	210.7	-	1527	-	1.0	-	685	-	685	4966	0.31	
Seg. 3	-	S->N	44.7	-	145	-	.90	-	619	-	619	2012	0.07	
	-	N->S	71.9	-	234	-	.90	-	619	-	619	2012	0.12	
Level 3														
Ln1, Lev3	-	S->N	-	-	5959	-	-	-	-	-	-	14943	-	
	-	N->S	-	-	5937	-	-	-	-	-	-	14943	-	
Wall 1-1	6	S->N	-	-	5959	1.0	1.0	175	991	-	A	14943	-	
	6	N->S	-	-	5937	1.0	1.0	175	991	-	A	14943	-	
Seg. 1	-	S->N	435.2	-	1306	.88	.88	153	867	-	-	1021	3062	0.43
	-	N->S	33.8	-	101	.88	.88	153	867	-	-	1021	3062	0.03
Seg. 2	-	S->N	624.9	-	4530	1.0	1.0	175	991	-	-	1166	8456	0.54
	-	N->S	804.9	-	5836	1.0	1.0	175	991	-	-	1166	8456	0.69
Seg. 3	-	S->N	37.9	-	123	.90	.90	158	896	-	-	1054	3426	0.04
	-	N->S	0.0	-	0	.90	.90	158	896	-	-	1054	3426	0.00
Level 2														
Ln1, Lev2	-	S->N	-	-	9975	-	-	-	-	-	-	25402	-	
	-	N->S	-	-	9955	-	-	-	-	-	-	25402	-	
Wall 1-1	5^	S->N	-	-	9975	1.0	1.0	991	991	-	A	25402	-	
	5	N->S	-	-	9955	1.0	1.0	991	991	-	A	25402	-	
Seg. 1	-	S->N	113.0	-	339	.88	.88	867	867	-	-	1735	5204	0.07
	-	N->S	500.5	-	1502	.88	.88	867	867	-	-	1735	5204	0.29
Seg. 2	-	S->N	1051.1	-	7621	1.0	1.0	991	991	-	-	1983	14374	0.53
	-	N->S	924.0	-	6699	1.0	1.0	991	991	-	-	1983	14374	0.47
Seg. 3	-	S->N	620.2	-	2016	.90	.90	896	896	-	-	1792	5824	0.35
	-	N->S	540.0	-	1755	.90	.90	896	896	-	-	1792	5824	0.30
Level 1														
Ln1, Lev1	-	S->N	-	-	14649	-	-	-	-	-	-	22632	-	
	-	N->S	-	-	14631	-	-	-	-	-	-	22632	-	
Wall 1-1	1^	S->N	1064.2	-	7982	1.0	1.0	754	754	-	A	1509	11316	0.71
	1	N->S	919.1	-	6894	1.0	1.0	754	754	-	A	1509	11316	0.61
Wall 1-3	1	S->N	889.0	-	6667	1.0	1.0	754	754	-	A	1509	11316	0.59
	1	N->S	1031.6	-	7737	1.0	1.0	754	754	-	A	1509	11316	0.68
Line 2														
Level 4														
Ln2, Lev4	2	S->N	116.3	116.3	1920	1.0	1.0	70	365	1.00	A	435	7178	0.27
	2	N->S	115.1	115.1	1899	1.0	1.0	70	365	1.00	A	435	7178	0.26
Level 3														
Ln2, Lev3	-	S->N	-	-	5388	-	-	-	-	-	-	13015	-	
	-	N->S	-	-	5370	-	-	-	-	-	-	13015	-	
Wall 2-1	7	S->N	283.6	-	5388	-	1.0	-	685	-	-	685	13015	0.41
	7	N->S	282.6	-	5370	-	1.0	-	685	-	-	685	13015	0.41
Level 2														
Ln2, Lev2	-	S->N	-	-	9361	-	-	-	-	-	-	13015	-	
	-	N->S	-	-	9344	-	-	-	-	-	-	13015	-	
Wall 2-1	7	S->N	492.7	-	9361	-	1.0	-	685	-	-	685	13015	0.72
	7	N->S	491.8	-	9344	-	1.0	-	685	-	-	685	13015	0.72
Level 1														
Ln2, Lev1	-	S->N	-	-	13983	-	-	-	-	-	-	17005	-	
	-	N->S	-	-	13968	-	-	-	-	-	-	17005	-	
Wall 2-1	8	S->N	735.9	-	13983	-	1.0	-	895	-	-	895	17005	0.82
	8	N->S	735.1	-	13968	-	1.0	-	895	-	-	895	17005	0.82
Line 3														
Level 3														
Ln3, Lev3	-	S->N	-	-	2734	-	-	-	-	-	-	9590	-	
	-	N->S	-	-	2714	-	-	-	-	-	-	9590	-	
Wall 3-1	7	S->N	-	-	2734	-	1.0	-	685	-	-	9590	-	
	7	N->S	-	-	2714	-	1.0	-	685	-	-	9590	-	
Seg. 1	-	Both	0.0	-	0	-	1.0	-	685	-	-	685	-	

WoodWorks® Shearwalls

SHEAR RESULTS (flexible wind design, continued)

Seg. 2	-	S->N	195.3	-	2734	-	1.0	-	685	-	685	9590	0.29	
	-	N->S	193.8	-	2714	-	1.0	-	685	-	685	9590	0.28	
Level 2														
Ln3, Lev2	-	S->N	-	-	7023	-	-	-	-	-	-	9590	-	
	-	N->S	-	-	7005	-	-	-	-	-	-	9590	-	
Wall 3-1	7	S->N	-	-	7023	-	1.0	-	685	-	-	9590	-	
	7	N->S	-	-	7005	-	1.0	-	685	-	-	9590	-	
Seg. 1	-	Both	0.0	-	0	-	1.0	-	685	-	685	-	-	
Seg. 2	-	S->N	501.6	-	7023	-	1.0	-	685	-	685	9590	0.73	
	-	N->S	500.3	-	7005	-	1.0	-	685	-	685	9590	0.73	
Level 1														
Ln3, Lev1	-	S->N	-	-	12014	-	-	-	-	-	-	12530	-	
	-	N->S	-	-	11998	-	-	-	-	-	-	12530	-	
Wall 3-1	8^	S->N	-	-	12014	-	1.0	-	895	-	-	12530	-	
	8	N->S	-	-	11998	-	1.0	-	895	-	-	12530	-	
Seg. 1	-	Both	0.0	-	0	-	1.0	-	895	-	895	-	-	
Seg. 2	-	S->N	858.1	-	12014	-	1.0	-	895	-	895	12530	0.96	
	-	N->S	857.0	-	11998	-	1.0	-	895	-	895	12530	0.96	
Line 6														
Level 3														
Ln6, Lev3	2	S->N	115.0	125.6	2962	1.0	1.0	64	334	0.92	A	398	10256	0.29
	2	N->S	114.3	124.8	2943	1.0	1.0	64	334	0.92	A	398	10256	0.29
Level 2														
Ln6, Lev2	9	S->N	286.3	312.7	7372	1.0	1.0	64	488	0.92	A	552	14205	0.52
	9	N->S	285.6	312.0	7355	1.0	1.0	64	488	0.92	A	552	14205	0.52
Level 1														
Ln6, Lev1	-	S->N	-	-	12504	-	-	-	-	-	-	22632	-	
	-	N->S	-	-	12489	-	-	-	-	-	-	22632	-	
Wall 6-1	1	S->N	942.0	-	7065	1.0	1.0	754	754	-	A	1509	11316	0.62
	1	N->S	724.7	-	5435	1.0	1.0	754	754	-	A	1509	11316	0.48
Wall 6-3	1	S->N	725.1	-	5438	1.0	1.0	754	754	-	A	1509	11316	0.48
	1	N->S	940.5	-	7054	1.0	1.0	754	754	-	A	1509	11316	0.62
E-W Shearlines		W Gp	For Dir ASD Shear Force [plf]			Asp-Cub		Allowable Shear [plf]						Resp. Ratio
			v	vmax/vft	V [lbs]	Int	Ext	Int	Ext	Co	C	Cmb	V [lbs]	
Line A														
Level 4														
LnA, Lev4	4	Both	103.9	118.4	1273	1.0	1.0	61	601	0.88	A	662	8115	0.16
Level 3														
LnA, Lev3	-	W->E	-	-	4564	-	-	-	-	-	-	-	21270	-
	-	E->W	-	-	4582	-	-	-	-	-	-	-	21270	-
Wall A-2	4	W->E	101.8	138.3	2979	.95	.95	52	504	0.78	A	556	16257	0.18
	4	E->W	102.3	139.0	2993	.95	.95	52	504	0.78	A	556	16257	0.18
Wall A-3	4	W->E	155.1	256.9	1706	.84	.84	42	413	0.72	A	456	5013	0.34
	4	E->W	155.5	257.6	1710	.84	.84	42	413	0.72	A	456	5013	0.34
Level 2														
LnA, Lev2	-	W->E	-	-	7933	-	-	-	-	-	-	-	24581	-
	-	E->W	-	-	7952	-	-	-	-	-	-	-	24581	-
Wall A-2	3	W->E	271.2	362.9	7933	-	.95	-	669	0.79	-	669	19568	0.41
	3	E->W	271.9	363.7	7952	-	.95	-	669	0.79	-	669	19568	0.41
Wall A-3	4	Both	0.0	-	0	.84	.84	42	413	0.72	A	456	5013	0.00
Level 1														
LnA, Lev1	-	W->E	-	-	11340	-	-	-	-	-	-	-	38254	-
	-	E->W	-	-	11359	-	-	-	-	-	-	-	38254	-
Wall A-2	1	W->E	390.4	-	8490	1.0	1.0	754	754	-	A	1509	32816	0.26
	1	E->W	394.5	-	8580	1.0	1.0	754	754	-	A	1509	32816	0.26
Wall A-3	2	W->E	228.0	228.0	2850	1.0	1.0	70	365	1.00	A	435	5438	0.52
	2	E->W	222.3	222.3	2779	1.0	1.0	70	365	1.00	A	435	5438	0.51
Line C														
Level 4														
LnC, Lev4	2	Both	60.6	80.3	1242	.95	.95	53	275	0.79	A	328	6726	0.18
Level 3														
LnC, Lev3	2	W->E	63.1	71.4	4147	1.0	1.0	62	322	0.88	A	384	25257	0.16
	2	E->W	63.2	71.6	4156	1.0	1.0	62	322	0.88	A	384	25257	0.16
Level 2														
LnC, Lev2	2	W->E	108.4	117.0	6913	.99	.99	65	338	0.93	A	403	25706	0.27
	2	E->W	108.6	117.2	6923	.99	.99	65	338	0.93	A	403	25706	0.27
Level 1														
LnC, Lev1	-	W->E	-	-	10077	-	-	-	-	-	-	-	59423	-
	-	E->W	-	-	10086	-	-	-	-	-	-	-	59423	-
Wall C-1	1	W->E	256.8	-	7448	1.0	1.0	754	754	-	A	1509	43755	0.17
	1	E->W	256.5	-	7438	1.0	1.0	754	754	-	A	1509	43755	0.17
Wall C-2	2	W->E	66.2	73.1	2632	.95	.95	63	331	0.96	A	394	15668	0.17

WoodWorks® Shearwalls

SHEAR RESULTS (flexible wind design, continued)

2	E->W	66.7	73.6	2652	.95	.95	63	331	0.96	A	394	15668	0.17
---	------	------	------	------	-----	-----	----	-----	------	---	-----	-------	------

Legend:

W Gp - Wall design group defined in Sheathing and Framing Materials tables, where it shows associated Standard Wall. "^" means that this wall is critical for all walls in the Standard Wall group.

For Dir - Direction of wind force along shearline.

v - Design shear force on segment = ASD-factored shear force per unit length of full-height sheathing (FHS)

vmax/vft - Perforated walls: Collector and in-plane anchorage force as per SDPWS eqn. 4.3-9 = $V/FHS/Co$. FHS is factored for narrow segments as per 4.3.3.4

FTAO walls: Shear force in piers above and below either openings or piers beside opening(s). Aspect ratio factor does not apply to these piers.

V - ASD factored shear force. For shearline: total shearline force. For wall: total of all segments on wall. For segment: force on segment

Asp/Cub - Unblocked wood structural panel factor *Cub* from SDPWS 4.3.5.3 or Aspect Ratio factor from 4.3.3.2, which for perforated walls is sum b_i / FHS from 4.3.5.6 with b_i defined in 4.3.3.4. For multi-segment walls, wall row shows *Cub* and segment rows show *Asp*. For single-segment walls and perforated walls, value shown is *Asp* for blocked walls and *Cub* for unblocked walls.

Int, Ext - Nominal unit shear capacity of interior and exterior sheathing, factored by Table 4.3-1 Note 3 for framing specific gravity and Note 10 for presence of hold-downs. For wall segments, also include unblocked factor *Cub* and aspect ratio adjustments.

Co - Adjustment factor for perforated walls from SDPWS Equation 4.3-6.

C - Sheathing combination rule, A = Add capacities, S = Strongest side or twice weakest, G = Stiffness-based using Eqns. 4.3-3,-4.

Cmb - Combined interior and exterior unit shear capacity including perforated wall factor *Co*.

V - Total factored shear capacity of shearline, wall or segment.

Crit Resp - Response ratio = v/Cmb = design shear force/unit shear capacity. "S" indicates that the seismic design criterion was critical in selecting wall.

Notes:

Refer to Elevation View diagrams for individual level for uplift anchorage force *t* for perforated walls given by SDPWS 4.3.6.4.2,1.

WoodWorks® Shearwalls

Hold-Down and Compression Design (flexible wind design)

Level 1 Line-Wall	Posit'n	Location [ft]		Load Case	Tensile Hold-down or Compressive Stud Force [lbs]				Hold-down	Cap [lbs]	Crit Resp.
		X	Y		Shear	Dead	Uplift	Cmb'd			
Line 1											
1-1	L End	0.00	0.12	2	21702	690		21012	HDU5-SDS	5645	3.72*
1-1	L End	0.00	0.12	2	19737	1150		20887	Compression	10312	2.03*
	V Elem	0.00	2.88	2	5713	1239		4473	Refer to upper level		
	V Elem	0.00	2.88	2	5463	2066		7528	Compression		
1-2	L Op 2	0.00	3.88	1		0	620	619	Compression		
1-1	R End	0.00	7.38	2	14025	398		13627	HDU5-SDS	5645	2.41*
1-1	R End	0.00	7.38	2	16239	664		16902	Compression	10312	1.64*
	V Elem	0.00	11.13	1		0	620	619	Compression		
	V Elem	0.00	12.88	2	17917	1792		16125	Refer to upper level		
	V Elem	0.00	12.88	2	18118	2987		21104	Compression		
1-3	L End	0.00	25.63	2	13564	398		13166	HDU5-SDS	5645	2.33*
1-3	L End	0.00	25.63	2	15741	664		16405	Compression	10312	1.59*
	V Elem	0.00	29.13	2	7785	1560		6225	Refer to upper level		
	V Elem	0.00	29.13	2	7699	2599		10298	Compression		
	V Elem	0.00	29.88	2	6853	1264		5589	Refer to upper level		
	V Elem	0.00	29.88	2	5967	2106		8073	Compression		
1-3	R End	0.00	32.88	2	21708	714		20994	HDU5-SDS	5645	3.72*
1-3	R End	0.00	32.88	2	20417	1190		21607	Compression	10312	2.10*
Line 2											
2-1	L End	38.25	0.12	1	19172	2474		16698	HDU5-SDS	5645	2.96*
2-1	L End	38.25	0.12	1	19131	4124		23255	Compression	10312	2.26*
	V Elem	38.25	18.63	1	19131	2547		16584	Refer to upper level		
	V Elem	38.25	18.63	1	19172	4245		23417	Compression		
	V Elem	38.25	21.13	1		0	122	121	Compression		
Line 3											
	V Elem	47.00	1.88	1		0	491	491	Compression		
3-1	R Op 1	47.00	5.13	1	19274	1670		17604	HDU5-SDS	5645	3.12*
3-1	R Op 1	47.00	5.13	1	19231	2784		22015	Compression	10312	2.13*
3-1	R End	47.00	18.88	1	19231	1376		17856	HDU5-SDS	5645	3.16*
3-1	R End	47.00	18.88	1	19274	2293		21566	Compression	10312	2.09*
Line 6											
6-1	L End	89.00	0.12	2	18380	2537		15843	HDU5-SDS	5645	2.81*
6-1	L End	89.00	0.12	2	15049	4228		19276	Compression	10312	1.87*
6-2	L Op 1	89.00	1.88	1		0	2567	2566	Compression		
6-1	R End	89.00	7.38	2	11057	398		10673	HDU5-SDS	5645	1.89*
6-1	R End	89.00	7.38	2	14374	664		15024	Compression	10312	1.46*
6	t @ Op 1	89.00	7.50	2		96		96	HDU5-SDS	5645	0.02
6	t @ Op 2	89.00	10.25	2		986		986	HDU5-SDS	5645	0.17
6	t @ Op 2	89.00	14.50	2		986		986	HDU5-SDS	5645	0.17
6	t @ Op 3	89.00	17.00	2		1260		1260	HDU5-SDS	5645	0.22
6	t @ Op 3	89.00	22.50	2		1260		1260	HDU5-SDS	5645	0.22
6	t @ Op 4	89.00	25.25	2		96		96	HDU5-SDS	5645	0.02
6-3	L End	89.00	25.63	2	11064	398		10680	HDU5-SDS	5645	1.89*
6-3	L End	89.00	25.63	2	14351	664		15001	Compression	10312	1.45*
6-2	R Op 1	89.00	31.13	1		0	2566	2566	Compression		
6-3	R End	89.00	32.88	2	18342	2537		15806	HDU5-SDS	5645	2.80*
6-3	R End	89.00	32.88	2	15070	4228		19297	Compression	10312	1.87*
Line A											
	V Elem	1.88	0.00	1	380	3065		3445	Compression		
A	t @ Op 1	11.50	0.00	1		976		976	HDU5-SDS	5645	0.17
A	t @ Op 1	12.25	0.00	1		69		69	HDU5-SDS	5645	0.01
	V Elem	12.63	0.00	1	5259	5002		770	Refer to upper level		
	V Elem	12.63	0.00	1	5271	8337		13094	Compression		
A-2	L End	16.38	0.00	1	5825	1155		5937	HDU5-SDS	5645	1.05*
A-2	L End	16.38	0.00	1	5886	1925		6544	Compression	10312	0.63
	V Elem	29.38	0.00	1	1088	753		335	Refer to upper level		
	V Elem	29.38	0.00	1	1088	1256		2344	Compression		
	V Elem	35.88	0.00	1		0	338	337	Compression		
A-2	R End	37.88	0.00	1	5886	1155		5484	HDU5-SDS	5645	0.97
A-2	R End	37.88	0.00	1	5825	1925		6996	Compression	10312	0.68
A	t @ Op 3	41.00	0.00	1		610	266	610	HDU5-SDS	5645	0.11

WoodWorks® Shearwalls

Hold-Down and Compression Design (flexible wind design, continued)

A	t @ Op 4	44.25	0.00	1	737	266	737	HDU5-SDS	5645	0.13
A	t @ Op 4	48.00	0.00	1	737	266	737	HDU5-SDS	5645	0.13
A-3	L End	51.38	0.00	1	3432	823	2609	HDU5-SDS	5645	0.46
A-3	L End	51.38	0.00	1	3346	1372	4718	Compression	10312	0.46
	V Elem	58.38	0.00	1	4563	3133	1430	Refer to upper level		
	V Elem	58.38	0.00	1	4550	5222	9772	Compression		
A-3	R End	63.63	0.00	1	3346	823	2523	HDU5-SDS	5645	0.45
A-3	R End	63.63	0.00	1	3432	1372	4803	Compression	10312	0.47
A-3	R Op 6	66.88	0.00	1	0	266	265	Compression	10312	0.03
	V Elem	69.88	0.00	1	296	293	18	Refer to upper level		
	V Elem	69.88	0.00	1	297	488	770	Compression		
A	t @ Op 1	72.50	0.00	1	578		578	HDU5-SDS	5645	0.10
	V Elem	73.13	0.00	1	2070	1095	1089	Refer to upper level		
	V Elem	73.13	0.00	1	2076	1825	3787	Compression		
A	t @ Op 1	76.75	0.00	1	317	266	317	HDU5-SDS	5645	0.06
A	t @ Op 2	79.75	0.00	1	385		385	HDU5-SDS	5645	0.07
A-3	t @ Op 6	80.13	0.00	1	206	266		Compression	10312	0.02
A	t @ Op 2	82.50	0.00	1	385		385	HDU5-SDS	5645	0.07
A-3	t @ Op 6	82.88	0.00	1	251	266		Compression	10312	0.02
A	t @ Op 3	85.50	0.00	1	450		450	HDU5-SDS	5645	0.08
A-3	t @ Op 6	86.13	0.00	1	152	266		Compression	10312	0.01
	V Elem	88.88	0.00	1	2372	1069	1753	Refer to upper level		
	V Elem	88.88	0.00	1	2366	1782	3698	Compression		
Line C										
C-1	L End	0.12	33.00	1	3821	1915	1906	HDU5-SDS	5645	0.34
C-1	L End	0.12	33.00	1	3816	6270	10086	Compression	10312	0.98
	V Elem	1.88	33.00	1	0	405	405	Compression		
	V Elem	4.62	33.00	1	2437	16606	19043	Compression		
	t @ Elem	12.38	33.00	1	18			Refer to upper level		
	t @ Elem	14.88	33.00	1	53			Refer to upper level		
	t @ Elem	18.63	33.00	1	171			Refer to upper level		
	t @ Elem	21.13	33.00	1	171			Refer to upper level		
	t @ Elem	23.13	33.00	1	100			Refer to upper level		
	t @ Elem	25.88	33.00	1	100			Refer to upper level		
C-1	R End	28.88	33.00	1	3816	3048	907	HDU5-SDS	5645	0.16
C-1	R End	28.88	33.00	1	3821	2589	6271	Compression	10312	0.61
C	t @ Op 4	29.25	33.00	1	55		55	HDU5-SDS	5645	0.01
C	t @ Op 4	29.50	33.00	1	63		63	HDU5-SDS	5645	0.01
C	t @ Op 4	31.00	33.00	1	298		298	HDU5-SDS	5645	0.05
C-2	t @ Op 5	32.62	33.00	1	334	525		Compression	10312	0.03
C-2	L End	35.88	33.00	1	1093	9310	10087	Compression	10312	0.98
	V Elem	38.13	33.00	1	732	732	0	Refer to upper level		
	V Elem	38.13	33.00	1	732	1823	2554	Compression		
C-2	t @ Op 5	48.13	33.00	1	282		282	HDU5-SDS	5645	0.05
C-2	t @ Op 5	51.38	33.00	1	282		282	HDU5-SDS	5645	0.05
C-2	t @ Op 5	52.63	33.00	1	329		329	HDU5-SDS	5645	0.06
C-2	t @ Op 5	56.38	33.00	1	329		329	HDU5-SDS	5645	0.06
C-2	t @ Op 5	71.63	33.00	1	176		176	HDU5-SDS	5645	0.03
C-2	t @ Op 5	74.62	33.00	1	247		247	HDU5-SDS	5645	0.04
C-2	R End	88.88	33.00	1	2798	2798	0	Not required	5645	0.00

WoodWorks® Shearwalls

Hold-Down and Compression Design (flexible wind design, continued)

Line	Line-Wall	Posit'n	Location [ft]		Load Case	Tensile Hold-down or Compressive Stud Force [lbs]			Hold-down	Cap [lbs]	Crit Resp.	
			X	Y		Shear	Dead	Uplift	Cmb'd			
C-2	R End		88.88	33.00	1	2787	13839		16625	Compression	10312	1.61*
Level 2												
Line 1												
1-1	L End		0.00	0.12	2	5463	292		5171	HDU5-SDS	5645	0.92
1-1	L End		0.00	0.12	2	5713	486		6198	Compression	10312	0.60
1-1	L Op 1		0.00	2.88	2	5713	1239		4473	HDU5-SDS	5645	0.79
1-1	L Op 1		0.00	2.88	2	5463	2066		7528	Compression	10312	0.73
1-1	R Op 1		0.00	12.88	2	17917	1652		16265	HDU5-SDS	5645	2.88*
1-1	R Op 1		0.00	12.88	2	18118	2754		20872	Compression	10312	2.02*
1-1	L Op 2		0.00	19.88	2	18118	1652		16465	HDU5-SDS	5645	2.92*
1-1	L Op 2		0.00	19.88	2	17917	2754		20671	Compression	10312	2.00*
1-1	R Op 2		0.00	29.88	2	6853	1264		5589	HDU5-SDS	5645	0.99
1-1	R Op 2		0.00	29.88	2	5967	2106		8073	Compression	10312	0.78
1-1	R End		0.00	32.88	2	5967	316		5651	HDU5-SDS	5645	1.00
1-1	R End		0.00	32.88	2	6853	527		7379	Compression	10312	0.72
Line 2												
2-1	L End		38.25	0.12	1	8172	1634		6539	HDU5-SDS	5645	1.16*
2-1	L End		38.25	0.12	1	8143	2723		10865	Compression	10312	1.05*
	V Elem		38.25	18.63	1	8143	1706		6436	Refer to upper level		
	V Elem		38.25	18.63	1	8172	2844		11016	Compression		
	V Elem		38.25	21.13	1	0	122		121	Compression		
Line 3												
	V Elem		47.00	1.88	1	0	270		270	Compression		
3-1	R Op 1		47.00	5.13	1	6386	918		5468	HDU5-SDS	5645	0.97
3-1	R Op 1		47.00	5.13	1	6361	1530		7891	Compression	10312	0.77
3-1	R End		47.00	18.88	1	6361	756		5605	HDU5-SDS	5645	0.99
3-1	R End		47.00	18.88	1	6386	1260		7646	Compression	10312	0.74
Line 6												
6-1	L End		89.00	0.12	2	4005	2138		1867	HDU5-SDS	5645	0.33
6-1	L End		89.00	0.12	2	3991	3564		7555	Compression	10312	0.73
6-1	R End		89.00	32.88	2	3991	2138		1853	HDU5-SDS	5645	0.33
6-1	R End		89.00	32.88	2	4005	3564		7569	Compression	10312	0.73
Line A												
	V Elem		1.88	0.00	1	105	1876		1981	Compression		
A-2	L End		11.63	0.00	1	3294	1864		1430	HDU5-SDS	5645	0.25
A-2	L End		11.63	0.00	1	3302	3115		6416	Compression	10312	0.62
	V Elem		12.63	0.00	1	2245	4552		6797	Compression		
	V Elem		29.38	0.00	1	1088	753		335	Refer to upper level		
	V Elem		29.38	0.00	1	1088	1256		2344	Compression		
	V Elem		35.88	0.00	1	0	338		337	Compression		
A-2	R End		58.38	0.00	1	4563	3133		1430	HDU5-SDS	5645	0.25
A-2	R End		58.38	0.00	1	4550	5222		9772	Compression	10312	0.95
	V Elem		72.63	0.00	1	2366	1069		1297	Refer to upper level		
	V Elem		72.63	0.00	1	2372	1782		4154	Compression		
	V Elem		88.88	0.00	1	2372	1069		1303	Refer to upper level		
	V Elem		88.88	0.00	1	2366	1782		4148	Compression		
Line C												
C-1	L Op 1		1.88	33.00	1	0	405		405	Compression	10312	0.04
C-1	L End		4.62	33.00	1	2437	16606		19043	Compression	10312	1.85*
C-1	t @ Op		12.38	33.00	1	18			18	HDU5-SDS	5645	0.00
C-1	t @ Op		14.88	33.00	1	53			53	HDU5-SDS	5645	0.01
C-1	t @ Op		18.63	33.00	1	171			171	HDU5-SDS	5645	0.03
C-1	t @ Op		21.13	33.00	1	171			171	HDU5-SDS	5645	0.03
	t @ Elem		23.13	33.00	1	100				Refer to upper level		
	t @ Elem		25.88	33.00	1	100				Refer to upper level		
C-1	t @ Op		31.13	33.00	1	89			89	HDU5-SDS	5645	0.02
C-1	t @ Op		33.87	33.00	1	89			89	HDU5-SDS	5645	0.02
	V Elem		38.13	33.00	1	732	732		0	Refer to upper level		
	V Elem		38.13	33.00	1	732	1823		2554	Compression		
C-1	R End		88.88	33.00	1	1705	1705		0	Not required		
C-1	R End		88.88	33.00	1	1702	9126		10828	Compression	10312	1.05*
Level 3												
Line-			Location [ft]		Load	Tensile Hold-down or Compressive Stud Force [lbs]			Cap	Crit		

WoodWorks® Shearwalls

Hold-Down and Compression Design (flexible wind design, continued)

Wall	Posit'n	X	Y	Case	Shear	Dead	Uplift	Cmb'd	Hold-down	[lbs]	Resp.
Line 1											
1-1	L End	0.00	0.12	2	4354	194		4159	HDU5-SDS	5645	0.74
1-1	L End	0.00	0.12	2	798	277		1075	Compression	10312	0.10
1-1	L Op 1	0.00	2.88	2	798	798		0	Not required	5645	0.00
1-1	L Op 1	0.00	2.88	2	4354	1377		5730	Compression	10312	0.56
1-1	R Op 1	0.00	12.88	2	8119	1102		7018	HDU5-SDS	5645	1.24*
1-1	R Op 1	0.00	12.88	2	9505	1836		11341	Compression	10312	1.10*
1-1	L Op 2	0.00	19.88	2	9505	1102		8403	HDU5-SDS	5645	1.49*
1-1	L Op 2	0.00	19.88	2	8119	1836		9955	Compression	10312	0.97
1-1	R Op 2	0.00	29.88	2	806	806		0	Refer to upper level		
	V Elem	0.00	29.88	2	703	1404		2106	Compression		
	V Elem	0.00	32.88	2	703	211		492	HDU5-SDS	5645	0.09
1-1	R End	0.00	32.88	2	806	290		1095	Compression	10312	0.11
Line 2											
2-1	L End	38.25	0.12	1	3679	1121		2558	HDU5-SDS	5645	0.45
2-1	L End	38.25	0.12	1	3658	1867		5525	Compression	10312	0.54
	V Elem	38.25	18.63	1	3658	1193		2464	Refer to upper level		
	V Elem	38.25	18.63	1	3679	1989		5668	Compression		
	V Elem	38.25	21.13	1	0	122		121	Compression		
Line 3											
	V Elem	47.00	1.88	1	0	135		135	Compression		
3-1	R Op 1	47.00	5.13	1	1789	459		1330	HDU5-SDS	5645	0.24
3-1	R Op 1	47.00	5.13	1	1776	765		2541	Compression	10312	0.25
3-1	R End	47.00	18.88	1	1776	378		1398	HDU5-SDS	5645	0.25
3-1	R End	47.00	18.88	1	1789	630		2419	Compression	10312	0.23
Line 6											
6-1	L End	89.00	0.12	2	1164	1069		94	HDU5-SDS	5645	0.02
6-1	L End	89.00	0.12	2	1156	1782		2938	Compression	10312	0.28
6-1	R End	89.00	32.88	2	1156	1069		87	HDU5-SDS	5645	0.02
6-1	R End	89.00	32.88	2	1164	1782		2946	Compression	10312	0.29
Line A											
	V Elem	1.88	0.00	1	0	1134		1134	Compression		
A-2	L End	11.63	0.00	1	1256	1256		0	Not required	5645	0.00
A-2	L End	11.63	0.00	1	1262	2085		3347	Compression	10312	0.32
	V Elem	12.63	0.00	1	1088	2052		3140	Compression		
	V Elem	29.38	0.00	1	1088	753		335	Refer to upper level		
	V Elem	29.38	0.00	1	1088	1256		2344	Compression		
	V Elem	35.88	0.00	1	0	338		337	Compression		
A-2	R End	58.38	0.00	1	1262	1262		0	Not required	5645	0.00
A-2	R End	58.38	0.00	1	1256	2111		3367	Compression	10312	0.33
A-3	L End	72.63	0.00	1	2366	535		1831	HDU5-SDS	5645	0.32
A-3	L End	72.63	0.00	1	2372	891		3263	Compression	10312	0.32
A-3	R End	88.88	0.00	1	2372	535		1838	HDU5-SDS	5645	0.33
A-3	R End	88.88	0.00	1	2366	891		3257	Compression	10312	0.32
Line C											
C-1	L Op 1	1.88	33.00	1	0	270		270	Compression	10312	0.03
C-1	L End	4.62	33.00	1	1378	7621		8999	Compression	10312	0.87
C-1	t @ Op 6	23.13	33.00	1	100			100	HDU5-SDS	5645	0.02
C-1	t @ Op 6	25.88	33.00	1	100			100	HDU5-SDS	5645	0.02
	V Elem	38.13	33.00	1	732	732		0	Refer to upper level		
	V Elem	38.13	33.00	1	732	1823		2554	Compression		
C-1	R End	88.88	33.00	1	647	647		0	Not required	5645	0.00
C-1	R End	88.88	33.00	1	645	4563		5208	Compression	10312	0.51
Level 4											
Line-Wall	Posit'n	Location [ft]		Load Case	Tensile Hold-down or Compressive Stud Force [lbs]				Hold-down	Cap [lbs]	Crit Resp.
		X	Y		Shear	Dead	Uplift	Cmb'd			
Line 1											
1-1	L End	0.00	0.12	2	80	80		0	Not required	5645	0.00
1-1	L End	0.00	0.12	2	466	162		628	Compression	10312	0.06
1-1	L Op 1	0.00	2.88	2	466	413		53	HDU5-SDS	5645	0.01
1-1	L Op 1	0.00	2.88	2	80	660		740	Compression	10312	0.07
1-1	R Op 1	0.00	12.88	2	2295	551		1744	HDU5-SDS	5645	0.31
1-1	R Op 1	0.00	12.88	2	2002	918		2920	Compression	10312	0.28
1-1	L Op 2	0.00	19.88	2	2002	551		1451	HDU5-SDS	5645	0.26
1-1	L Op 2	0.00	19.88	2	2295	918		3213	Compression	10312	0.31
1-1	R Op 2	0.00	29.88	2	436	421		15	HDU5-SDS	5645	0.00
1-1	R Op 2	0.00	29.88	2	703	702		1404	Compression	10312	0.14
1-1	R End	0.00	32.88	2	703	105		597	HDU5-SDS	5645	0.11
1-1	R End	0.00	32.88	2	436	176		612	Compression	10312	0.06
Line 2											

WoodWorks® Shearwalls

Hold-Down and Compression Design (flexible wind design, continued)

2-1	L End	38.25	0.12	2	1092	608	485	HDU5-SDS	5645	0.09
2-1	L End	38.25	0.12	2	1080	1012	2093	Compression	10312	0.20
2-1	R End	38.25	18.63	2	1080	680	400	HDU5-SDS	5645	0.07
2-1	R End	38.25	18.63	2	1092	1134	2226	Compression	10312	0.22
2-2	R Op 1	38.25	21.13	1	0	122	121	Compression		-
Line A										
	V Elem	1.88	0.00	1	0	567	567	Compression		
A-2	L End	12.63	0.00	1	1088	891	197	HDU5-SDS	5645	0.03
A-2	L End	12.63	0.00	1	1088	1485	2573	Compression	10312	0.25
A-2	R End	29.38	0.00	1	1088	753	335	HDU5-SDS	5645	0.06
A-2	R End	29.38	0.00	1	1088	1256	2344	Compression	10312	0.23
A-2	R Op 2	35.88	0.00	1	0	338	337	Compression	10312	0.03
Line C										
C-1	L Op 1	1.88	33.00	1	0	135	135	Compression	10312	0.01
C-1	L End	4.62	33.00	1	732	1958	2689	Compression	10312	0.26
C-1	R End	38.13	33.00	1	732	732	0	Not required	5645	0.00
C-1	R End	38.13	33.00	1	732	1823	2554	Compression	10312	0.25

Legend:

Line-Wall:

At wall or opening – Shearline and wall number

At vertical element – Shearline

Posit'n – Position of stud pack that hold-down is attached to or which is applying compression force:

V Elem – Vertical element: column or strengthened studs required where not at wall end or opening

L or R End – At left or right wall end

L or R Op n – At left or right side of opening n

t @ Op n – Uplift force t at opening n from offset opening in perforated wall above, from SDPWS 4.3.6.4.2.1

Location – Co-ordinates in Plan View

Load Case – Results are for critical load case:

ASCE 7 All Heights: Case 1 or 2 from Fig. 27.3-8

ASCE 7 Low-rise: Windward corner(s) and Case A or B from Fig. 28.3-1

ASCE 7 Minimum loads (27.1.5 / 28.3.4): "Min"

Tensile Hold-down or Compressive Stud Force – Upwards force on hold-down at one end of the wall or downward force on bottom plate under studs at the other end, for each force direction. Includes forces transferred from upper levels.

Shear – Overturning component = $V \times h / beff$ from SDPWS Eqn. 4.3-7; V = force on segment, ASD-factored by 0.60; h = wall height, beff = wall segment length – (tension stud pack width + hold-down anchor bolt offset) – (1/2 compression stud pack width). For perforated walls = $V \times h / Co$ sum (bi) from SDPWS Eqn. 4.3-8.

Dead – Dead load resisting component, factored for ASD by 0.60 for tension and 1.0 for compression

Uplift – Uplift wind load component, factored for ASD by 0.60

Cmb'd – Sum of ASD-factored overturning, dead and uplift forces. May also include the uplift force t from perforated walls from SDPWS

4.3.6.4.2.1 when openings are staggered.

Hold-down – Device model number from hold-down database; "Compression" for bearing of end stud pack on bottom plate

Cap – Hold-downs: Allowable ASD tension load from database; Compression: allowable ASD bearing force = $Ct CM Cb Fcp A$; A = cross sectional area of end studs. Refer to Framing materials table for details

Crit. Resp. – Critical Response = Combined ASD force / Allowable ASD tension load

Notes:

HDU5-SDS2.5 for studs with thickness > 0'-3" and depth > 0'-3.5" : Uses 14 1/4" x 2.5" SDS heavy-duty screws; 5/8" anchor bolt.

Refer to the Shear Line Dimensions table for wall height h, effective segment length beff and perforated wall adjusted sum of bi, to the Story Table for joist depth, and to the Shear Results table for perforated factor Co.

Most severe of wind load cases is used for overturning calculation.

Designer is responsible for design of connection from wall to floor or foundation for shear force shown in Shear Results table. Refer to SDPWS 4.3.6.4.3 for foundation anchor bolt requirements.

***WARNING - Design capacity has been exceeded.**

WoodWorks® Shearwalls

COLLECTOR FORCES (flexible wind design)

Level 1					Drag Strut Force [lbs]		Strap/Blocking Force [lbs]	
Line-Wall	Position on Wall or Opening	Location [ft]		Load Case	-->	<---	-->	<---
		X	Y					
Line 1								
1-1	Right Wall End	0.00	7.50		4652	-3568		
1-3	Left Wall End	0.00	25.50		-3338	4412		
Line 2								
2-1	Right Wall End	38.25	19.00		5932	-5926		
Line 3								
3-1	Right Opening 1	47.00	5.00		-1820	1818		
3-1	Right Wall End	47.00	19.00		5097	-5090		
Line 6								
6-1	Right Wall End	89.00	7.50		4224	-2597		
6-3	Left Wall End	89.00	25.50		-2597	4215		
Line A								
A-2	Left Wall End	16.25	0.00		-2071	2074		
A-2	Right Wall End	38.00	0.00		3648	-3730		
A-3	Right Opening 2	51.25	0.00		1960	-2039		
A-3	Left Opening 3	63.75	0.00		3217	-3223		
Line C								
C-1	Right Wall End	29.00	33.00		4165	-4151		
C-2	Right Opening 1	35.75	33.00		3401	-3386		
C-2	Left Opening 2	48.25	33.00		2899	-2890		
C-2	Right Opening 3	56.25	33.00		1993	-1983		
C-2	Left Opening 4	71.75	33.00		1230	-1226		
C-2	Right Opening 4	74.50	33.00		918	-915		
C-2	Left Opening 5	79.25	33.00		674	-672		
C-2	Right Opening 5	82.00	33.00		363	-360		
Level 2								
Line-Wall	Position on Wall or Opening	Location [ft]		Load Case	-->	<---	-->	<---
		X	Y					
Line 1								
1-1	Left Opening 1	0.00	3.00		-568	-597		
1-1	Right Opening 1	0.00	12.75		-3515	2345		
1-1	Left Opening 2	0.00	20.00		1914	-2167		
1-1	Right Opening 2	0.00	29.75		-1033	774		
Line 2								
2-1	Right Wall End	38.25	19.00		3971	-3964		
Line 3								
3-1	Right Opening 1	47.00	5.00		-1064	1061		
3-1	Right Wall End	47.00	19.00		2979	-2972		
Line 6								
6-1	Left Opening 1	89.00	7.75		692	-690		
6-1	Right Opening 1	89.00	10.25		-159	159		
6-1	Left Opening 2	89.00	14.75		365	-365		
6-1	Right Opening 2	89.00	17.00		-430	429		
6-1	Left Opening 3	89.00	22.75		159	-159		
6-1	Right Opening 3	89.00	25.25		-692	690		
Line A								
A-2	Left Wall End	11.50	0.00		-1025	1028		
A-2	Left Opening 1	18.50	0.00		891	-893		
A-2	Right Opening 1	23.25	0.00		468	-469		
A-2	Left Opening 2	31.50	0.00		1832	-1837		
A-2	Right Opening 2	34.00	0.00		1609	-1613		
A-2	Left Opening 3	41.25	0.00		2669	-2675		
A-2	Right Opening 3	44.25	0.00		2401	-2407		
A-2	Left Opening 4	48.25	0.00		2986	-2993		
A-2	Right Opening 5	55.75	0.00		2317	-2322		
A-2	Right Wall End	58.50	0.00		2719	-2725		
Line C								
C-1	Right Opening 1	4.50	33.00		-350	350		
C-1	Left Opening 2	12.50	33.00		-144	144		
C-1	Right Opening 2	14.75	33.00		-319	319		
C-1	Left Opening 3	18.75	33.00		-216	216		
C-1	Right Opening 3	21.00	33.00		-391	391		
C-1	Left Opening 4	31.25	33.00		-127	128		
C-1	Right Opening 4	33.75	33.00		-322	322		
C-1	Left Opening 5	57.50	33.00		612	-613		
C-1	Right Opening 5	63.25	33.00		165	-166		
C-1	Left Opening 6	70.00	33.00		339	-339		
C-1	Right Opening 6	72.25	33.00		164	-164		
C-1	Left Opening 7	77.50	33.00		299	-299		

WoodWorks® Shearwalls

COLLECTOR FORCES (flexible wind design, continued)

C-1 Right Opening 7		83.25	33.00		-226	226		
Level 3					Drag Strut Force [lbs]		Strap/Blocking Force [lbs]	
Line-Wall	Position on Wall or Opening	Location [ft]		Load Case	--->	<---	--->	<---
		X	Y					
Level 3								
Line 1								
1-1	Left Opening 1	0.00	3.00		764	438		
1-1	Right Opening 1	0.00	12.75		-997	2193		
1-1	Left Opening 2	0.00	20.00		2224	-2339		
1-1	Right Opening 2	0.00	29.75		464			
Line 2								
2-1	Right Wall End	38.25	19.00		2286	-2278		
Line 3								
3-1	Right Opening 1	47.00	5.00		-414	411		
3-1	Right Wall End	47.00	19.00		1160	-1151		
Line 6								
6-1	Left Opening 1	89.00	7.75		278	-276		
6-1	Right Opening 1	89.00	10.25		-64	64		
6-1	Left Opening 2	89.00	14.75		147	-146		
6-1	Right Opening 2	89.00	17.00		-173	172		
6-1	Left Opening 3	89.00	22.75		64	-64		
6-1	Right Opening 3	89.00	25.25		-278	276		
Line A								
A-2	Left Wall End	11.50	0.00		-590	592		
A-2	Left Opening 1	18.50	0.00		-336	337		
A-2	Right Opening 1	23.25	0.00		-580	582		
A-2	Left Opening 2	31.50	0.00		-246	246		
A-2	Right Opening 2	34.00	0.00		-374	374		
A-2	Left Opening 3	41.25	0.00		273	-276		
A-2	Right Opening 3	44.25	0.00		119	-121		
A-2	Left Opening 4	48.25	0.00		264	-267		
A-2	Right Opening 5	55.75	0.00		-260	260		
A-2	Right Wall End	58.50	0.00		-21	19		
A-3	Left Wall End	72.50	0.00		-739	740		
A-3	Left Opening 1	77.00	0.00		-423	423		
A-3	Right Opening 1	79.75	0.00		-564	565		
A-3	Left Opening 2	82.75	0.00		-353	354		
A-3	Right Opening 2	85.50	0.00		-494	496		
Line C								
C-1	Right Opening 1	4.50	33.00		-210	210		
C-1	Left Opening 2	11.25	33.00		-151	151		
C-1	Right Opening 2	13.75	33.00		-268	268		
C-1	Left Opening 3	23.25	33.00		-185	186		
C-1	Right Opening 3	25.75	33.00		-302	302		
C-1	Left Opening 4	57.50	33.00		487	-488		
C-1	Right Opening 4	63.25	33.00		219	-219		
C-1	Left Opening 5	70.00	33.00		277	-278		
C-1	Right Opening 5	72.25	33.00		172	-173		
C-1	Left Opening 6	77.50	33.00		218	-218		
C-1	Right Opening 6	83.25	33.00		-143	143		
Level 4								
Line-Wall	Position on Wall or Opening	Location [ft]		Load Case	Drag Strut Force [lbs]		Strap/Blocking Force [lbs]	
		X	Y		--->	<---	--->	<---
Line 1								
1-1	Left Opening 1	0.00	3.00		-151	35		
1-1	Right Opening 1	0.00	12.75		-718	596		
1-1	Left Opening 2	0.00	20.00		611	-514		
1-1	Right Opening 2	0.00	29.75		44	47		
Line 2								
2-1	Left Opening 1	38.25	11.75		684	-676		
2-1	Right Opening 1	38.25	14.00		553	-547		
2-1	Right Wall End	38.25	18.75		829	-820		
Line A								
A-2	Left Wall End	12.50	0.00		-416	416		
A-2	Left Opening 1	18.50	0.00		95	-95		
A-2	Right Opening 1	23.25	0.00		-241	241		
A-2	Left Opening 2	29.50	0.00		291	-291		
Line C								
C-1	Right Opening 1	4.50	33.00		-146	146		
C-1	Left Opening 2	11.25	33.00		177	-177		
C-1	Right Opening 3	18.75	33.00		-347	347		
C-1	Left Opening 4	29.50	33.00		168	-168		
C-1	Right Opening 4	35.25	33.00		-144	144		

WoodWorks® Shearwalls

COLLECTOR FORCES (flexible wind design, continued)

--	--	--

Legend:

Line-Wall - Shearline and wall number

Position... - Side of opening or wall end that drag strut is attached to

Location - Co-ordinates in Plan View

Load Case - Results are for critical load case:

ASCE 7 All heights Case 1 or 2

ASCE 7 Low-rise corner; Case A or B

Drag strut Force - Axial force in transfer element at openings, gaps, or changes in design shear along shearline. + : tension; - : compression.

Based on ASD-factored shearline force (v_{max} from 4.3.6.4.1.1 for perforated walls)

Strap/Blocking Force – For FTAO walls, force transferred from above and below opening to shearwall pier.

-> Due to shearline force in the west-to-east or south-to-north direction

<- Due to shearline force in the east-to-west or north-to-south direction

WoodWorks® Shearwalls

MWFRS DEFLECTION (flexible wind design)

These deflections are used to determine shearwall stiffness for force distribution

Wall, segment	W Gp	Dir	Srf	v plf	b ft	h ft	Bending A sq.in	Defl in	Ga kips/in	Nail slip Vn lbs	en in	Shear Defl in	Hold Defl in	Total Defl in
Level 1														
Line 1														
1-1	1	S->N	Comb	1064.2	7.50	14.75	16.5	.158	132.1	126	.003	.119	1.60	1.87
		N->S	Comb	919.1	7.50	14.75	16.5	.136	132.1	126	.003	.103	1.59	1.83
1-3	1	S->N	Comb	889.0	7.50	14.75	16.5	.132	132.1	126	.003	.099	1.64	1.87
		N->S	Comb	1031.6	7.50	14.75	16.5	.153	132.1	126	.003	.115	1.56	1.83
Line 2														
2-1	8	S->N	1S	735.9	19.00	14.75	16.5	.043	38.6	149	.017	.281	0.41	0.73
		N->S	1S	735.1	19.00	14.75	16.5	.043	38.6	149	.017	.281	0.36	0.68
Line 3														
3-1,2	8	S->N	1S	858.1	14.00	14.75	16.5	.068	38.6	149	.017	.328	0.97	1.36
		N->S	1S	857.0	14.00	14.75	16.5	.068	38.6	149	.017	.327	1.00	1.39
Line 6														
6-1	1	S->N	Comb	942.0	7.50	14.75	16.5	.140	132.1	126	.003	.105	1.26	1.51
		N->S	Comb	724.7	7.50	14.75	16.5	.107	132.1	126	.003	.081	1.32	1.50
6-3	1	S->N	Comb	725.1	7.50	14.75	16.5	.107	132.1	126	.003	.081	1.32	1.51
		N->S	Comb	940.5	7.50	14.75	16.5	.139	132.1	126	.003	.105	1.26	1.50
Line A														
A-2	1	W->E	Comb	390.4	21.75	14.75	16.5	.020	132.1	126	.003	.044	0.21	0.27
		E->W	Comb	394.5	21.75	14.75	16.5	.020	132.1	126	.003	.044	0.20	0.26
A-3	2	W->E	ExtS	228.0	12.50	14.75	16.5	.020	13.4	183	.031	.251	0.00	0.27
		E->W	ExtS	222.3	12.50	14.75	16.5	.020	13.4	183	.031	.245	0.00	0.26
Line C														
C-1	1	W->E	Comb	256.8	29.00	14.75	16.5	.010	132.1	126	.003	.029	0.11	0.15
		E->W	Comb	256.5	29.00	14.75	16.5	.010	132.1	126	.003	.029	0.11	0.15
C-2	2	W->E	ExtS	73.1	37.70	14.75	16.5	.002	13.4	183	.031	.081	0.06	0.15
		E->W	ExtS	73.6	37.70	14.75	16.5	.002	13.4	183	.031	.081	0.06	0.15
Wall, segment	W Gp	Dir	Srf	v plf	b ft	h ft	Bending A sq.in	Defl in	Ga kips/in	Nail slip Vn lbs	en in	Shear Defl in	Hold Defl in	Total Defl in
Level 2														
Line 1														
1-1,1	5	S->N	Comb	113.0	3.00	9.00	16.5	.010	111.9	165	.008	.009	1.36	1.37
		N->S	Comb	500.5	3.00	9.00	16.5	.042	111.9	165	.008	.040	1.29	1.37
1-1,2		S->N	Comb	1051.1	7.25	9.00	16.5	.037	111.9	165	.008	.085	1.25	1.37
		N->S	Comb	924.0	7.25	9.00	16.5	.032	111.9	165	.008	.074	1.27	1.37
1-1,3		S->N	Comb	620.2	3.25	9.00	16.5	.048	111.9	165	.008	.050	1.27	1.37
		N->S	Comb	540.0	3.25	9.00	16.5	.042	111.9	165	.008	.043	1.29	1.37
Line 2														
2-1	7	S->N	1S	492.7	19.00	9.00	16.5	.007	25.3	171	.025	.175	0.20	0.39
		N->S	1S	491.8	19.00	9.00	16.5	.007	25.3	171	.025	.175	0.02	0.20
Line 3														
3-1,2	7	S->N	1S	501.6	14.00	9.00	16.5	.009	25.3	171	.025	.179	0.35	0.53
		N->S	1S	500.3	14.00	9.00	16.5	.009	25.3	171	.025	.178	0.28	0.47
Line 6														
6-1	9	S->N	ExtS	312.7	25.75	9.00	16.5	.003	19.4	178	.028	.145	0.12	0.27
		N->S	ExtS	312.0	25.75	9.00	16.5	.003	19.4	178	.028	.145	0.12	0.27
Line A														
A-2	3	W->E	ExtS	362.9	27.74	9.00	16.5	.005	38.6	149	.017	.085	0.12	0.21
		E->W	ExtS	363.7	27.74	9.00	16.5	.005	38.6	149	.017	.085	0.12	0.21
A-3	4	Both	ExtS	0.0	9.22	9.00	16.5	-	25.3	-	-	-	-	0.21
Line C														
C-1	2	W->E	ExtS	117.0	63.31	9.00	16.5	.000	13.4	183	.031	.079	0.04	0.12
		E->W	ExtS	117.2	63.31	9.00	16.5	.000	13.4	183	.031	.079	0.04	0.12
Wall, segment	W Gp	Dir	Srf	v plf	b ft	h ft	Bending A sq.in	Defl in	Ga kips/in	Nail slip Vn lbs	en in	Shear Defl in	Hold Defl in	Total Defl in
Level 3														
Line 1														
1-1,1	6	S->N	ExtS	435.2	3.00	9.00	16.5	.037	56.0	165	.008	.070	1.26	1.37
		N->S	ExtS	33.8	3.00	9.00	16.5	.003	56.0	165	.008	.005	0.01	0.02
1-1,2		S->N	ExtS	624.9	7.25	9.00	16.5	.022	56.0	165	.008	.100	0.61	0.73
		N->S	ExtS	804.9	7.25	9.00	16.5	.028	56.0	165	.008	.129	0.67	0.83
1-1,3		S->N	ExtS	37.9	3.25	9.00	16.5	.003	56.0	165	.008	.006	0.01	0.02
		N->S	ExtS	0.0	3.25	9.00	16.5	-	56.0	-	-	-	-	0.83
Line 2														
2-1	7	S->N	1S	283.6	19.00	9.00	16.5	.004	25.3	171	.025	.101	0.16	0.27
		N->S	1S	282.6	19.00	9.00	16.5	.004	25.3	171	.025	.101	0.01	0.11

WoodWorks® Shearwalls

MWFRS DEFLECTION (flexible wind design, continued)

Line	Wall segment	W Gp	Dir	Srf	v plf	b ft	h ft	Bending A sq.in	Defl in	Ga kips/in	Nail slip Vn lbs	en in	Shear Defl in	Hold Defl in	Total Defl in
Line 3	3-1,2	7	S->N	1S	195.3	14.00	9.00	16.5	.004	25.3	171	.025	.070	0.22	0.29
			N->S	1S	193.8	14.00	9.00	16.5	.003	25.3	171	.025	.069	0.21	0.28
Line 6	6-1	2	S->N	ExtS	125.6	25.75	9.00	16.5	.001	13.4	183	.031	.084	0.10	0.19
			N->S	ExtS	124.8	25.75	9.00	16.5	.001	13.4	183	.031	.084	0.10	0.19
Line A	A-2	4	W->E	ExtS	138.3	27.74	9.00	16.5	.001	25.3	171	.025	.049	0.00	0.05
			E->W	ExtS	139.0	27.74	9.00	16.5	.001	25.3	171	.025	.049	0.00	0.05
	A-3	4	W->E	ExtS	256.9	9.22	9.00	16.5	.007	25.3	171	.025	.091	0.33	0.43
			E->W	ExtS	257.6	9.22	9.00	16.5	.007	25.3	171	.025	.092	0.33	0.43
Line C	C-1	2	W->E	ExtS	71.4	65.75	9.00	16.5	.000	13.4	183	.031	.048	0.04	0.09
			E->W	ExtS	71.6	65.75	9.00	16.5	.000	13.4	183	.031	.048	0.04	0.09
					v	b	h	Bending		Ga	Nail slip		Shear	Hold	Total
					plf	ft	ft	A	Defl	kips/	Vn	en	Defl	Defl	Defl
								sq.in	in	in	lbs	in	in	in	in
Level 4															
Line 1															
1-1,1	7		S->N	ExtS	7.9	3.00	9.00	16.5	.001	25.3	171	.025	.003	0.01	0.01
			N->S	ExtS	45.8	3.00	9.00	16.5	.004	25.3	171	.025	.016	0.91	0.93
			S->N	ExtS	241.5	7.25	9.00	16.5	.008	25.3	171	.025	.086	0.42	0.51
			N->S	ExtS	210.7	7.25	9.00	16.5	.007	25.3	171	.025	.075	0.41	0.49
1-1,2			S->N	ExtS	44.7	3.25	9.00	16.5	.003	25.3	171	.025	.016	0.83	0.85
			N->S	ExtS	71.9	3.25	9.00	16.5	.006	25.3	171	.025	.026	0.88	0.91
Line 2	2-1	2	S->N	ExtS	116.3	16.50	9.00	16.5	.002	13.4	183	.031	.078	0.16	0.24
			N->S	ExtS	115.1	16.50	9.00	16.5	.002	13.4	183	.031	.077	0.16	0.24
Line A	A-2	4	Both	ExtS	118.4	12.25	9.00	16.5	.002	25.3	171	.025	.042	0.22	0.26
Line C	C-1	2	Both	ExtS	80.3	19.50	9.00	16.5	.001	13.4	183	.031	.054	0.00	0.06

Legend:

Wall, segment – Wall and segment between openings, e.g. B-3,2 = second segment on Wall 3 on Shearline B.

W Gp – Wall design group, refer to Sheathing and Framing Materials tables.

Dir – Force direction.

Srf – Wall surface = Int(erior) or Ext(erior) for perimeter walls, 1 or 2 for interior partitions; Comb = Combined v and Ga for identical materials on each side; S = Ga from side with stronger shear resistance; W = 2 x Ga of weaker side.

v – ASD shear force per unit distance on wall segment.

Unblocked walls = v / Cub as per SDPWS 4.3.4.3, Cub = Unblocked factor from 4.3.5.3, shown in the Shear Results table.

Perforated walls = v_{max} from Eqn. 4.3-9, as per 4.3.4.2.

FTAO walls = Unit shear force in pier beside opening(s).

b – Wall or segment length.

Segmented wall or FTAO wall segments = Width of wall segment between openings.

Perforated wall = Sum of FHS segments, modified as in 4.3.3.4 per 4.3.4.2.

FTAO wall = Length of wall including openings.

h – Wall height.

FTAO piers = Distance from bottom of opening to top of wall; for end segments, results using that distance and the wall height are averaged.

Defl – Horizontal shear wall deflection due to given term:

Bending = $8vh^3 / EAb$; A = Effective cross sectional area of segment end stud(s), E = stud mod. of elasticity in Framing Materials table

For i studs at one end and j at the other, $A = 2ij / (i + j) \times$ area of one stud, based on Ex. C4.3.4-3

Shear = $vh / 1000 Ga$; Ga = $vw / (vw / Gvtv + 0.75 en)$, from SDPWS Ex. C4.3.4-1.

vw = ASD sheathing capacity.

Gvtv = Shear stiffness from C4.3.4, shown in Sheathing Materials table.

en = Nail slip from Table C4.2.3D of form aVn^b for WSP, varies linearly to value at capacity for other materials.

Vn = Shear force per nail along panel edge at ASD capacity vw.

Hold – Anchorage system (hold-down) = $da \times h / beff$.

da = Vertical hold-down displacement; refer to Hold-down Displacement table for components.

beff = Effective wall segment length = b - (tension stud pack width + hold-down anchor bolt offset) - (1/2 compression stud pack width)

beff is given in the Shear Wall Dimensions table.

For FTAO walls, hold-down device at end of wall is applied to all segments, as per APA T555.

Total Defl – Deflection from bending + shear + hold-down, as per Eqn. 4.3-2.

For FTAO walls, the average of the values for the segments, as per APA T555.

WARNING - On shearline(s) A, 1 the program was unable to equalize deflections on the shearwall segments. Change design setting to capacity-based rigidity, or turn off the distribution to segments based on rigidity.

WoodWorks® Shearwalls

MWFRS HOLD-DOWN DISPLACEMENT (flexible wind design)

These displacements are used to determine deflections for force distribution

Wall, segment	Dir	Hold-down	Tens. force lbs	Vert. Displacement			Slippage		Shrink +Extra in	Comp. force lbs	Crush da in	Total da in	Horz Defl in
				Manuf in	Add in	da in	Vf lbs	da in					
Level 1													
Line 1													
1-1	S->N	HDU5-SDS	21012	.428	.024	0.452	-	-	.156	16903	0.18	0.78	1.60
	N->S	HDU5-SDS	13627	.278	.016	0.293	-	-	.156	20887	0.33	0.78	1.59
1-3	S->N	HDU5-SDS	13166	.268	.015	0.284	-	-	.156	21607	0.37	0.81	1.64
	N->S	HDU5-SDS	20994	.428	.024	0.452	-	-	.156	16405	0.16	0.77	1.56
Line 2													
2-1	S->N	HDU5-SDS	16698	.340	.019	0.360	-	-	.156	0	0.00	0.52	0.41
	N->S	HDU5-SDS	0	.000	.000	0.000	-	-	.000	23255	0.46	0.46	0.36
Line 3													
3-1,2	S->N	HDU5-SDS	17604	.359	.020	0.379	-	-	.156	21566	0.37	0.90	0.97
	N->S	HDU5-SDS	17856	.364	.021	0.385	-	-	.156	22015	0.39	0.93	1.00
Line 6													
6-1	S->N	HDU5-SDS	15843	.323	.018	0.341	-	-	.156	15024	0.12	0.62	1.26
	N->S	HDU5-SDS	10673	.217	.012	0.230	-	-	.156	19276	0.26	0.65	1.32
6-3	S->N	HDU5-SDS	10680	.218	.012	0.230	-	-	.156	19297	0.26	0.65	1.32
	N->S	HDU5-SDS	15806	.322	.018	0.340	-	-	.156	15001	0.12	0.62	1.26
Line A													
A-2	W->E	HDU5-SDS	5937	.121	.007	0.128	-	-	.156	6997	0.02	0.30	0.21
	E->W	HDU5-SDS	5484	.112	.006	0.118	-	-	.156	6544	0.02	0.29	0.20
A-3	W->E	HDU5-SDS	0	.000	.000	0.000	-	-	.000	251	0.00	0.00	0.00
	E->W	HDU5-SDS	0	.000	.000	0.000	-	-	.000	152	0.00	0.00	0.00
Line C													
C-1	W->E	HDU5-SDS	1906	.039	.002	0.041	-	-	.156	6271	0.02	0.21	0.11
	E->W	HDU5-SDS	907	.018	.001	0.020	-	-	.156	10086	0.04	0.21	0.11
C-2	W->E	HDU5-SDS	247	.006	.000	0.006	-	-	.156	-176	0.00	0.16	0.06
	E->W	HDU5-SDS	176	.004	.000	0.004	-	-	.156	-247	0.00	0.16	0.06
Wall, segment	Dir	Hold-down	Tens. force lbs	Manuf in	Add in	da in	Vf lbs	da in	Shrink +Extra in	Comp. force lbs	Crush da in	Total da in	Horz Defl in
Level 2													
Line 1													
1-1,1	S->N	HDU5-SDS	5171	.105	.013	0.118	-	-	.276	7529	0.02	0.41	1.36
	N->S	HDU5-SDS	4473	.091	.011	0.102	-	-	.276	6199	0.02	0.39	1.29
1-1,2	S->N	HDU5-SDS	16265	.331	.041	0.372	-	-	.276	20671	0.32	0.97	1.25
	N->S	HDU5-SDS	16465	.335	.041	0.377	-	-	.276	20872	0.33	0.98	1.27
1-1,3	S->N	HDU5-SDS	5589	.114	.014	0.128	-	-	.276	7379	0.02	0.42	1.27
	N->S	HDU5-SDS	5651	.115	.014	0.129	-	-	.276	8073	0.02	0.43	1.29
Line 2													
2-1	S->N	HDU5-SDS	6539	.133	.016	0.150	-	-	.276	0	0.00	0.43	0.20
	N->S	HDU5-SDS	0	.000	.000	0.000	-	-	.000	10865	0.05	0.05	0.02
Line 3													
3-1,2	S->N	HDU5-SDS	5468	.223	.010	0.233	-	-	.276	7646	0.02	0.53	0.35
	N->S	HDU5-SDS	5605	.114	.014	0.128	-	-	.276	7891	0.02	0.43	0.28
Line 6													
6-1	S->N	HDU5-SDS	1867	.038	.005	0.043	-	-	.276	7569	0.02	0.34	0.12
	N->S	HDU5-SDS	1853	.038	.005	0.042	-	-	.276	7555	0.02	0.34	0.12
Line A													
A-2	W->E	HDU5-SDS	1430	.058	.003	0.061	-	-	.276	9772	0.04	0.37	0.12
	E->W	HDU5-SDS	1430	.058	.003	0.061	-	-	.276	6416	0.02	0.35	0.12
A-3	Both	HDU5-SDS	0	.000	.000	0.000	-	-	.000	0	0.00	0.00	-
Line C													
C-1	Both	HDU5-SDS	89	.002	.000	0.002	-	-	.276	-89	0.00	0.28	0.04
Wall, segment	Dir	Hold-down	Tens. force lbs	Manuf in	Add in	da in	Vf lbs	da in	Shrink +Extra in	Comp. force lbs	Crush da in	Total da in	Horz Defl in
Level 3													
Line 1													
1-1,1	S->N	HDU5-SDS	4159	.085	.010	0.095	-	-	.276	5731	0.02	0.39	1.26
	N->S	HDU5-SDS	0	.000	.000	0.000	-	-	.000	1075	0.00	0.00	0.01
1-1,2	S->N	HDU5-SDS	7018	.143	.018	0.161	-	-	.276	9955	0.04	0.47	0.61
	N->S	HDU5-SDS	8403	.171	.021	0.192	-	-	.276	11341	0.05	0.52	0.67
1-1,3	S->N	HDU5-SDS	0	.000	.000	0.000	-	-	.000	1095	0.00	0.00	0.01
	N->S	HDU5-SDS	0	.000	.000	0.000	-	-	.000	0	0.00	0.00	-
Line 2													
2-1	S->N	HDU5-SDS	2558	.052	.006	0.059	-	-	.276	0	0.00	0.33	0.16
	N->S	HDU5-SDS	0	.000	.000	0.000	-	-	.000	5525	0.01	0.01	0.01
Line 3													

WoodWorks® Shearwalls

MWFRS HOLD-DOWN DISPLACEMENT (flexible wind design, continued)

Wall, segment	Dir	Hold-down	Tens. force lbs	Vert. Displacement Manuf in	da in	da in	Slippage Vf lbs	da in	Shrink +Extra in	Comp. force lbs	Crush da in	Total da in	Horz Defl in
3-1, 2	S->N	HDU5-SDS	1330	.054	.002	0.057	-	-	.276	2419	0.01	0.34	0.22
	N->S	HDU5-SDS	1398	.028	.004	0.032	-	-	.276	2541	0.01	0.31	0.21
Line 6													
6-1	S->N	HDU5-SDS	94	.002	.000	0.002	-	-	.276	2946	0.01	0.29	0.10
	N->S	HDU5-SDS	87	.002	.000	0.002	-	-	.276	2938	0.01	0.29	0.10
Line A													
A-2	W->E	HDU5-SDS	0	.000	.000	0.000	-	-	.000	3367	0.01	0.01	0.00
	E->W	HDU5-SDS	0	.000	.000	0.000	-	-	.000	3347	0.01	0.01	0.00
A-3	W->E	HDU5-SDS	1831	.037	.005	0.042	-	-	.276	3257	0.01	0.33	0.33
	E->W	HDU5-SDS	1838	.037	.005	0.042	-	-	.276	3263	0.01	0.33	0.33
Line C													
C-1	Both	HDU5-SDS	100	.002	.000	0.002	-	-	.276	-100	0.00	0.28	0.04

Legend:

Wall, segment – Wall and segment between openings, e.g. B-3,2 = second segment on Wall 3 on Shearline B

Dir – Force direction

Tens., Comp. – Accumulated ASD hold-down tension force T and end stud compression force C from overturning, dead and wind uplift loads.

da – Vertical displacements due to the following components:

Vert. Displacement – Elongation when slippage calculated separately; displacement when combined elongation/slippage used

Manuf – Using manufacturer's value for anchor bolt length, or no bolt contribution for connector-only elongation

Unless marked with * = (ASD tension force / ASD hold-down capacity) x max ASD elongation or displacement

* - Maximum strength-level elongation or displacement is used. May result in higher than actual displacements for lightly loaded hold-downs, causing the segment to draw less force due to lower than actual stiffness.

Add – Due to longer anchor bolt length than manufacturer's value, or entire bolt length for connector-only elongation = $TL / (Ab \times Es)$

Ab = bolt cross-sectional area

Es = steel modulus = 29000000 psi

L = Lb – Lh

Lb = Total bolt length shown in Storey Information table

Lh = Manufacturer's anchor bolt length for given displacement/elongation from hold-down database

Slippage – Due to vertical slippage of hold-down fasteners attached to stud(s) when not combined with elongation

Nails = en from SDPWS Table C4.2.3D using values for wood structural panels

Bolts = $Vf / (270,000 D^{1.5})$ (NDS 11.3.6); D = bolt diameter, Vf = Tension force T / number of fasteners

Shrink + Extra – Wood shrinkage plus extra displacement due to mis-cuts, gaps, etc.

Shrinkage = $0.002 \times (15\% \text{ fabrication} - 10\% \text{ in-service moisture contents}) \times Ls$

Ls = Length between anchor bolt fasteners subject to perp-to-grain shrinkage; see Story Information table

Crush – Deformation of bottom plate at compression end of wall segment

= $0.02'' \times [r / 0.73, r < 0.73; (1 + (r - 0.73) / 0.27), 0.73 < r < 1; 2r^3, r > 1]$

r = fcp / Fcp' ; $Fcp' = Ct CM Fcp$; $fcp = C / A$, A = cross sectional area of end studs

Total da – Vert. Displacement + Slippage + Shrink + Crush + Extra

Horz Defl – Anchorage deflection term in SDPWS Eqn. C.4.3.4-1 = $h / beff \times da$

h = Wall height. For end segments in FTAO walls, h is the average of the wall height and the distance from the bottom of opening to top of wall

beff = Effective wall segment length = b - (tension stud pack width + hold-down anchor bolt offset) - (1/2 compression stud pack width)

h and b are shown in Deflection table, beff in the Shear Wall Dimensions table

WoodWorks® Shearwalls

Flexible Diaphragm Seismic Design

SEISMIC INFORMATION

Level	Mass [lbs]	Area [sq.ft]	Story Shear Fx [lbs]		Shear Resistance [lbs]		Diaphragm Force [lbs]			
			E-W	N-S	E-W	N-S	E-W		N-S	
							Fpx	Design	Fpx	Design
4	31815	1262.3	5362	5362	9290	10571	5362	5362	5362	5362
3	98091	2877.5	13417	13417	28922	31365	14374	14374	14374	14374
2	73853	2877.5	7234	7234	32633	43258	10822	10822	10822	10822
1	83797	2937.0	4954	4954	67343	53428	12279	12279	12279	12279
All	287555	-	30967	30967	-	-	-	-	-	-

Legend:

Mass – Sum of all generated and input building masses on level = w_x in ASCE 7 Eqn. 12.8-12.

Story Shear – Total ASD-factored shear force induced at level x from Eqn. 12.8-11.

Shear Resistance – Lateral design strength of all shear-resisting elements on story, for use in weak story evaluation (4.1.8).

Diaphragm Force – used by Shearwalls only for drag strut forces, as per Exception to 12.10.2.1.

Fpx - Minimum ASD-factored force for diaphragm design from Eqns. 12.10-1, -2, and -3.

Design = The greater of the story shear and F_{px} + transfer forces from discontinuous shearlines, factored by overstrength (ω) as per 12.10.1.1. $\omega = 2.5$ as per 12.2-1.

Redundancy Factor ρ (rho):

E-W 1.00, N-S 1.00

Automatically calculated according to ASCE 7 12.3.4.2.

Vertical Earthquake Load E_v

$E_v = 0.2 S_{ds} D$; $S_{ds} = 1.00$; $E_v = 0.200 D$ unfactored; $0.140 D$ factored; total dead load factor: $0.6 - 0.140 = 0.460$ tension, $1.0 + 0.140 = 1.140$ compression.

Weak Story (SDPWS 4.1.8)

The lateral resistance of each story is greater than or equal to that of the story above. This vertical distribution of SFRS is permitted.

WoodWorks® Shearwalls

SHEAR RESULTS (flexible seismic design)

N-S Shearlines	W Gp	For Dir	ASD Shear Force [plf]			Asp-Cub		Allowable Shear [plf]					V [lbs]	Resp. Ratio
			v	vmax/vft	V [lbs]	Int	Ext	Int	Ext	Co	C	Cmb		
Line 1														
Level 4														
Ln1, Lev4	-	Both	-	-	2681	-	-	-	-	-	-	-	6269	-
Wall 1-1	7	Both	-	-	2681	-	1.0	-	489	-	-	-	6269	-
Seg. 1	-	S->N	54.0	-	162	-	.88	-	428	-	-	428	1284	0.13
	-	N->S	74.5	-	223	-	.88	-	428	-	-	428	1284	0.17
Seg. 2	-	S->N	322.1	-	2335	-	1.0	-	489	-	-	489	3547	0.66
	-	N->S	322.6	-	2339	-	1.0	-	489	-	-	489	3547	0.66
Seg. 3	-	S->N	56.7	-	184	-	.90	-	442	-	-	442	1437	0.13
	-	N->S	36.6	-	119	-	.90	-	442	-	-	442	1437	0.08
Level 3														
Ln1, Lev3	-	Both	-	-	5029	-	-	-	-	-	-	-	9072	-
Wall 1-1	6	Both	-	-	5029	1.0	1.0	0	708	-	S	-	9072	-
Seg. 1	-	S->N	36.1	-	108	.88	.88	0	620	-	-	620	1859	0.06
	-	N->S	65.0	-	195	.88	.88	0	620	-	-	620	1859	0.10
Seg. 2	-	S->N	617.0	-	4474	1.0	1.0	0	708	-	-	708	5134	0.87
	-	N->S	616.5	-	4470	1.0	1.0	0	708	-	-	708	5134	0.87
Seg. 3	-	S->N	137.4	-	447	.90	.90	0	640	-	-	640	2080	0.21
	-	N->S	111.9	-	364	.90	.90	0	640	-	-	640	2080	0.17
Level 2														
Ln1, Lev2	-	Both	-	-	6710	-	-	-	-	-	-	-	18144	-
Wall 1-1	5	Both	-	-	6710	1.0	1.0	708	708	-	A	-	18144	-
Seg. 1	-	S->N	405.6	-	1217	.88	.88	620	620	-	-	1239	3717	0.33
	-	N->S	454.4	-	1363	.88	.88	620	620	-	-	1239	3717	0.37
Seg. 2	-	S->N	535.0	-	3879	1.0	1.0	708	708	-	-	1416	10267	0.38
	-	N->S	539.6	-	3912	1.0	1.0	708	708	-	-	1416	10267	0.38
Seg. 3	-	S->N	496.6	-	1614	.90	.90	640	640	-	-	1280	4160	0.39
	-	N->S	441.3	-	1434	.90	.90	640	640	-	-	1280	4160	0.34
Level 1														
Ln1, Lev1	-	Both	-	-	7870	-	-	-	-	-	-	-	16166	-
Wall 1-1	1	S->N	607.4	-	4555	1.0	1.0	539	539	-	A	1078	8083	0.56
	1	N->S	473.7	-	3553	1.0	1.0	539	539	-	A	1078	8083	0.44
Wall 1-3	1	S->N	441.9	-	3314	1.0	1.0	539	539	-	A	1078	8083	0.41
	1	N->S	575.6	-	4317	1.0	1.0	539	539	-	A	1078	8083	0.53
Line 2														
Level 4														
Ln2, Lev4	2	Both	162.5	162.5	2681	1.0	1.0	0	261	1.00	S	261	4302	0.62
Level 3														
Ln2, Lev3	-	Both	-	-	5638	-	-	-	-	-	-	-	9296	-
Wall 2-1	7	Both	296.7	-	5638	-	1.0	-	489	-	-	489	9296	0.61
Level 2														
Ln2, Lev2	-	Both	-	-	7442	-	-	-	-	-	-	-	9296	-
Wall 2-1	7	Both	391.7	-	7442	-	1.0	-	489	-	-	489	9296	0.80
Level 1														
Ln2, Lev1	-	Both	-	-	8659	-	-	-	-	-	-	-	12146	-
Wall 2-1	8	Both	455.7	-	8659	-	1.0	-	639	-	-	639	12146	0.71
Line 3														
Level 3														
Ln3, Lev3	-	Both	-	-	4353	-	-	-	-	-	-	-	6850	-
Wall 3-1	7	Both	-	-	4353	-	1.0	-	489	-	-	-	6850	-
Seg. 1	-	Both	0.0	-	0	-	1.0	-	489	-	-	489	-	-
Seg. 2	-	Both	310.9	-	4353	-	1.0	-	489	-	-	489	6850	0.64
Level 2														
Ln3, Lev2	-	Both	-	-	6289	-	-	-	-	-	-	-	6850	-
Wall 3-1	7^	Both	-	-	6289	-	1.0	-	489	-	-	-	6850	-
Seg. 1	-	Both	0.0	-	0	-	1.0	-	489	-	-	489	-	-
Seg. 2	-	Both	449.2	-	6289	-	1.0	-	489	-	-	489	6850	0.92
Level 1														
Ln3, Lev1	-	Both	-	-	7608	-	-	-	-	-	-	-	8950	-
Wall 3-1	8	Both	-	-	7608	-	1.0	-	639	-	-	-	8950	-
Seg. 1	-	Both	0.0	-	0	-	1.0	-	639	-	-	639	-	-
Seg. 2	-	Both	543.4	-	7608	-	1.0	-	639	-	-	639	8950	0.85
Line 6														
Level 3														
Ln6, Lev3	2	Both	146.0	159.5	3760	1.0	1.0	0	239	0.92	S	239	6147	0.61
Level 2														
Ln6, Lev2	9^	Both	216.4	236.4	5573	1.0	1.0	0	348	0.92	S	348	8968	0.62
Level 1														
Ln6, Lev1	-	Both	-	-	6831	-	-	-	-	-	-	-	16166	-
Wall 6-1	1	S->N	560.3	-	4202	1.0	1.0	539	539	-	A	1078	8083	0.52
	1	N->S	350.5	-	2629	1.0	1.0	539	539	-	A	1078	8083	0.33

WoodWorks® Shearwalls

SHEAR RESULTS (flexible seismic design, continued)

Wall 6-3	1	S->N	350.5	-	2629	1.0	1.0	539	539	-	A	1078	8083	0.33
	1	N->S	560.3	-	4202	1.0	1.0	539	539	-	A	1078	8083	0.52
E-W Shearlines	W Gp	For Dir	ASD Shear Force [plf]			Asp-Cub			Allowable Shear [plf]				Resp. Ratio	
			v	vmax/vft	V [lbs]	Int	Ext	Int	Ext	Co	C	Cmb		V [lbs]
Line A														
Level 4														
LnA, Lev4	4	Both	219.2	249.8	2685	1.0	1.0	0	429	0.88	S	429	5259	0.51
Level 3														
LnA, Lev3	-	Both	-	-	9405	-	-	-	-	-	-	-	13784	-
Wall A-2	4	W->E	303.2	411.9	8868	.95	.95	0	360	0.78	S	360	10535	0.84
	4^	E->W	303.2	411.9	8870	.95	.95	0	360	0.78	S	360	10535	0.84
Wall A-3	4	W->E	52.3	86.6	575	.84	.84	0	295	0.72	S	295	3249	0.18
	4	E->W	52.1	86.4	574	.84	.84	0	295	0.72	S	295	3249	0.18
Level 2														
LnA, Lev2	-	Both	-	-	13075	-	-	-	-	-	-	-	17226	-
Wall A-2	3	W->E	404.5	541.1	11830	-	.95	-	478	0.79	-	478	13977	0.85
	3^	E->W	414.5	554.5	12123	-	.95	-	478	0.79	-	478	13977	0.87
Wall A-3	4	W->E	118.0	195.5	1298	.84	.84	0	295	0.72	S	295	3249	0.40
	4	E->W	91.0	150.7	1001	.84	.84	0	295	0.72	S	295	3249	0.31
Level 1														
LnA, Lev1	-	Both	-	-	15615	-	-	-	-	-	-	-	26699	-
Wall A-2	1	W->E	597.7	-	13000	1.0	1.0	539	539	-	A	1078	23440	0.55
	1	E->W	563.5	-	12256	1.0	1.0	539	539	-	A	1078	23440	0.52
Wall A-3	2	W->E	209.3	209.3	2616	1.0	1.0	0	261	1.00	S	261	3259	0.80
	2^	E->W	268.7	268.7	3359	1.0	1.0	0	261	1.00	S	261	3259	1.03*
Line C														
Level 4														
LnC, Lev4	2	Both	130.6	173.1	2677	.95	.95	0	197	0.79	S	197	4031	0.66
Level 3														
LnC, Lev3	2	Both	142.6	161.4	9374	1.0	1.0	0	230	0.88	S	230	15138	0.62
Level 2														
LnC, Lev2	2	Both	202.9	218.9	12938	.99	.99	0	242	0.93	S	242	15407	0.84
Level 1														
LnC, Lev1	-	Both	-	-	15352	-	-	-	-	-	-	-	40644	-
Wall C-1	1	W->E	385.0	-	11166	1.0	1.0	539	539	-	A	1078	31254	0.36
	1	E->W	364.2	-	10561	1.0	1.0	539	539	-	A	1078	31254	0.34
Wall C-2	2	W->E	105.3	116.2	4187	.95	.95	0	236	0.96	S	236	9390	0.45
	2	E->W	120.5	133.0	4791	.95	.95	0	236	0.96	S	236	9390	0.51

Legend:

W Gp - Wall design group defined in Sheathing and Framing Materials tables, where it shows associated Standard Wall. "^" means that this wall is critical for all walls in the Standard Wall group.

For Dir - Direction of seismic force along shearline.

v - Design shear force on segment = ASD-factored shear force per unit length of full-height sheathing (FHS)

vmax/vft - Perforated walls: Collector and in-plane anchorage force as per SDPWS eqn. 4.3-9 = V/FHS/Co. FHS is factored for narrow segments as per 4.3.3.4

FTAO walls: Shear force in piers above and below either openings or piers beside opening(s). Aspect ratio factor does not apply to these piers.

V - ASD factored shear force. For shearline: total shearline force. For wall: total of all segments on wall. For segment: force on segment

Asp/Cub - Unblocked wood structural panel factor Cub from SDPWS 4.3.5.3 or Aspect Ratio factor from 4.3.3.2, which for perforated walls is sum b_i / FHS from 4.3.5.6 with b_i defined in 4.3.3.4. For multi-segment walls, wall row shows Cub and segment rows show Asp. For single-segment walls and perforated walls, value shown is Asp for blocked walls and Cub for unblocked walls.

Int, Ext - Nominal unit shear capacity of interior and exterior sheathing, factored by Table 4.3-1 Note 3 for framing specific gravity and Note 10 for presence of hold-downs. For wall segments, also include unblocked factor Cub and aspect ratio adjustments.

Co - Adjustment factor for perforated walls from SDPWS Equation 4.3-6.

C - Sheathing combination rule, A = Add capacities, S = Strongest side or twice weakest, G = Stiffness-based using Eqns. 4.3-3,-4.

Cmb - Combined interior and exterior unit shear capacity including perforated wall factor Co.

V - Total factored shear capacity of shearline, wall or segment.

Crit Resp - Response ratio = v/Cmb = design shear force/unit shear capacity. "W" indicates that the wind design criterion was critical in selecting wall.

Notes:

Refer to Elevation View diagrams for individual level for uplift anchorage force t for perforated walls given by SDPWS 4.3.6.4.2.1.

The contribution to shear resistance from gypsum, fiberboard, or lumber sheathing is taken as zero because of the Design setting for ignoring contribution was set. Refer to the Sheathing Materials table for the wall groups affected.

***WARNING - Design capacity has been exceeded.**

WoodWorks® Shearwalls

Hold-Down and Compression Design (flexible seismic design)

Level 1		Location [ft]		Tensile Hold-down or Compressive Stud Force [lbs]				Cmb'd	Hold-down	Cap [lbs]	Crit Resp.
Line- Wall	Posit'n	X	Y	Shear	Dead	Ev					
Line 1											
1-1	L End	0.00	0.12	14155	690	161	13626	HDU5-SDS	5645	2.41*	
1-1	L End	0.00	0.12	13085	1150	161	14396	Compression	10312	1.40*	
	V Elem	0.00	2.88	5857	1239	289	4907	Refer to upper level			
	V Elem	0.00	2.88	4887	2066	289	7241	Compression			
1-2	L Op 2	0.00	3.88	0	620	87	706	Compression			
1-1	R End	0.00	7.38	7228	398	93	6923	HDU5-SDS	5645	1.23*	
1-1	R End	0.00	7.38	9268	664	93	10025	Compression	10312	0.97	
	V Elem	0.00	11.13	0	620	87	706	Compression			
	V Elem	0.00	12.88	13799	1792	418	12425	Refer to upper level			
	V Elem	0.00	12.88	13842	2987	418	17247	Compression			
1-3	L End	0.00	25.63	6742	398	93	6437	HDU5-SDS	5645	1.14*	
1-3	L End	0.00	25.63	8782	664	93	9539	Compression	10312	0.93	
	V Elem	0.00	29.13	5948	1560	364	4752	Refer to upper level			
	V Elem	0.00	29.13	5929	2599	364	8892	Compression			
	V Elem	0.00	29.88	6735	1264	295	5767	Refer to upper level			
	V Elem	0.00	29.88	5751	2106	295	8152	Compression			
1-3	R End	0.00	32.88	14534	714	167	13986	HDU5-SDS	5645	2.48*	
1-3	R End	0.00	32.88	13478	1190	167	14835	Compression	10312	1.44*	
Line 2											
2-1	L End	38.25	0.12	14616	2474	577	12719	HDU5-SDS	5645	2.25*	
2-1	L End	38.25	0.12	14616	4124	577	19317	Compression	10312	1.87*	
	V Elem	38.25	18.63	14616	2547	594	12663	Refer to upper level			
	V Elem	38.25	18.63	14616	4245	594	19455	Compression			
	V Elem	38.25	21.13	0	122	17	138	Compression			
Line 3											
	V Elem	47.00	1.88	0	491	69	560	Compression			
3-1	R Op 1	47.00	5.13	15127	1670	390	13846	HDU5-SDS	5645	2.45*	
3-1	R Op 1	47.00	5.13	15127	2784	390	18300	Compression	10312	1.77*	
3-1	R End	47.00	18.88	15127	1376	321	14072	HDU5-SDS	5645	2.49*	
3-1	R End	47.00	18.88	15127	2293	321	17740	Compression	10312	1.72*	
Line 6											
6-1	L End	89.00	0.12	12174	2537	592	10230	HDU5-SDS	5645	1.81*	
6-1	L End	89.00	0.12	8974	4228	592	13794	Compression	10312	1.34*	
6-2	L Op 1	89.00	1.88	0	2567	359	2926	Compression	10312	0.28	
6-1	R End	89.00	7.38	5349	398	93	5056	HDU5-SDS	5645	0.90	
6-1	R End	89.00	7.38	8549	664	93	9293	Compression	10312	0.90	
6	t @ Op 1	89.00	7.50	87	87	87	87	HDU5-SDS	5645	0.02	
6	t @ Op 2	89.00	10.25	891	891	891	891	HDU5-SDS	5645	0.16	
6	t @ Op 2	89.00	14.50	891	891	891	891	HDU5-SDS	5645	0.16	
6	t @ Op 3	89.00	17.00	1138	1138	1138	1138	HDU5-SDS	5645	0.20	
6	t @ Op 3	89.00	22.50	1138	1138	1138	1138	HDU5-SDS	5645	0.20	
6	t @ Op 4	89.00	25.25	87	87	87	87	HDU5-SDS	5645	0.02	
6-3	L End	89.00	25.63	5349	398	93	5056	HDU5-SDS	5645	0.90	
6-3	L End	89.00	25.63	8549	664	93	9293	Compression	10312	0.90	
6-2	R Op 1	89.00	31.13	0	2566	359	2926	Compression			
6-3	R End	89.00	32.88	12174	2537	592	10230	HDU5-SDS	5645	1.81*	
6-3	R End	89.00	32.88	8974	4228	592	13794	Compression	10312	1.34*	
Line A											
	V Elem	1.88	0.00	731	3064	429	4223	Compression			
A	t @ Op 1	11.50	0.00	1558	206	206	1558	HDU5-SDS	5645	0.28	
A	t @ Op 1	12.25	0.00	206	206	206	206	HDU5-SDS	5645	0.04	
	V Elem	12.63	0.00	10225	4989	1164	7722	Refer to upper level			
	V Elem	12.63	0.00	10337	8314	1164	18493	Compression			
A-2	L End	16.38	0.00	8918	1155	269	10411	HDU5-SDS	5645	1.84*	
A-2	L End	16.38	0.00	8408	1925	269	8225	Compression	10312	0.80	
	V Elem	29.38	0.00	2295	753	176	1718	Refer to upper level			
	V Elem	29.38	0.00	2295	1256	176	3726	Compression			
	V Elem	35.88	0.00	0	338	47	385	Compression			
A-2	R End	37.88	0.00	8408	1155	269	8955	HDU5-SDS	5645	1.59*	
A-2	R End	37.88	0.00	8918	1925	269	9681	Compression	10312	0.94	
A	t @ Op 3	41.00	0.00	1363	266	37	1363	HDU5-SDS	5645	0.24	
A	t @ Op 4	44.25	0.00	1603	266	37	1603	HDU5-SDS	5645	0.28	
A	t @ Op 4	48.00	0.00	1603	266	37	1603	HDU5-SDS	5645	0.28	
A-3	L End	51.38	0.00	3150	823	192	2519	HDU5-SDS	5645	0.45	
A-3	L End	51.38	0.00	4045	1372	192	5608	Compression	10312	0.54	
	V Elem	58.38	0.00	8773	3133	731	6370	Refer to upper level			
	V Elem	58.38	0.00	8651	5222	731	14604	Compression			
A-3	R End	63.63	0.00	4045	823	192	3414	HDU5-SDS	5645	0.60	
A-3	R End	63.63	0.00	3150	1372	192	4713	Compression	10312	0.46	
A-3	R Op 6	66.88	0.00	0	266	37	303	Compression	10312	0.03	

WoodWorks® Shearwalls

Hold-Down and Compression Design (flexible seismic design, continued)

	V Elem	69.88	0.00	325	293	68	116	Refer to upper level		
	V Elem	69.88	0.00	273	488	68	813	Compression		
A	t @ Op 1	72.50	0.00	635			635	HDU5-SDS	5645	0.11
	V Elem	73.13	0.00	2273	1095	255	1559	Refer to upper level		
	V Elem	73.13	0.00	1910	1825	255	3866	Compression		
A	t @ Op 1	76.75	0.00	337	266	37	337	HDU5-SDS	5645	0.06
A	t @ Op 2	79.75	0.00	423			423	HDU5-SDS	5645	0.07
A-3	t @ Op 6	80.13	0.00	238	266	37		Compression	10312	0.02
A	t @ Op 2	82.50	0.00	423			423	HDU5-SDS	5645	0.07
A-3	t @ Op 6	82.88	0.00	286	266	37		Compression	10312	0.03
A	t @ Op 3	85.50	0.00	494			494	HDU5-SDS	5645	0.09
A-3	t @ Op 6	86.13	0.00	178	266	37		Compression	10312	0.02
	V Elem	88.88	0.00	2183	1069	249	1857	Refer to upper level		
	V Elem	88.88	0.00	2598	1782	249	4136	Compression		
Line C										
C-1	L End	0.12	33.00	5728	1915	447	4260	HDU5-SDS	5645	0.75
C-1	L End	0.12	33.00	5418	3934	551	9903	Compression	10312	0.96
	V Elem	1.88	33.00	0	405	57	462	Compression		
	V Elem	4.62	33.00	5014	12746	1784	19544	Compression		
	t @ Elem	12.38	33.00	40				Refer to upper level		
	t @ Elem	14.88	33.00	121				Refer to upper level		
	t @ Elem	18.63	33.00	377				Refer to upper level		
	t @ Elem	21.13	33.00	377				Refer to upper level		
	t @ Elem	23.13	33.00	216				Refer to upper level		
	t @ Elem	25.88	33.00	216				Refer to upper level		
C-1	R End	28.88	33.00	5418	1893	442	4234	HDU5-SDS	5645	0.75
C-1	R End	28.88	33.00	5728	2589	362	8413	Compression	10312	0.82
C	t @ Op 4	29.25	33.00	120			120	HDU5-SDS	5645	0.02
C	t @ Op 4	29.50	33.00	141			141	HDU5-SDS	5645	0.02
C	t @ Op 4	31.00	33.00	616			616	HDU5-SDS	5645	0.11
C-2	t @ Op 5	32.62	33.00	97	266	37	97	HDU5-SDS	5645	0.02
C-2	L End	35.88	33.00	1725	2987	697	4297	HDU5-SDS	5645	0.76
C-2	L End	35.88	33.00	1974	6080	851	4043	Compression	10312	0.39
	V Elem	38.13	33.00	1578	1094	255	739	Refer to upper level		
	V Elem	38.13	33.00	1578	1823	255	3655	Compression		
C-2	t @ Op 5	48.13	33.00	1556			1556	HDU5-SDS	5645	0.28
C-2	t @ Op 5	51.38	33.00	571			571	HDU5-SDS	5645	0.10
C-2	t @ Op 5	52.63	33.00	1651			1651	HDU5-SDS	5645	0.29
C-2	t @ Op 5	56.38	33.00	666			666	HDU5-SDS	5645	0.12
C-2	t @ Op 5	71.63	33.00	357			357	HDU5-SDS	5645	0.06
C-2	t @ Op 5	74.62	33.00	499			499	HDU5-SDS	5645	0.09
C-2	R End	88.88	33.00	5411	7058	1647	0	Not required	5645	0.00
C-2	R End	88.88	33.00	5162	13839	1937	20938	Compression	10312	2.03*
Level 2										
Line- Wall	Posit'n	Location [ft]		Tensile Hold-down or Compressive Stud Force [lbs]				Hold-down	Cap [lbs]	Crit Resp.
		X	Y	Shear	Dead	Ev	Cmb'd			
Line 1										
1-1	L End	0.00	0.12	4887	292	68	4663	HDU5-SDS	5645	0.83
1-1	L End	0.00	0.12	5857	486	68	6411	Compression	10312	0.62
1-1	L Op 1	0.00	2.88	5857	1239	289	4907	HDU5-SDS	5645	0.87
1-1	L Op 1	0.00	2.88	4887	2066	289	7241	Compression	10312	0.70
1-1	R Op 1	0.00	12.88	13799	1652	386	12532	HDU5-SDS	5645	2.22*
1-1	R Op 1	0.00	12.88	13842	2754	386	16982	Compression	10312	1.65*
1-1	L Op 2	0.00	19.88	13842	1652	386	12575	HDU5-SDS	5645	2.23*
1-1	L Op 2	0.00	19.88	13799	2754	386	16938	Compression	10312	1.64*
1-1	R Op 2	0.00	29.88	6735	1264	295	5767	HDU5-SDS	5645	1.02*
1-1	R Op 2	0.00	29.88	5751	2106	295	8152	Compression	10312	0.79
1-1	R End	0.00	32.88	5751	316	74	5509	HDU5-SDS	5645	0.98
1-1	R End	0.00	32.88	6735	527	74	7336	Compression	10312	0.71
Line 2										
2-1	L End	38.25	0.12	7804	1634	381	6552	HDU5-SDS	5645	1.16*
2-1	L End	38.25	0.12	7804	2723	381	10908	Compression	10312	1.06*
	V Elem	38.25	18.63	7804	1706	398	6496	Refer to upper level		
	V Elem	38.25	18.63	7804	2844	398	11046	Compression		
	V Elem	38.25	21.13	0	122	17	138	Compression		
Line 3										
	V Elem	47.00	1.88	0	270	38	308	Compression		
3-1	R Op 1	47.00	5.13	6966	918	214	6262	HDU5-SDS	5645	1.11*
3-1	R Op 1	47.00	5.13	6966	1530	214	8710	Compression	10312	0.84
3-1	R End	47.00	18.88	6966	756	176	6386	HDU5-SDS	5645	1.13*
3-1	R End	47.00	18.88	6966	1260	176	8402	Compression	10312	0.81
Line 6										
6-1	L End	89.00	0.12	3625	2138	499	1986	HDU5-SDS	5645	0.35
6-1	L End	89.00	0.12	3625	3564	499	7688	Compression	10312	0.75
6-1	R End	89.00	32.88	3625	2138	499	1986	HDU5-SDS	5645	0.35

WoodWorks® Shearwalls

Hold-Down and Compression Design (flexible seismic design, continued)

6-1	R End	89.00	32.88	3625	3564	499	7688	Compression	10312	0.75	
Line A											
	V Elem	1.88	0.00	312	1923	269	2503	Compression			
A-2	L End	11.63	0.00	4912	1523	355	3744	HDU5-SDS	5645	0.66	
A-2	L End	11.63	0.00	5033	2538	355	7927	Compression	10312	0.77	
	V Elem	12.63	0.00	5722	3035	708	3395	Refer to upper level			
	V Elem	12.63	0.00	5723	5059	708	11490	Compression			
	V Elem	29.38	0.00	2295	753	176	1718	Refer to upper level			
	V Elem	29.38	0.00	2295	1256	176	3726	Compression			
	V Elem	35.88	0.00	0	338	47	385	Compression			
A-2	R End	58.38	0.00	8773	3133	731	6370	HDU5-SDS	5645	1.13*	
A-2	R End	58.38	0.00	8651	5222	731	14604	Compression	10312	1.42*	
A-3	L End	72.63	0.00	2598	1069	249	1778	HDU5-SDS	5645	0.31	
A-3	L End	72.63	0.00	2183	1782	249	4215	Compression	10312	0.41	
A-3	R End	88.88	0.00	2183	1069	249	1364	HDU5-SDS	5645	0.24	
A-3	R End	88.88	0.00	2598	1782	249	4629	Compression	10312	0.45	
Line C											
C-1	L Op 1	1.88	33.00	0	405	57	462	Compression	10312	0.04	
C-1	L End	4.62	33.00	5014	12746	1784	19544	Compression	10312	1.90*	
C-1	t @ Op 7	12.38	33.00	40			40	HDU5-SDS	5645	0.01	
C-1	t @ Op 7	14.88	33.00	121			121	HDU5-SDS	5645	0.02	
C-1	t @ Op 7	18.63	33.00	377			377	HDU5-SDS	5645	0.07	
C-1	t @ Op 7	21.13	33.00	377			377	HDU5-SDS	5645	0.07	
	t @ Elem	23.13	33.00	216				Refer to upper level			
	t @ Elem	25.88	33.00	216				Refer to upper level			
C-1	t @ Op 7	31.13	33.00	202			202	HDU5-SDS	5645	0.04	
C-1	t @ Op 7	33.87	33.00	202			202	HDU5-SDS	5645	0.04	
	V Elem	38.13	33.00	1578	1094	255	739	Refer to upper level			
	V Elem	38.13	33.00	1578	1823	255	3655	Compression			
C-1	R End	88.88	33.00	3437	4483	1046	0	Not required	5645	0.00	
C-1	R End	88.88	33.00	3437	9126	1278	13840	Compression	10312	1.34*	
Level 3											
				Tensile Hold-down							
Line-Wall	Posit'n	Location [ft]		or Compressive Stud Force [lbs]				Hold-down	Cap [lbs]	Crit Resp.	
		X	Y	Shear	Dead	Ev	Cmb'd				
Line 1											
1-1	L End	0.00	0.12	904	194	45	755	HDU5-SDS	5645	0.13	
1-1	L End	0.00	0.12	1396	324	45	1765	Compression	10312	0.17	
1-1	L Op 1	0.00	2.88	1396	826	193	762	HDU5-SDS	5645	0.13	
1-1	L Op 1	0.00	2.88	904	1377	193	2474	Compression	10312	0.24	
1-1	R Op 1	0.00	12.88	8812	1102	257	7967	HDU5-SDS	5645	1.41*	
1-1	R Op 1	0.00	12.88	8812	1836	257	10905	Compression	10312	1.06*	
1-1	L Op 2	0.00	19.88	8812	1102	257	7968	HDU5-SDS	5645	1.41*	
1-1	L Op 2	0.00	19.88	8812	1836	257	10905	Compression	10312	1.06*	
1-1	R Op 2	0.00	29.88	1894	842	197	1248	HDU5-SDS	5645	0.22	
1-1	R Op 2	0.00	29.88	1449	1404	197	3050	Compression	10312	0.30	
1-1	R End	0.00	32.88	1449	211	49	1288	HDU5-SDS	5645	0.23	
1-1	R End	0.00	32.88	1894	351	49	2294	Compression	10312	0.22	
Line 2											
2-1	L End	38.25	0.12	4232	1121	261	3373	HDU5-SDS	5645	0.60	
2-1	L End	38.25	0.12	4232	1867	261	6361	Compression	10312	0.62	
	V Elem	38.25	18.63	4232	1193	278	3317	Refer to upper level			
	V Elem	38.25	18.63	4232	1989	278	6499	Compression			
	V Elem	38.25	21.13	0	122	17	138	Compression			
Line 3											
	V Elem	47.00	1.88	0	135	19	154	Compression			
3-1	R Op 1	47.00	5.13	2849	459	107	2497	HDU5-SDS	5645	0.44	
3-1	R Op 1	47.00	5.13	2849	765	107	3721	Compression	10312	0.36	
3-1	R End	47.00	18.88	2849	378	88	2559	HDU5-SDS	5645	0.45	
3-1	R End	47.00	18.88	2849	630	88	3567	Compression	10312	0.35	
Line 6											
6-1	L End	89.00	0.12	1477	1069	249	657	HDU5-SDS	5645	0.12	
6-1	L End	89.00	0.12	1477	1782	249	3509	Compression	10312	0.34	
6-1	R End	89.00	32.88	1477	1069	249	657	HDU5-SDS	5645	0.12	
6-1	R End	89.00	32.88	1477	1782	249	3509	Compression	10312	0.34	
Line A											
	V Elem	1.88	0.00	0	1134	159	1293	Compression			
A-2	L End	11.63	0.00	3739	1597	373	2514	HDU5-SDS	5645	0.45	
A-2	L End	11.63	0.00	3739	2662	373	6773	Compression	10312	0.66	
	V Elem	12.63	0.00	2295	1231	287	1351	Refer to upper level			
	V Elem	12.63	0.00	2295	2052	287	4634	Compression			
	V Elem	29.38	0.00	2295	753	176	1718	Refer to upper level			
	V Elem	29.38	0.00	2295	1256	176	3726	Compression			
	V Elem	35.88	0.00	0	338	47	385	Compression			
A-2	R End	58.38	0.00	3739	1611	376	2504	HDU5-SDS	5645	0.44	

WoodWorks® Shearwalls

Hold-Down and Compression Design (flexible seismic design, continued)

A-2	R End	58.38	0.00	3739	2684	376	6799	Compression	10312	0.66
A-3	L End	72.63	0.00	797	535	125	387	HDU5-SDS	5645	0.07
A-3	L End	72.63	0.00	795	891	125	1811	Compression	10312	0.18
A-3	R End	88.88	0.00	795	535	125	386	HDU5-SDS	5645	0.07
A-3	R End	88.88	0.00	797	891	125	1813	Compression	10312	0.18
Line C										
C-1	L Op 1	1.88	33.00	0	270	38	308	Compression	10312	0.03
C-1	L End	4.62	33.00	3036	6656	932	10623	Compression	10312	1.03*
C-1	t @ Op 6	23.13	33.00	216			216	HDU5-SDS	5645	0.04
C-1	t @ Op 6	25.88	33.00	216			216	HDU5-SDS	5645	0.04
	V Elem	38.13	33.00	1578	1094	255	739	Refer to upper level		
	V Elem	38.13	33.00	1578	1823	255	3655	Compression		
C-1	R End	88.88	33.00	1459	1902	444	0	Not required	5645	0.00
C-1	R End	88.88	33.00	1459	4563	639	6660	Compression	10312	0.65
Level 4										
Line-Wall	Posit'n	Location [ft]		Tensile Hold-down or Compressive Stud Force [lbs]				Hold-down	Cap [lbs]	Crit Resp.
		X	Y	Shear	Dead	Ev	Cmb'd			
Line 1										
1-1	L End	0.00	0.12	549	97	23	475	HDU5-SDS	5645	0.08
1-1	L End	0.00	0.12	758	162	23	942	Compression	10312	0.09
1-1	L Op 1	0.00	2.88	758	413	96	441	HDU5-SDS	5645	0.08
1-1	L Op 1	0.00	2.88	549	689	96	1334	Compression	10312	0.13
1-1	R Op 1	0.00	12.88	3060	551	129	2638	HDU5-SDS	5645	0.47
1-1	R Op 1	0.00	12.88	3065	918	129	4111	Compression	10312	0.40
1-1	L Op 2	0.00	19.88	3065	551	129	2643	HDU5-SDS	5645	0.47
1-1	L Op 2	0.00	19.88	3060	918	129	4107	Compression	10312	0.40
1-1	R Op 2	0.00	29.88	554	421	98	231	HDU5-SDS	5645	0.04
1-1	R Op 2	0.00	29.88	358	702	98	1158	Compression	10312	0.11
1-1	R End	0.00	32.88	358	105	25	277	HDU5-SDS	5645	0.05
1-1	R End	0.00	32.88	554	176	25	754	Compression	10312	0.07
Line 2										
2-1	L End	38.25	0.12	1526	608	142	1060	HDU5-SDS	5645	0.19
2-1	L End	38.25	0.12	1526	1012	142	2680	Compression	10312	0.26
2-1	R End	38.25	18.63	1526	680	159	1004	HDU5-SDS	5645	0.18
2-1	R End	38.25	18.63	1526	1134	159	2818	Compression	10312	0.27
2-2	R Op 1	38.25	21.13	0	122	17	138	Compression		-
Line A										
	V Elem	1.88	0.00	0	567	79	646	Compression		
A-2	L End	12.63	0.00	2295	891	208	1612	HDU5-SDS	5645	0.29
A-2	L End	12.63	0.00	2295	1485	208	3988	Compression	10312	0.39
A-2	R End	29.38	0.00	2295	753	176	1718	HDU5-SDS	5645	0.30
A-2	R End	29.38	0.00	2295	1256	176	3726	Compression	10312	0.36
A-2	R Op 2	35.88	0.00	0	338	47	385	Compression	10312	0.04
Line C										
C-1	L Op 1	1.88	33.00	0	135	19	154	Compression	10312	0.01
C-1	L End	4.62	33.00	1578	1175	274	677	HDU5-SDS	5645	0.12
C-1	L End	4.62	33.00	1578	1958	274	3809	Compression	10312	0.37
C-1	R End	38.13	33.00	1578	1094	255	739	HDU5-SDS	5645	0.13
C-1	R End	38.13	33.00	1578	1823	255	3655	Compression	10312	0.35

Legend:

Line-Wall:

At wall or opening – Shearline and wall number

At vertical element – Shearline

Posit'n – Position of stud pack that hold-down is attached to:

V Elem – Vertical element: column or strengthened studs required where not at wall end or opening

L or R End – At left or right wall end

L or R Op n – At left or right side of opening n

t @ Op n – Uplift force t at opening n from offset opening in perforated wall above, from SDPWS 4.3.6.4.2.1

Location – Co-ordinates in Plan View

Tensile Hold-down or Compressive Stud Force – Upwards force on hold-down at one end of the wall or downward force on bottom plate under studs at the other end, for each force direction. Includes forces transferred from upper levels.

Shear – Overturning component = $V \times h / beff$ from SDPWS Eqn. 4.3-7; V = force on segment, ASD-factored by 0.70; h = wall height, beff = wall segment length – (tension stud pack width + hold-down anchor bolt offset) – (1/2 compression stud pack width). For perforated walls = $V \times h / Co$ sum (bi) from SDPWS Eqn. 4.3-8.

Dead – Dead load resisting component, factored for ASD by 0.60 for tension and 1.0 for compression

Ev – Vertical seismic load effect from ASCE 7 12.4.2.2 = $-0.2 Sds \times ASD \text{ factor} \times \text{unfactored } D = 0.233 SDS \times \text{factored } D$. Refer to Seismic Information table for more details.

Cmb'd – Sum of ASD-factored overturning, dead and vertical seismic forces. May also include the uplift force t from perforated walls from SDPWS 4.3.6.4.2.1 when openings are staggered.

Hold-down – Device model number from hold-down database; "Compression" for bearing of end stud pack on bottom plate

WoodWorks® Shearwalls

Cap – Hold-downs: Allowable ASD tension load from database; Compression: Allowable ASD bearing force = $C_t C_M C_b F_{cp} A$; A = cross sectional area of end studs. Refer to Framing materials table for details.

Crit. Resp. – Critical Response = Combined ASD force/Allowable ASD tension load

Notes:

HDU5-SDS2.5 for studs with thickness > 0'-3" and depth > 0'-3.5" : Uses 14 1/4" x 2.5" SDS heavy-duty screws; 5/8" anchor bolt.

Combined force from ASCE 7 2.4.1 load combination $10 = - (0.6D - 0.7E_v + 0.7E_h)$; E_h (from 12.4.2.1) = - shear overturning force

Refer to the Shear Line Dimensions table for wall height h , effective segment length b_{eff} and perforated wall adjusted sum of b_i , to the Story Table for joist depth, and to the Shear Results table for perforated factor C_o .

Designer is responsible for design of connection from wall to floor or foundation for shear force shown in Shear Results table. Refer to SDPWS 4.3.6.4.3 for foundation anchor bolt requirements.

***WARNING - Design capacity has been exceeded.**

WoodWorks® Shearwalls

COLLECTOR FORCES (flexible seismic design)

Level 1		Location [ft]		Drag Strut Force [lbs]		Strap/Blocking Force [lbs]	
Line-Wall	Position on Wall or Opening	X	Y	--->	<---	--->	<---
Line 1							
	Shearline force			9585	9585		
1-1	Right Wall End	0.00	7.50	3370	-2149		
1-3	Left Wall End	0.00	25.50	-1858	3079		
Line 2							
2-1	Right Wall End	38.25	19.00	10458	10458		
				4437	-4437		
Line 3							
	Shearline force			9557	9557		
3-1	Right Opening 1	47.00	5.00	-1448	1448		
3-1	Right Wall End	47.00	19.00	4055	-4055		
Line 6							
6-1	Right Wall End	89.00	7.50	8692	8692		
				3371	-1370		
6-3	Left Wall End	89.00	25.50	-1370	3371		
Line A							
	Shearline force			19370	19370		
A-2	Left Wall End	16.25	0.00	-3537	3537		
A-2	Right Wall End	38.00	0.00	7855	-6933		
A-3	Right Opening 2	51.25	0.00	4971	-4049		
A-3	Left Opening 3	63.75	0.00	5496	-5495		
Line C							
	Shearline force			18922	18922		
C-1	Right Wall End	29.00	33.00	7596	-6852		
C-2	Right Opening 1	35.75	33.00	6161	-5417		
C-2	Left Opening 2	48.25	33.00	5294	-4808		
C-2	Right Opening 3	56.25	33.00	3594	-3107		
C-2	Left Opening 4	71.75	33.00	2243	-2038		
C-2	Right Opening 4	74.50	33.00	1658	-1453		
C-2	Left Opening 5	79.25	33.00	1224	-1102		
C-2	Right Opening 5	82.00	33.00	640	-517		
Level 2							
Line-Wall	Position on Wall or Opening	X	Y	--->	<---	--->	<---
Line 1							
	Shearline force			7543	7543		
1-1	Left Opening 1	0.00	3.00	682	-847		
1-1	Right Opening 1	0.00	12.75	-1546	1382		
1-1	Left Opening 2	0.00	20.00	1157	-1359		
1-1	Right Opening 2	0.00	29.75	-1072	869		
Line 2							
2-1	Right Wall End	38.25	19.00	8337	8337		
				3537	-3537		
Line 3							
	Shearline force			7249	7249		
3-1	Right Opening 1	47.00	5.00	-1098	1098		
3-1	Right Wall End	47.00	19.00	3075	-3075		
Line 6							
	Shearline force			6472	6472		
6-1	Left Opening 1	89.00	7.75	607	-607		
6-1	Right Opening 1	89.00	10.25	-140	140		
6-1	Left Opening 2	89.00	14.75	321	-321		
6-1	Right Opening 2	89.00	17.00	-377	377		
6-1	Left Opening 3	89.00	22.75	140	-140		
6-1	Right Opening 3	89.00	25.25	-607	607		
Line A							
	Shearline force			14896	14896		
A-2	Left Wall End	11.50	0.00	-1925	1925		
A-2	Left Opening 1	18.50	0.00	1219	-1325		
A-2	Right Opening 1	23.25	0.00	-1094	1025		
A-2	Left Opening 2	31.50	0.00	2611	-2806		
A-2	Right Opening 2	34.00	0.00	2192	-2387		
A-2	Left Opening 3	41.25	0.00	3876	-4143		
A-2	Right Opening 3	44.25	0.00	3374	-3641		
A-2	Left Opening 4	48.25	0.00	4303	-4609		
A-2	Right Opening 5	55.75	0.00	3048	-3354		
A-2	Right Wall End	58.50	0.00	3686	-4020		
A-3	Left Wall End	72.50	0.00	1343	-1676		
A-3	Left Opening 1	77.00	0.00	1476	-1606		

WoodWorks® Shearwalls

COLLECTOR FORCES (flexible seismic design, continued)

A-3	Right Opening 1	79.75	0.00	1016	-1146	
A-3	Left Opening 2	82.75	0.00	787	-855	
A-3	Right Opening 2	85.50	0.00	327	-395	
Line C						
	Shearline force			14705	14705	
C-1	Right Opening 1	4.50	33.00	-744	744	
C-1	Left Opening 2	12.50	33.00	-306	306	
C-1	Right Opening 2	14.75	33.00	-678	678	
C-1	Left Opening 3	18.75	33.00	-459	459	
C-1	Right Opening 3	21.00	33.00	-831	831	
C-1	Left Opening 4	31.25	33.00	-271	271	
C-1	Right Opening 4	33.75	33.00	-684	684	
C-1	Left Opening 5	57.50	33.00	1302	-1302	
C-1	Right Opening 5	63.25	33.00	352	-352	
C-1	Left Opening 6	70.00	33.00	721	-721	
C-1	Right Opening 6	72.25	33.00	349	-349	
C-1	Left Opening 7	77.50	33.00	636	-636	
C-1	Right Opening 7	83.25	33.00	-481	481	
Level 3						
Line-Wall	Position on Wall or Opening	Location [ft]		Drag Strut Force [lbs]		Strap/Blocking Force [lbs]
		X	Y	--->	<---	---> <---
Line 1						
	Shearline force			5196	5196	
1-1	Left Opening 1	0.00	3.00	-360	271	
1-1	Right Opening 1	0.00	12.75	-1895	1806	
1-1	Left Opening 2	0.00	20.00	1585	-1671	
1-1	Right Opening 2	0.00	29.75	50	-136	
Line 2						
	Shearline force			5849	5849	
2-1	Right Wall End	38.25	19.00	2481	-2481	
Line 3						
	Shearline force			4663	4663	
3-1	Right Opening 1	47.00	5.00	-707	707	
3-1	Right Wall End	47.00	19.00	1978	-1978	
Line 6						
	Shearline force			4028	4028	
6-1	Left Opening 1	89.00	7.75	378	-378	
6-1	Right Opening 1	89.00	10.25	-87	87	
6-1	Left Opening 2	89.00	14.75	200	-200	
6-1	Right Opening 2	89.00	17.00	-235	235	
6-1	Left Opening 3	89.00	22.75	87	-87	
6-1	Right Opening 3	89.00	25.25	-378	378	
Line A						
	Shearline force			9885	9885	
A-2	Left Wall End	11.50	0.00	-1277	1277	
A-2	Left Opening 1	18.50	0.00	975	-976	
A-2	Right Opening 1	23.25	0.00	-666	666	
A-2	Left Opening 2	31.50	0.00	1989	-1990	
A-2	Right Opening 2	34.00	0.00	1711	-1712	
A-2	Left Opening 3	41.25	0.00	2891	-2892	
A-2	Right Opening 3	44.25	0.00	2558	-2559	
A-2	Left Opening 4	48.25	0.00	3208	-3210	
A-2	Right Opening 5	55.75	0.00	2376	-2377	
A-2	Right Wall End	58.50	0.00	2823	-2824	
A-3	Left Wall End	72.50	0.00	1268	-1269	
A-3	Left Opening 1	77.00	0.00	1130	-1131	
A-3	Right Opening 1	79.75	0.00	825	-825	
A-3	Left Opening 2	82.75	0.00	603	-604	
A-3	Right Opening 2	85.50	0.00	298	-298	
Line C						
	Shearline force			9851	9851	
C-1	Right Opening 1	4.50	33.00	-498	498	
C-1	Left Opening 2	11.25	33.00	-359	359	
C-1	Right Opening 2	13.75	33.00	-636	636	
C-1	Left Opening 3	23.25	33.00	-440	440	
C-1	Right Opening 3	25.75	33.00	-717	717	
C-1	Left Opening 4	57.50	33.00	1156	-1156	
C-1	Right Opening 4	63.25	33.00	520	-520	
C-1	Left Opening 5	70.00	33.00	659	-659	
C-1	Right Opening 5	72.25	33.00	410	-410	
C-1	Left Opening 6	77.50	33.00	518	-518	
C-1	Right Opening 6	83.25	33.00	-339	339	
Level 4						
				Drag Strut		Strap/Blocking

WoodWorks® Shearwalls

COLLECTOR FORCES (flexible seismic design, continued)

Line-Wall	Position on Wall or Opening	Location [ft]		Force [lbs]		Force [lbs]	
		X	Y	--->	<---	--->	<---
Line 1							
	Shearline force			2681	2681		
1-1	Left Opening 1	0.00	3.00	-82	20		
1-1	Right Opening 1	0.00	12.75	-874	813		
1-1	Left Opening 2	0.00	20.00	872	-937		
1-1	Right Opening 2	0.00	29.75	80	-145		
Line 2							
	Shearline force			2681	2681		
2-1	Left Opening 1	38.25	11.75	955	-955		
2-1	Right Opening 1	38.25	14.00	772	-772		
2-1	Right Wall End	38.25	18.75	1158	-1158		
Line A							
	Shearline force			2685	2685		
A-2	Left Wall End	12.50	0.00	-877	877		
A-2	Left Opening 1	18.50	0.00	200	-200		
A-2	Right Opening 1	23.25	0.00	-508	508		
A-2	Left Opening 2	29.50	0.00	614	-614		
Line C							
	Shearline force			2677	2677		
C-1	Right Opening 1	4.50	33.00	-315	315		
C-1	Left Opening 2	11.25	33.00	381	-381		
C-1	Right Opening 3	18.75	33.00	-747	747		
C-1	Left Opening 4	29.50	33.00	361	-361		
C-1	Right Opening 4	35.25	33.00	-309	309		

Legend:

Line-Wall - Shearline and wall number

Position ... - Side of opening or wall end that drag strut is attached to

Location - Co-ordinates in Plan View

Drag strut Force - Axial force in transfer element at openings, gaps, or changes in design shear along shearline. + : tension; - : compression.

Based on ASD-factored shearline force shown. For SDC C-F, it is the greater of the design shearline force and the diaphragm force F_{px} , added to shearline force from story above and to forces transferred from discontinuous shearlines factored by overstrength (ω) as per 12.10.1.1.

Refer to Seismic Information table for diaphragm forces and ω factor.

For SDC D-F, if horizontal torsional irregularities 2, 3, or 4 are input, or vertical irregularity 4 detected or input, 25% increase from 12.3.3.4 applied.

For perforated walls, this force is converted to v_{max} using 4.3.6.4.1.1.

Strap/Blocking Force – For FTAO walls, force transferred from above and below opening to shearwall pier.

-> Due to shearline force in the west-to-east or south-to-north direction

<- Due to shearline force in the east-to-west or north-to-south direction

WoodWorks® Shearwalls

DEFLECTION (flexible seismic design)

Wall, segment	W Gp	Dir	Srf	v plf	b ft	h ft	Bending A sq.in	Defl in	Ga kips/in	Nail slip Vn lbs	en in	Shear Defl in	Hold Defl in	Total Defl in
Level 1														
Line 1														
1-1	1	S->N	Comb	867.7	7.50	14.75	16.5	.129	132.1	126	.003	.097	1.34	1.57
		N->S	Comb	676.7	7.50	14.75	16.5	.100	132.1	126	.003	.076	1.37	1.55
1-3	1	S->N	Comb	631.3	7.50	14.75	16.5	.094	132.1	126	.003	.070	1.40	1.57
		N->S	Comb	822.2	7.50	14.75	16.5	.122	132.1	126	.003	.092	1.33	1.55
Line 2														
2-1	8	S->N	1S	651.1	19.00	14.75	16.5	.038	38.6	149	.017	.249	0.41	0.70
		N->S	1S	651.1	19.00	14.75	16.5	.038	38.6	149	.017	.249	0.60	0.88
Line 3														
3-1,2	8	S->N	1S	776.3	14.00	14.75	16.5	.062	38.6	149	.017	.297	1.23	1.59
		N->S	1S	776.3	14.00	14.75	16.5	.062	38.6	149	.017	.297	1.30	1.66
Line 6														
6-1	1	S->N	Comb	800.4	7.50	14.75	16.5	.119	132.1	126	.003	.089	1.10	1.30
		N->S	Comb	500.8	7.50	14.75	16.5	.074	132.1	126	.003	.056	1.17	1.30
6-3	1	S->N	Comb	500.8	7.50	14.75	16.5	.074	132.1	126	.003	.056	1.17	1.30
		N->S	Comb	800.4	7.50	14.75	16.5	.119	132.1	126	.003	.089	1.10	1.30
Line A														
A-2	1	W->E	Comb	853.8	21.75	14.75	16.5	.044	132.1	126	.003	.095	0.38	0.52
		E->W	Comb	805.0	21.75	14.75	16.5	.041	132.1	126	.003	.090	0.33	0.46
A-3	2	W->E	ExtS	298.9	12.50	14.75	16.5	.027	13.4	183	.031	.329	0.00	0.36
		E->W	ExtS	383.9	12.50	14.75	16.5	.034	13.4	183	.031	.423	0.00	0.46
Line C														
C-1	1	W->E	Comb	550.0	29.00	14.75	16.5	.021	132.1	126	.003	.061	0.18	0.26
		E->W	Comb	520.3	29.00	14.75	16.5	.020	132.1	126	.003	.058	0.20	0.28
C-2	2	W->E	ExtS	166.1	37.70	14.75	16.5	.005	13.4	183	.031	.183	0.07	0.26
		E->W	ExtS	190.0	37.70	14.75	16.5	.006	13.4	183	.031	.209	0.07	0.28
Wall, segment	W Gp	Dir	Srf	v plf	b ft	h ft	Bending A sq.in	Defl in	Ga kips/in	Nail slip Vn lbs	en in	Shear Defl in	Hold Defl in	Total Defl in
Level 2														
Line 1														
1-1,1	5	S->N	Comb	579.5	3.00	9.00	16.5	.049	111.9	165	.008	.047	1.50	1.59
		N->S	Comb	649.1	3.00	9.00	16.5	.055	111.9	165	.008	.052	1.50	1.60
1-1,2		S->N	Comb	764.3	7.25	9.00	16.5	.027	111.9	165	.008	.061	1.50	1.59
		N->S	Comb	770.9	7.25	9.00	16.5	.027	111.9	165	.008	.062	1.51	1.60
1-1,3		S->N	Comb	709.4	3.25	9.00	16.5	.055	111.9	165	.008	.057	1.48	1.59
		N->S	Comb	630.4	3.25	9.00	16.5	.049	111.9	165	.008	.051	1.50	1.60
Line 2														
2-1	7	S->N	1S	559.5	19.00	9.00	16.5	.007	25.3	171	.025	.199	0.23	0.44
		N->S	1S	559.5	19.00	9.00	16.5	.007	25.3	171	.025	.199	0.07	0.27
Line 3														
3-1,2	7	S->N	1S	641.7	14.00	9.00	16.5	.012	25.3	171	.025	.228	0.46	0.70
		N->S	1S	641.7	14.00	9.00	16.5	.012	25.3	171	.025	.228	0.35	0.59
Line 6														
6-1	9	Both	ExtS	337.7	25.75	9.00	16.5	.003	19.4	178	.028	.157	0.14	0.30
Line A														
A-2	3	W->E	ExtS	773.0	27.74	9.00	16.5	.010	38.6	149	.017	.180	0.27	0.46
		E->W	ExtS	792.1	27.74	9.00	16.5	.010	38.6	149	.017	.185	0.23	0.42
A-3	4	W->E	ExtS	279.3	9.22	9.00	16.5	.008	25.3	171	.025	.099	0.35	0.46
		E->W	ExtS	215.3	9.22	9.00	16.5	.006	25.3	171	.025	.077	0.33	0.42
Line C														
C-1	2	Both	ExtS	312.8	63.31	9.00	16.5	.001	13.4	183	.031	.210	0.04	0.25
Wall, segment	W Gp	Dir	Srf	v plf	b ft	h ft	Bending A sq.in	Defl in	Ga kips/in	Nail slip Vn lbs	en in	Shear Defl in	Hold Defl in	Total Defl in
Level 3														
Line 1														
1-1,1	6	S->N	ExtS	51.6	3.00	9.00	16.5	.004	56.0	165	.008	.008	1.01	1.02
		N->S	ExtS	92.8	3.00	9.00	16.5	.008	56.0	165	.008	.015	1.00	1.02
1-1,2		S->N	ExtS	881.5	7.25	9.00	16.5	.031	56.0	165	.008	.142	0.84	1.02
		N->S	ExtS	880.8	7.25	9.00	16.5	.031	56.0	165	.008	.142	0.84	1.02
1-1,3		S->N	ExtS	196.3	3.25	9.00	16.5	.015	56.0	165	.008	.032	0.97	1.02
		N->S	ExtS	159.9	3.25	9.00	16.5	.012	56.0	165	.008	.026	0.98	1.02
Line 2														
2-1	7	S->N	1S	423.9	19.00	9.00	16.5	.006	25.3	171	.025	.151	0.18	0.34
		N->S	1S	423.9	19.00	9.00	16.5	.006	25.3	171	.025	.151	0.01	0.17
Line 3														
3-1,2	7	S->N	1S	444.2	14.00	9.00	16.5	.008	25.3	171	.025	.158	0.28	0.45

WoodWorks® Shearwalls

DEFLECTION (flexible seismic design, continued)

Wall, segment	W Gp	Dir	Srf	v plf	b ft	h ft	Bending A sq.in	Defl in	Ga kips/in	Nail slip Vn lbs	en in	Shear Defl in	Hold Defl in	Total Defl in
Line 6		N->S	IS	444.2	14.00	9.00	16.5	.008	25.3	171	.025	.158	0.24	0.41
6-1	2	Both	ExtS	227.8	25.75	9.00	16.5	.002	13.4	183	.031	.153	0.11	0.26
Line A														
A-2	4	W->E	ExtS	588.4	27.74	9.00	16.5	.005	25.3	171	.025	.209	0.13	0.34
		E->W	ExtS	588.5	27.74	9.00	16.5	.005	25.3	171	.025	.210	0.13	0.34
A-3	4	W->E	ExtS	123.7	9.22	9.00	16.5	.003	25.3	171	.025	.044	0.30	0.34
		E->W	ExtS	123.4	9.22	9.00	16.5	.003	25.3	171	.025	.044	0.30	0.34
Line C														
C-1	2	Both	ExtS	230.6	65.75	9.00	16.5	.001	13.4	183	.031	.155	0.04	0.19
Level 4														
Line 1														
1-1,1	7	S->N	ExtS	77.1	3.00	9.00	16.5	.006	25.3	171	.025	.027	0.97	1.00
		N->S	ExtS	106.4	3.00	9.00	16.5	.009	25.3	171	.025	.038	0.96	1.01
1-1,2		S->N	ExtS	460.1	7.25	9.00	16.5	.016	25.3	171	.025	.164	0.48	0.66
		N->S	ExtS	460.8	7.25	9.00	16.5	.016	25.3	171	.025	.164	0.48	0.66
1-1,3		S->N	ExtS	81.0	3.25	9.00	16.5	.006	25.3	171	.025	.029	0.86	0.89
		N->S	ExtS	52.3	3.25	9.00	16.5	.004	25.3	171	.025	.019	0.87	0.89
Line 2														
2-1	2	Both	ExtS	232.1	16.50	9.00	16.5	.004	13.4	183	.031	.156	0.18	0.34
Line A														
A-2	4	Both	ExtS	356.9	12.25	9.00	16.5	.007	25.3	171	.025	.127	0.25	0.39
Line C														
C-1	2	W->E	ExtS	247.4	19.50	9.00	16.5	.003	13.4	183	.031	.166	0.15	0.31
		E->W	ExtS	247.4	19.50	9.00	16.5	.003	13.4	183	.031	.166	0.15	0.32

Legend:

Wall, segment – Wall and segment between openings, e.g. B-3,2 = second segment on Wall 3 on Shearline B.

W Gp – Wall design group, refer to Sheathing and Framing Materials tables.

Dir – Force direction.

Srf – Wall surface = Int(erior) or Ext(erior) for perimeter walls, 1 or 2 for interior partitions; Comb = Combined v and Ga for identical materials on each side; S = Ga from side with stronger shear resistance; W = 2 x Ga of weaker side.

v – Unfactored (strength-level) shear force per unit distance on wall segment = ASD force / 0.70, as per ASCE 7 12.8.6.

Unblocked walls = v / Cub as per SDPWS 4.3.4.3, Cub = Unblocked factor from 4.3.5.3, shown in the Shear Results table.

Perforated walls = v_{max} from Eqn. 4.3-9, as per 4.3.4.2.

FTAO walls = Unit shear force in pier beside opening(s).

b – Wall or segment length.

Segmented wall or FTAO wall segments = Width of wall segment between openings.

Perforated wall = Sum of FHS segments, modified as in 4.3.3.4 per 4.3.4.2.

FTAO wall = Length of wall including openings.

h – Wall height.

FTAO piers = Distance from bottom of opening to top of wall; for end segments, results using that distance and the wall height are averaged.

Defl – Horizontal shear wall deflection due to given term:

Bending = $8vh^3 / EAb$; A = Effective cross sectional area of segment end stud(s), E = stud mod. of elasticity in Framing Materials table

For i studs at one end and j at the other, $A = 2ij / (i + j)$ x area of one stud, based on Ex. C4.3.4-3

Shear = $vh / 1000 Ga$; $Ga = 1.4 vs / (1.4 vs / Gvtv + 0.75 en)$ from SDPWS Eqn. C4.2.3-3.

vs = ASD sheathing capacity.

Gvtv = Shear stiffness from C4.3.4, shown in Sheathing Materials table.

en = Nail slip from Table C4.2.3D, of form aVn^b for WSP, varies linearly to value at capacity for other materials.

Vn = Strength-level shear force per nail along panel edge at ASD capacity = 1.4 vs.

Hold – Anchorage system (hold-down) = $da \times h / beff$.

da = Vertical hold-down displacement; refer to Hold-down Displacement table for components.

beff = Effective wall segment length = $b - (tension\ stud\ pack\ width + hold-down\ anchor\ bolt\ offset) - (1/2\ compression\ stud\ pack\ width)$

beff is given in the Shear Wall Dimensions table.

For FTAO walls, hold-down device at end of wall is applied to all segments, as per APA T555.

Total Defl – Deflection from bending + shear + hold-down, as per Eqn. 4.3-2.

For FTAO walls, the average of the values for the segments, as per APA T555.

WARNING - On shearline(s) A, 1 the program was unable to equalize deflections on the shearwall segments. Change design setting to capacity-based rigidity, or turn off the distribution to segments based on rigidity.

WoodWorks® Shearwalls

HOLD-DOWN DISPLACEMENT (flexible seismic design)

Wall, segment	Dir	Hold-down	Tens. force lbs	Vert. Displacement			Slippage		Shrink +Extra in	Comp. force lbs	Crush da in	Total da in	Horz Defl in
				Manuf in	Add in	da in	Vf lbs	da in					
Level 1													
Line 1													
1-1	S->N	HDU5-SDS	13626	.381	.016	0.397	-	-	.156	14302	0.11	0.66	1.34
	N->S	HDU5-SDS	6923	.194	.008	0.202	-	-	.156	20533	0.32	0.67	1.37
1-3	S->N	HDU5-SDS	6437	.180	.007	0.188	-	-	.156	21158	0.35	0.69	1.40
	N->S	HDU5-SDS	13986	.391	.016	0.408	-	-	.156	13608	0.09	0.66	1.33
Line 2													
2-1	S->N	HDU5-SDS	12719	.356	.015	0.371	-	-	.156	0	0.00	0.53	0.41
	N->S	HDU5-SDS	0	.000	.000	0.000	-	-	.000	27478	0.76	0.76	0.60
Line 3													
3-1,2	S->N	HDU5-SDS	13846	.388	.016	0.404	-	-	.156	25277	0.59	1.15	1.23
	N->S	HDU5-SDS	14072	.394	.016	0.410	-	-	.156	26063	0.65	1.21	1.30
Line 6													
6-1	S->N	HDU5-SDS	10230	.286	.012	0.298	-	-	.156	13257	0.08	0.54	1.10
	N->S	HDU5-SDS	5056	.142	.006	0.147	-	-	.156	19585	0.27	0.58	1.17
6-3	S->N	HDU5-SDS	5056	.142	.006	0.147	-	-	.156	19585	0.27	0.58	1.17
	N->S	HDU5-SDS	10230	.286	.012	0.298	-	-	.156	13257	0.08	0.54	1.10
Line A													
A-2	W->E	HDU5-SDS	10411	.291	.012	0.304	-	-	.156	13775	0.10	0.55	0.38
	E->W	HDU5-SDS	8955	.251	.010	0.261	-	-	.156	11695	0.06	0.48	0.33
A-3	W->E	HDU5-SDS	0	.000	.000	0.000	-	-	.000	402	0.00	0.00	0.00
	E->W	HDU5-SDS	0	.000	.000	0.000	-	-	.000	246	0.00	0.00	0.00
Line C													
C-1	W->E	HDU5-SDS	4260	.119	.005	0.124	-	-	.156	11944	0.06	0.34	0.18
	E->W	HDU5-SDS	4234	.119	.005	0.123	-	-	.156	14332	0.11	0.39	0.20
C-2	W->E	HDU5-SDS	499	.014	.001	0.015	-	-	.156	-509	0.00	0.17	0.07
	E->W	HDU5-SDS	357	.010	.000	0.010	-	-	.156	-713	0.00	0.17	0.07
Wall, segment	Dir	Hold-down	Tens. force lbs	Vert. Displacement			Slippage		Shrink +Extra in	Comp. force lbs	Crush da in	Total da in	Horz Defl in
Level 2													
Line 1													
1-1,1	S->N	HDU5-SDS	4663	.131	.012	0.142	-	-	.276	10286	0.04	0.46	1.50
	N->S	HDU5-SDS	4907	.137	.012	0.150	-	-	.276	9144	0.03	0.46	1.50
1-1,2	S->N	HDU5-SDS	12532	.351	.031	0.382	-	-	.276	24119	0.51	1.17	1.50
	N->S	HDU5-SDS	12575	.352	.032	0.384	-	-	.276	24181	0.52	1.18	1.51
1-1,3	S->N	HDU5-SDS	5767	.161	.014	0.176	-	-	.276	10464	0.04	0.49	1.48
	N->S	HDU5-SDS	5509	.154	.014	0.168	-	-	.276	11586	0.06	0.50	1.50
Line 2													
2-1	S->N	HDU5-SDS	6552	.183	.016	0.200	-	-	.276	0	0.00	0.48	0.23
	N->S	HDU5-SDS	0	.000	.000	0.000	-	-	.000	15505	0.14	0.14	0.07
Line 3													
3-1,2	S->N	HDU5-SDS	6262	.351	.012	0.362	-	-	.276	11967	0.06	0.70	0.46
	N->S	HDU5-SDS	6386	.179	.016	0.195	-	-	.276	12399	0.07	0.54	0.35
Line 6													
6-1	Both	HDU5-SDS	1986	.056	.005	0.061	-	-	.276	10881	0.05	0.38	0.14
Line A													
A-2	W->E	HDU5-SDS	3744	.210	.007	0.216	-	-	.276	20714	0.32	0.82	0.27
	E->W	HDU5-SDS	6370	.357	.012	0.368	-	-	.276	11251	0.05	0.70	0.23
A-3	W->E	HDU5-SDS	1778	.050	.004	0.054	-	-	.276	6563	0.02	0.35	0.35
	E->W	HDU5-SDS	1364	.038	.003	0.042	-	-	.276	5970	0.02	0.33	0.33
Line C													
C-1	Both	HDU5-SDS	202	.006	.001	0.006	-	-	.276	-288	0.00	0.28	0.04
Wall, segment	Dir	Hold-down	Tens. force lbs	Vert. Displacement			Slippage		Shrink +Extra in	Comp. force lbs	Crush da in	Total da in	Horz Defl in
Level 3													
Line 1													
1-1,1	S->N	HDU5-SDS	755	.021	.002	0.023	-	-	.276	3495	0.01	0.31	1.01
	N->S	HDU5-SDS	762	.021	.002	0.023	-	-	.276	2512	0.01	0.31	1.00
1-1,2	S->N	HDU5-SDS	7967	.223	.020	0.243	-	-	.276	15526	0.14	0.66	0.84
	N->S	HDU5-SDS	7968	.223	.020	0.243	-	-	.276	15526	0.14	0.66	0.84
1-1,3	S->N	HDU5-SDS	1248	.035	.003	0.038	-	-	.276	3267	0.01	0.32	0.97
	N->S	HDU5-SDS	1288	.036	.003	0.039	-	-	.276	4317	0.01	0.33	0.98
Line 2													
2-1	S->N	HDU5-SDS	3373	.094	.008	0.103	-	-	.276	0	0.00	0.38	0.18
	N->S	HDU5-SDS	0	.000	.000	0.000	-	-	.000	9034	0.03	0.03	0.01
Line 3													
3-1,2	S->N	HDU5-SDS	2497	.140	.005	0.144	-	-	.276	5078	0.01	0.43	0.28

WoodWorks® Shearwalls

HOLD-DOWN DISPLACEMENT (flexible seismic design, continued)

Line	Dir	Hold-down	Tens. force lbs	Vert. Displacement			Slippage		Shrink + Extra	Comp. force lbs	Crush	Total	Horz Defl
segment	Dir	Hold-down	force lbs	Manuf in	Add in	da in	Vf lbs	da in	+Extra in	force lbs	da in	da in	in
Line 6	N->S	HDU5-SDS	2559	.072	.006	0.078	-	-	.276	5294	0.01	0.37	0.24
6-1	Both	HDU5-SDS	657	.018	.002	0.020	-	-	.276	4961	0.01	0.31	0.11
Line A													
A-2	W->E	HDU5-SDS	2514	.070	.006	0.077	-	-	.276	9636	0.04	0.39	0.13
	E->W	HDU5-SDS	2504	.070	.006	0.076	-	-	.276	9600	0.03	0.39	0.13
A-3	W->E	HDU5-SDS	387	.013	.001	0.014	-	-	.276	2565	0.01	0.30	0.30
	E->W	HDU5-SDS	386	.013	.001	0.014	-	-	.276	2562	0.01	0.30	0.30
Line C													
C-1	Both	HDU5-SDS	216	.006	.001	0.007	-	-	.276	-309	0.00	0.28	0.04

Legend:

Wall, segment – Wall and segment between openings, e.g. B-3,2 = second segment on Wall 3 on Shearline B

Dir – Force direction

Tens., Comp. – Accumulated ASD hold-down tension force T and strength-level end compression force C from overturning, dead and vertical earthquake loads.

Tens. – ASD-factored force, used for proportion of manufacturer's maximum elongation

Comp. – Strength level force as per ASCE 12.8.6

da – Vertical displacements due to the following components:

Vert. Displacement – Elongation when slippage calculated separately; displacement when combined elongation/slippage used

Manuf – Using manufacturer's value for anchor bolt length, or no bolt contribution for connector-only elongation

Unless marked with * = (ASD tension force / ASD hold-down capacity) x max strength-level elongation or displacement

* - Maximum strength-level elongation or displacement is used. May result in higher than actual displacements for lightly loaded hold-downs, causing the segment to draw less force due to lower than actual stiffness.

Ad – Due to longer anchor bolt length than manufacturer's value, or entire bolt length for connector-only elongation = $TL / (Ab \times Es)$

T = Strength level tension force (not shown)

Ab = bolt cross-sectional area

Es = steel modulus = 29000000 psi

L = Lb – Lh

Lb = Total bolt length shown in Storey Information table

Lh = Manufacturer's anchor bolt length for given displacement/elongation from hold-down database

Slippage – Due to vertical slippage of hold-down fasteners attached to stud(s) when not combined with elongation

Nails = en from SDPWS Table C4.2.3D using values for wood structural panels

Bolts = $Vf / (270,000 D^{1.5})$ (NDS 11.3.6); D = bolt diameter, Vf = Tension force T / number of fasteners

Shrink + Extra – Wood shrinkage plus extra displacement due to mis-cuts, gaps, etc.

Shrinkage = $0.002 \times (15\% \text{ fabrication} - 10\% \text{ in-service moisture contents}) \times Ls$

Ls = Length between anchor bolt fasteners subject to perp-to-grain shrinkage; see Story Information table

Crush – Deformation of bottom plate at compression end of wall segment

= $0.02'' \times [r / 0.73, r < 0.73; (1 + (r - 0.73) / 0.27), 0.73 < r < 1; 2r^3, r > 1]$

r = fcp / Fcp' ; $Fcp' = Ct CM Fcp$; $fcp = C / A$, A = cross sectional area of end studs

Total da – Vert. Displacement + Slippage + Shrink + Crush + Extra

Horz Defl – Anchorage deflection term in SDPWS Eqn. C.4.3.4-1 = $h / beff \times da$

h = Wall height. For end segments in FTAO walls, h is the average of the wall height and the distance from the bottom of opening to top of wall

beff = Effective wall segment length = b - (tension stud pack width + hold-down anchor bolt offset) - (1/2 compression stud pack width)

h and b are shown in Deflection table, beff in the Shear Wall Dimensions table

WoodWorks® Shearwalls

STORY DRIFT (flexible seismic design)

Level	Dir	Actual Story Drift (in)							Allowable Story Drift			
		Const defl	Max dxe	Line	Max dx	Center of Mass	C of M dxe	C of M dx	hsx ft	Delta a in	Ratio Max	Ratio C of M
1	N<->S	0.16	1.66	3	6.14	44.51	1.44	5.40	16.75	5.03	1.22*	1.07
	E<->W	0.00	0.46	A	1.83	16.08	0.37	1.40				
2	N<->S	0.34	1.60	1	5.37	44.42	0.50	1.62	11.00	3.30	1.63*	0.49
	E<->W	0.09	0.42	A	1.42	16.26	0.34	1.16				
3	N<->S	0.34	1.02	1	3.03	48.62	0.40	1.08	11.00	3.30	0.92	0.33
	E<->W	0.09	0.34	A	1.10	16.47	0.27	0.88				
4	N<->S	0.34	0.66	1	1.61	19.12	0.50	1.25	9.00	2.70	0.60	0.46
	E<->W	0.20	0.39	A	0.96	16.48	0.35	0.92				

ASCE 7 Eqn. 12.8-15: $dx = dxc + (dxe - dxc) Cd / I_e$

Deflection amplification factor Cd from Table 12.2-1 = 4.0 (E-W), 4.0 (N-S)

Importance factor $I_e = 1.00$

Legend:

Const defl (dxc) – Deflection due to shrinkage, gaps, bolt hole, etc. (constant with respect to force)

Max dxe – Largest deflection for any shearline on level in this direction; refer to Deflections table

Line – Shearline with largest deflection on level in this direction

hsx – Story height in ASCE Table 12.12-1 = Height of walls plus joist depth between this level and the one above.

Max dx – Largest amplified deflection on level in this direction using ASCE 7 Eq'n 12.8-15

C of M dxe - Deflection at the center of mass of this level; from interpolating deflections at adjacent shearlines.

C of M dx - Amplified deflection at center of mass using Eq'n 12.8-15. Does not include differences between top and bottom diaphragm deflection.

Delta a = Allowable story drift on this level from ASCE 7 Table 12.12-1

Ratio - Proportion of allowable story drift experienced, on this level in this direction.

Notes:

*FAILURE – Story drift on this level is greater than maximum allowed by ASCE 7 Table 12.12-1.

Maximum of all shearlines used to satisfy flexible diaphragm assumption in 12.3.1.1.

WORK ORDER:

PROJECT:

ENGR:

DATE:

LEVEL1:

+ A-2 (9' TALL x 21'-6" WALL SECTION):

- SEISMIC: 13,000 LBF (CONTROLS) -

WIND: 8,490 LBF

$$V = 13,000/21.5' = 600 \text{ PLF} \Rightarrow \text{SW3 T/C} = \\ (13000*9')/21.5' = 5,400 \text{ LBF} \Rightarrow \text{"D" HOLD-DOWN}$$

+ A-3 (9' TALL x 12'-6" WALL SECTION):

- SEISMIC: 3,360 LBF (CONTROLS) -

WIND: 2,850 LBF

$$V = 3360/12.5' = 270 \text{ PLF} \Rightarrow \text{SW1 T/C} = (3360*9')/12.5' \\ = 2,450 \text{ LBF} \Rightarrow \text{"B" HOLD-DOWN}$$

+ C-1 (9' TALL x 27'-6" WALL SECTION):

- SEISMIC: 11,200 LBF (CONTROLS) -

WIND: 7,450 LBF

$$V = 11200/27.5' = 410 \text{ PLF} \Rightarrow \text{SW3 T/C} = \\ (11200*9')/27.5' = 3,665 \text{ LBF} \Rightarrow \text{"C" HOLD-DOWN}$$

+ 2-1 (9' TALL x 19' WALL SECTION):

- SEISMIC: 8,700 LBF - WIND:

14,000 LBF (CONTROLS)

$$V = 14000/19' = 735 \text{ PLF} \Rightarrow \text{SW4 T/C} = (14000*9')/19' \\ = 6,650 \text{ LBF} \Rightarrow \text{"E" HOLD-DOWN}$$

+ 3-1 (9' TALL x 14' WALL SECTION):

- SEISMIC: 7,600 LBF - WIND:

12,000 LBF (CONTROLS)

$$V = 12000/14' = 855 \text{ PLF} \Rightarrow \text{SW4 T/C} = (12000*9')/14' \\ = 7,725 \text{ LBF} \Rightarrow \text{"E" HOLD-DOWN}$$

Project Title:
 Engineer:
 Project ID:
 Project Descr:

2D Frame

Project File:

LIC# : KW-06019737, Build:20.25.10.02

PLIRIS

(c) ENERCALC, LLC 1982-2025

DESCRIPTION: STORE FRONT FRAME

Code References

Governing Code : IBC 2021
 Referenced Design Standard(s) : NDS 2018 , AISC 360-16
 Load Combinations Used : ASCE 7-22 / IBC 2024

Joints...

Joint Label	Joint Coordinates		X Translational Restraint	Y Translational Restraint	Z Rotational Restraint	Joint Temp deg F
	X ft	Y ft				
1	0.0	0.0	Restrained	Restrained	Restrained	0
2	0.0	14.750	Unrestrained	Unrestrained	Unrestrained	0
3	21.0	0.0	Restrained	Restrained	Restrained	0
4	21.0	14.750	Unrestrained	Unrestrained	Unrestrained	0
5	33.0	0.0	Restrained	Restrained	Restrained	0
6	33.0	14.750	Unrestrained	Unrestrained	Unrestrained	0

Members...

Member Label	Property Label	Endpoint Joints		Member Length ft	Releases Specify Connectivity of Member Ends to Joints					
		I Joint	J Joint		I End			J End		
					x	y	z (rotation)	x	y	z (rotation)
1-2	ColLine_1	1	2	14.750	Unreleased	Unreleased	Released	Unreleased	Unreleased	Unreleased
2-4	BmLvl_1	2	4	21.000	Unreleased	Unreleased	Unreleased	Unreleased	Unreleased	Unreleased
3-4	ColLine_2	3	4	14.750	Unreleased	Unreleased	Unreleased	Unreleased	Unreleased	Unreleased
4-6	BmLvl_1	4	6	12.000	Unreleased	Unreleased	Unreleased	Unreleased	Unreleased	Unreleased
5-6	ColLine_3	5	6	14.750	Unreleased	Unreleased	Unreleased	Unreleased	Unreleased	Unreleased

Member Stress Check Data...

Member Label	Unbraced Lengths				Slenderness Factors		AISC Bending & Stability Factors	
	Lu : z ft	Lu : y	Lb (ft)	Lex (ft)	K : z	K : y	Cm	Cb
1-2	14.750	14.750	14.750	30.385	1.00	1.00	Internal	Internal
2-4	21.000	21.000	21.000	43.260	1.00	1.00	Internal	Internal
3-4	14.750	14.750	14.750	30.385	1.00	1.00	Internal	Internal
4-6	12.000	12.000	11.000	22.660	1.00	1.00	Internal	Internal
5-6	14.750	14.750	14.750	30.385	1.00	1.00	Internal	Internal

Materials...

Member Label	Youngs ksi	Density kcf	Thermal in/deg	Yield ksi
Default	1.00	0.000	0.000000	1.00
Steel	29,000.00	0.490	0.000007	50.00
Wood	1,800.00	0.035	0.000000	0.00

Wood Material Data...

Wood, Not Defined, Density= 35.0pcf, FbT= 1000psi, FbC= 1000psi, Fv= 1000psi, Ft= 1000, Fc= 400psi, E Bend XX= 1800ksi, E BendMin XX= 1800ksi, E Beny YY= 1800ksi, E BendMin YY= 1800ksi, E Axial= 1800ksi, Species= , Grade= Any, Class=

Member Sections...

Prop Label	Group Tag	Material	Area	Depth	Width	Ixx	Iyy
Default	Group	Default	1.0 in^2	0.0 in	0.0 in	1.0 in^4	1.0 in^4
W21x73	ColLine_1	Steel	21.50 in^2	21.20 in	8.30 in	1,600.0 in^4	70.60 in^4
W21x73	ColLine_2	Steel	21.50 in^2	21.20 in	8.30 in	1,600.0 in^4	70.60 in^4
W21x73	ColLine_3	Steel	21.50 in^2	21.20 in	8.30 in	1,600.0 in^4	70.60 in^4
W21x73	BmLvl_1	Steel	21.50 in^2	21.20 in	8.30 in	1,600.0 in^4	70.60 in^4

Joint Loads...

Note: Loads labeled "Global Y" act downward (in "-Y" direction)

Joint Label	Load Direction	Load Magnitude						
		Dead	Roof Live	Live	Snow	Seismic	Wind	Earth
2	Global X					7.860	14.665	k

Project Title:
 Engineer:
 Project ID:
 Project Descr:

2D Frame

Project File:

LIC# : KW-06019737, Build:20.25.10.02

PLIRIS

(c) ENERCALC, LLC 1982-2025

DESCRIPTION: STORE FRONT FRAME

Member Point Loads...

Note: Loads labeled "Global Y" act downward (in "-Y" direction)

Member Label	Load Direction	Distance from "I" Joint	Load Magnitude						
			Dead	Roof Live	Live	Snow	Seismic	Wind	Earth
4-6	Global Y	11.5 ft					6.750	-6.850	k
4-6	Global Y	9.5 ft					6.750	6.850	k
4-6	Global Y	10.25 ft	6.70		13.30				k
2-4	Global Y	0.5 ft					6.750	6.850	k
2-4	Global Y	14.75 ft					-6.90	-9.0	k
2-4	Global Y	19.75 ft					6.90	-9.0	k
2-4	Global Y	2.5 ft					-6.750	-6.850	k
2-4	Global Y	18.25 ft					6.90	9.0	k
2-4	Global Y	13.25 ft					6.90	9.0	k
2-4	Global Y	14.25 ft	6.70		13.30				k
2-4	Global Y	16.5 ft	19.60		39.10				k
2-4	Global Y	1.75 ft	6.70		13.30				k
2-4	Global Y	18.75 ft	6.70		13.30				k
1-2	Global X	14.75 ft					7.90	14.650	k

Stress/Strength Load Combinations

ASCE 7-22 / IBC 2024

Load Combination Description	Cd	Load Combination Factors								
		Dead	0.2*Sds* Seismic	Roof Live	Live	Snow	Wind	Seismic	Rho	Earth
+D+H	0.9	1.0								1.0
+D+L+H	1	1.0			1.0					1.0
+D+Lr+H	1.25	1.0		1.0						1.0
+D+0.70S+H	1.15	1.0				0.70				1.0
+D+0.750Lr+0.750L+H	1.25	1.0		0.750	0.750					1.0
+D+0.750L+0.5250S+H	1.15	1.0			0.750	0.5250				1.0
+D+0.60W+H	1.6	1.0					0.60			1.0
+D+0.750Lr+0.750L+0.450W+H	1.6	1.0		0.750	0.750		0.450			1.0
+D+0.750L+0.5250S+0.450W+H	1.6	1.0			0.750	0.5250	0.450			1.0
+0.60D+0.60W+0.60H	1.6	0.60					0.60			0.60
+D+0.70E+H	0.9	1.0						0.70		1.0
+D+0.750L+0.10S+0.5250E+H	1.15	1.0			0.750	0.10		0.5250		1.0
+0.60D+0.70E+0.60H	0.9	0.60						0.70		0.60

Reaction Load Combinations

ASCE 7-22 / IBC 2024

Load Combination Description	Load Combination Factors							
	Dead	Roof Live	Live	Snow	Wind	Seismic	Rho	Earth
+D+H	1.0							1.0
+D+L+H	1.0			1.0				1.0
+D+Lr+H	1.0	1.0						1.0
+D+0.70S+H	1.0			0.70				1.0
+D+0.750Lr+0.750L+H	1.0	0.750	0.750					1.0
+D+0.750L+0.5250S+H	1.0		0.750	0.5250				1.0
+D+0.60W+H	1.0				0.60			1.0
+D+0.750Lr+0.750L+0.450W+H	1.0	0.750	0.750		0.450			1.0
+D+0.750L+0.5250S+0.450W+H	1.0		0.750	0.5250	0.450			1.0
+0.60D+0.60W+0.60H	0.60				0.60			0.60
+D+0.70E+H	1.0					0.70		1.0
+D+0.750L+0.10S+0.5250E+H	1.0		0.750	0.10		0.5250		1.0
+0.60D+0.70E+0.60H	0.60					0.70		0.60
D Only	1.0							
Lr Only		1.0						
L Only			1.0					
S Only				1.0				
W Only					1.0			
E Only						1.0		
H Only								1.0

Deflection Load Combinations

ASCE 7-22 / IBC 2024

Load Combination Description	Load Combination Factors							
	Dead	Roof Live	Live	Snow	Wind	Seismic	Rho	Earth
+D+H	1.0							1.0

Project Title:
 Engineer:
 Project ID:
 Project Descr:

2D Frame

Project File:

LIC# : KW-06019737, Build:20.25.10.02

PLIRIS

(c) ENERCALC, LLC 1982-2025

DESCRIPTION: STORE FRONT FRAME

Deflection Load Combinations

ASCE 7-22 / IBC 2024

Load Combination Description	Load Combination Factors						
	Dead	Roof Live	Live	Snow	Wind	Seismic	Earth
+D+L+H	1.0		1.0				1.0
+D+Lr+H	1.0	1.0					1.0
+D+0.70S+H	1.0			0.70			1.0
+D+0.750Lr+0.750L+H	1.0	0.750	0.750				1.0
+D+0.750L+0.5250S+H	1.0		0.750	0.5250			1.0
+D+0.60W+H	1.0				0.60		1.0
+D+0.750Lr+0.750L+0.450W+H	1.0	0.750	0.750		0.450		1.0
+D+0.750L+0.5250S+0.450W+H	1.0		0.750	0.5250	0.450		1.0
+0.60D+0.60W+0.60H	0.60				0.60		0.60
+D+0.70E+H	1.0					0.70	1.0
+D+0.750L+0.10S+0.5250E+H	1.0		0.750	0.10		0.5250	1.0
+0.60D+0.70E+0.60H	0.60					0.70	0.60
D Only	1.0						
Lr Only		1.0					
L Only			1.0				
S Only				1.0			
W Only					1.0		
E Only						1.0	
H Only							1.0

Extreme Joint Displacements

Only Load Combinations giving maximum values are listed

Joint Label	Joint Displacements		
	X in	Y in	Z Radians
1 Max	0.0 W Only	0.0 W Only	0.0
1 Min	0.0 +D+L	0.0 +D+L	0.0
2 Max	0.1836 W Only	0.000554 W Only	-0.000223 E Only
2 Min	-0.02937 +D+L	-0.009515 +D+L	-0.001137 +D+0.750L+0.450W
3 Max	0.0 W Only	0.0 W Only	0.0 D Only
3 Min	0.0 D Only	0.0 +D+L	0.0 W Only
4 Max	0.1728 W Only	0.002324 W Only	0.001322 +D+L
4 Min	-0.03171 +D+L	-0.02828 +D+L	-0.000338 W Only
5 Max	0.0 W Only	0.0 D Only	0.0 +D+L
5 Min	0.0 +D+L	0.0 E Only	0.0 W Only
6 Max	0.170 W Only	-0.000531 D Only	.0000380 +D+L
6 Min	-0.03107 +D+L	-0.004880 E Only	-0.000544 W Only

Extreme Joint Reactions

Only Load Combinations giving maximum values are listed

Joint Label	Joint Reactions		
	X k	Y k	Z k-ft
1 Max	5.786 +D+L	33.517 +D+L	
1 Min	-2.732 W Only	-1.952 W Only	

Project Title:
 Engineer:
 Project ID:
 Project Descr:

2D Frame

Project File:

LIC# : KW-06019737, Build:20.25.10.02

PLIRIS

(c) ENERCALC, LLC 1982-2025

DESCRIPTION: STORE FRONT FRAME

Extreme Joint Reactions

Only Load Combinations giving maximum values are listed

Joint Label	Joint Reactions		
	X k	Y k	Z k-ft
2			
Max			
Min			
3	-2.864	99.620	113.20
Max	D Only	+D+L	W Only
Min	-14.348	-8.188	11.466
	W Only	W Only	D Only
4			
Max			
Min			
5	2.782	17.191	102.12
Max	+D+L	E Only	W Only
Min	-12.235	1.871	-21.345
	W Only	D Only	+D+L
6			
Max			
Min			

Extreme Member End Forces

Only Load Combinations giving maximum values are listed

A compressive force will produce a positive Axial Member End Force value at the I end and Negative Value at the J end.

Member Label	Member " I " End Forces			Member " J " End Forces		
	Axial k	Shear k	Moment k-ft	Axial k	Shear k	Moment k-ft
1-2	33.517	0.4781	0.0	-5.560	10.186	7.053
Max	+D+L	+0.60D+0.60W	D Only	+0.60D+0.60W	+D+0.750L+0.450W	+0.60D+0.60W
1-2	5.560	-5.786	0.0	-33.517	1.935	-85.336
Min	+0.60D+0.60W	+D+L	D Only	+D+L	D Only	+D+L
2-4	17.885	33.517	85.336	-1.935	85.183	-65.831
Max	+D+0.60W	+D+L	+D+L	D Only	+D+L	+0.60D+0.70E
2-4	1.935	5.560	-7.053	-17.885	18.260	-210.63
Min	D Only	+0.60D+0.60W	+0.60D+0.60W	+D+0.60W	+0.60D+0.60W	+D+L
3-4	99.620	13.598	79.529	-15.073	-2.864	121.04
Max	+D+L	+D+0.750L+0.450W	+D+0.750L+0.450W	+0.60D+0.60W	D Only	+D+0.750L+0.450W
3-4	15.073	2.864	11.466	-99.620	-13.598	30.781
Min	+0.60D+0.60W	D Only	D Only	+D+L	+D+0.750L+0.450W	D Only
4-6	6.784	14.437	118.56	2.782	13.905	19.686
Max	+0.60D+0.60W	+D+L	+D+L	+D+L	+D+0.70E	+D+L
4-6	-2.782	-3.187	-10.429	-6.784	1.871	-43.067
Min	+D+L	+0.60D+0.60W	+0.60D+0.60W	+0.60D+0.60W	D Only	+0.60D+0.60W
5-6	13.905	6.784	56.992	-1.871	2.782	43.067
Max	+D+0.70E	+0.60D+0.60W	+0.60D+0.60W	D Only	+D+L	+0.60D+0.60W
5-6	1.871	-2.782	-21.345	-13.905	-6.784	-19.686
Min	D Only	+D+L	+D+L	+D+0.70E	+0.60D+0.60W	+D+L

Extreme Member Forces

Only Load Combinations giving maximum values are listed

Mmbr Label	Axial	Dist from "I" Joint	Moment	Dist from "I" Joint	Shear	Dist from "I" Joint
1-2	-5.560k	0.0 ft	85.336 k-ft	14.750 ft	0.4781 k	0.0 ft
Max	+0.60D+0.60W		+D+L		+0.60D+0.60W	
1-2	-33.517k	0.0 ft	-7.053 k-ft	14.750 ft	-10.186 k	14.750 ft
Min	+D+L		+0.60D+0.60W		+D+0.750L+0.450W	
2-4	-1.935k	0.0 ft	210.63 k-ft	21.0 ft	33.517 k	0.0 ft
Max	D Only		+D+L		+D+L	

Project Title:
 Engineer:
 Project ID:
 Project Descr:

2D Frame

Project File:

LIC# : KW-06019737, Build:20.25.10.02

PLIRIS

(c) ENERCALC, LLC 1982-2025

DESCRIPTION: STORE FRONT FRAME

Extreme Member Forces

Only Load Combinations giving maximum values are listed

Mmbr Label	Axial	Dist from "I" Joint	Moment	Dist from "I" Joint	Shear	Dist from "I" Joint
2-4 <i>Min</i>	-17.885k <i>+D+0.60W</i>	0.0 ft	-140.83 k-ft <i>+D+L</i>	14.143 ft	-85.183 k <i>+D+L</i>	18.857 ft
3-4 <i>Max</i>	-15.073k <i>+0.60D+0.60W</i>	0.0 ft	79.529 k-ft <i>+D+0.750L+0.450W</i>	0.0 ft	13.598 k <i>+D+0.750L+0.450W</i>	0.0 ft
3-4 <i>Min</i>	-99.620k <i>+D+L</i>	0.0 ft	-121.04 k-ft <i>+D+0.750L+0.450W</i>	14.750 ft	2.864 k <i>D Only</i>	0.0 ft
4-6 <i>Max</i>	2.782k <i>+D+L</i>	0.0 ft	118.56 k-ft <i>+D+L</i>	0.0 ft	14.437 k <i>+D+L</i>	0.0 ft
4-6 <i>Min</i>	-6.784k <i>+0.60D+0.60W</i>	0.0 ft	-29.222 k-ft <i>+D+L</i>	10.286 ft	-13.905 k <i>+D+0.70E</i>	11.510 ft
5-6 <i>Max</i>	-1.871k <i>D Only</i>	0.0 ft	56.992 k-ft <i>+0.60D+0.60W</i>	0.0 ft	6.784 k <i>+0.60D+0.60W</i>	0.0 ft
5-6 <i>Min</i>	-13.905k <i>+D+0.70E</i>	0.0 ft	-43.067 k-ft <i>+0.60D+0.60W</i>	14.750 ft	-2.782 k <i>+D+L</i>	0.0 ft

Member Stress Checks...

Stress Checks per AISC 360-16 & NDS 2018

Member Label	Section Label	Material	Max. Axial + Bending Stress Ratios				Max. Shear Stress Ratios			
			Load Combination	Ratio	Status	Dist (ft)	Load Combination	Ratio	Status	Dist (ft)
1-2	ColLine_1	Steel	+D+L	0.320	PASS	14.75	+D+0.750L+0.450W	0.053	PASS	14.75
2-4	BmLv_1	Steel	+D+L	0.931	PASS	21.00	+D+L	0.442	PASS	18.86
3-4	ColLine_2	Steel	+D+0.750L+0.450W	0.592	PASS	14.75	+D+0.750L+0.450W	0.070	PASS	0.00
4-6	BmLv_1	Steel	+D+L	0.323	PASS	0.00	+D+L	0.075	PASS	0.00
5-6	ColLine_3	Steel	+0.60D+0.60W	0.189	PASS	0.00	+0.60D+0.60W	0.035	PASS	0.00

Project Title:
Engineer:
Project ID:
Project Descr:

2D Frame

Project File:

LIC# : KW-06019737, Build:20.25.10.02

PLIRIS

(c) ENERCALC, LLC 1982-2025

DESCRIPTION: STORE FRONT FRAME

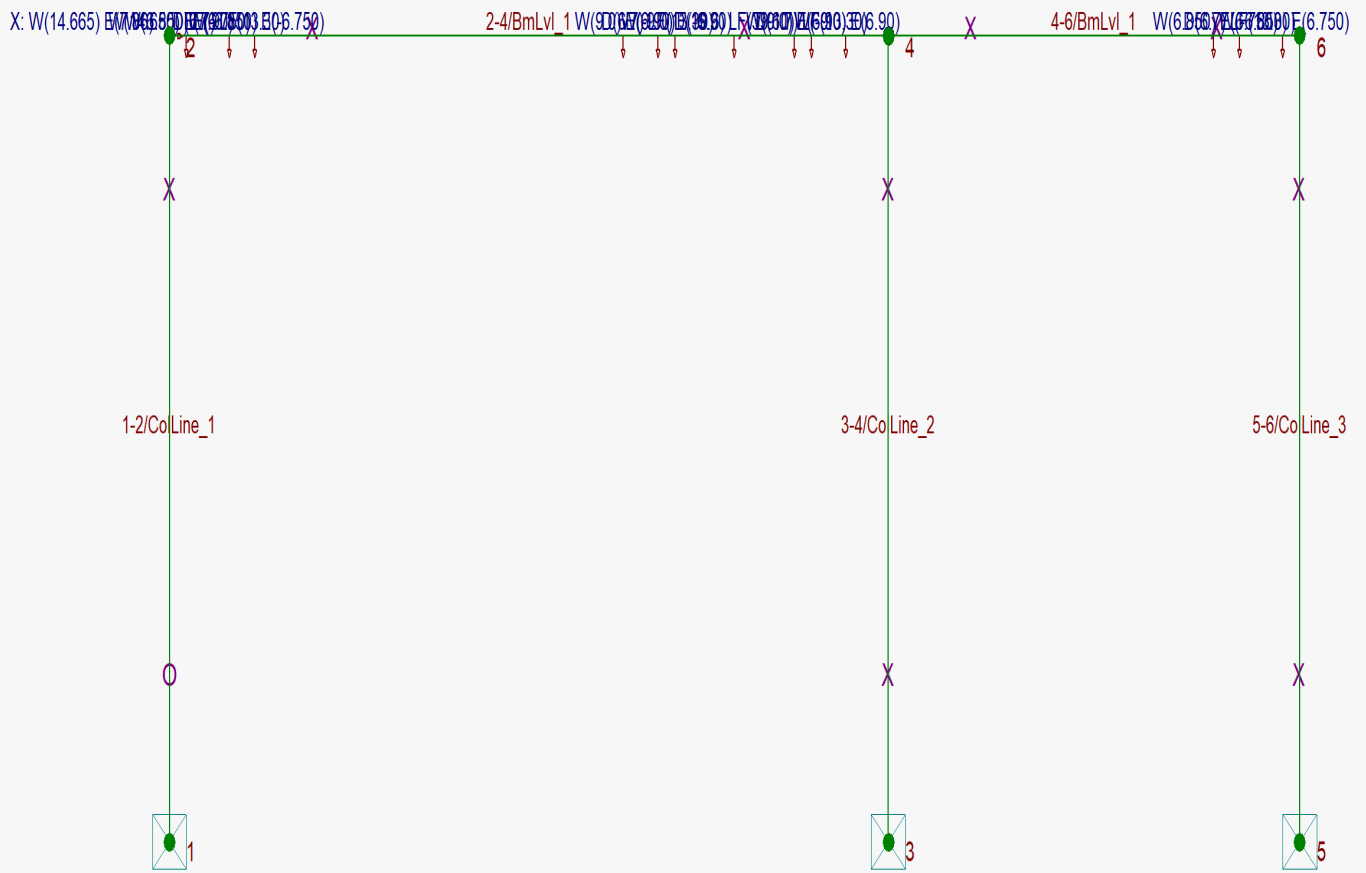

Project Title:
 Engineer:
 Project ID:
 Project Descr:

Concrete Column

Project File:

LIC# : KW-06019737, Build:20.25.10.02

PLIRIS

(c) ENERCALC, LLC 1982-2025

DESCRIPTION: GARAGE ENTRY

Code References

Governing Code : IBC 2021
 Referenced Design Standard(s) : ACI 318-19
 Load Combinations Used : ASCE 7-22 / IBC 2024

General Information

f'_c : Concrete 28 day streng = 3.0 ksi
 E = 3,122.0 ksi
 Density = 150.0 pcf
 β = 0.850
 f_y - Main Rebar = 60.0 ksi
 E - Main Rebar = 29,000.0 ksi
 Allow. Reinforcing Limits = *ASTM A615 Bars Used*
 Min. Reinf. = 1.0 %
 Max. Reinf. = 8.0 %
 Seismic Design Category = C

Overall Column Height = 10.0 ft
 End Fixity Top Pinned, Bottom Fixed
 Brace condition for deflection (buckling) along column
 X-X (width) axis :
 Fully braced against buckling ABOUT Y-Y Axis
 Y-Y (depth) axis :
 Fully braced against buckling ABOUT Y-Y Axis

Column Cross Section

Column Dimensions : 24.0in high x 14.0in Wide, Column
 Edge to Rebar Edge Cover = 2.0in

Column Reinforcing : general

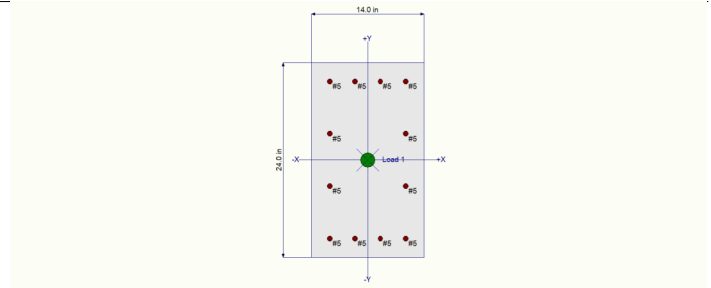

Rebar Sizes & Locations

Total bars = 12

X & Y distances measured from lower-left corner.

Bar Size #	X in	Y in	Bar Size #	X in	Y in	Bar Size #	X in	Y in	Bar Size #	X in	Y in
# 5	2.313	2.313	# 5	2.313	21.688	# 5	11.688	21.688	# 5	11.688	2.313
# 5	5.438	21.688	# 5	5.438	2.313	# 5	8.563	21.688	# 5	8.563	2.313
# 5	2.313	8.771	# 5	11.688	8.771	# 5	2.313	15.229	# 5	11.688	15.229

Applied Loads

Entered loads are factored per load combinations specified by user.

Column self weight included : 3,500.0 lbs * Dead Load Factor

AXIAL LOADS . . .

Axial Load at 10.0 ft above base, D = 13.059, LR = 0.6570, L = 10.762, S = 0.5360 k

BENDING LOADS . . .

Lat. Point Load at 10.0 ft creating M_x -x, W = 4.750, E = 3.40 k

Project Title:
 Engineer:
 Project ID:
 Project Descr:

Concrete Column

Project File:

LIC# : KW-06019737, Build:20.25.10.02

PLIRIS

(c) ENERCALC, LLC 1982-2025

DESCRIPTION: GARAGE ENTRY

DESIGN SUMMARY

Load Combination	+1.20D+0.50Lr+1.60L		Maximum SERVICE Load Reactions .			
Location of max.above base	9.933 ft		Top along Y-Y	0.0 k	Bottom along Y-Y	0.0 k
Maximum Stress Ratio	0.068 : 1		Top along X-X	4.750 k	Bottom along X-X	0.0 k
Ratio = $(Pu^2+Mu^2)^{.5} / (\Phi Pn^2+\Phi Mn^2)^{.5}$			Maximum SERVICE Load Deflections . .			
Pu = 37.419 k	$\Phi * Pn =$	556.67 k	Along Y-Y	0.0 in at	0.0 ft above base	
Mu-x = 4.116 k-ft	$\Phi * Mn-x =$	58.840 k-ft	for load combination :			
Mu-y = 0.0 k-ft	$\Phi * Mn-y =$	0.0 k-ft	Along X-X	0.0in at	0.0 ft above base	
Mu Angle = 0.0 deg	$\Phi =$	0.650	for load combination :			
Mu at Angle = 4.116 k-ft	ΦMn at Angle =	60.233 k-ft				
<i>Pn & Mn values located at Pu-Mu vector intersection with capacity curve</i>						
Column Capacities . .			General Section Information			
Pnmax : Nominal Max. Compressive Axial Capacity	1,070.51 k		β = 0.850	$\theta =$	0.80	
Pnmin : Nominal Min. Tension Axial Capacity	k		ρ : % Reinforcing	1.107 %	Rebar % Ok	
ΦPn , max : Usable Compressive Axial Capacity	556.67 k		Reinforcing Area	3.720 in ²		
ΦPn , min : Usable Tension Axial Capacity	k		Concrete Area	336.0 in ²		

Governing Load Combination Results

Governing Factored Load Combination	Moment		Dist. from base ft	Axial Load k		Bending Analysis k-ft						Utilization	
	X-X	Y-Y		Pu	$\Phi * Pn$	δx	$\delta x * Mu_x$	δy	$\delta y * Mu_y$	Alpha (deg)	δMu	ΦMn	Ratio
+1.40D	Actual	M2,min	9.93	23.18	556.67	1.000		1.000	1.97	90.000	1.97	47.43	0.042
+1.40D	M2,min	Actual	9.93	23.18	556.67	1.000	2.55	1.000		0.000	2.55	60.23	0.042
+1.20D+0.50Lr+1.60L	Actual	M2,min	9.93	37.42	556.67	1.000		1.000	3.18	90.000	3.18	47.43	0.067
+1.20D+0.50Lr+1.60L	M2,min	Actual	9.93	37.42	556.67	1.000	4.12	1.000		0.000	4.12	60.23	0.068
+1.20D+1.60L+0.30S	Actual	M2,min	9.93	37.25	556.67	1.000		1.000	3.17	90.000	3.17	47.43	0.067
+1.20D+1.60L+0.30S	M2,min	Actual	9.93	37.25	556.67	1.000	4.10	1.000		0.000	4.10	60.23	0.068
+1.20D+1.60Lr+L	Actual	M2,min	9.93	31.68	556.67	1.000		1.000	2.69	90.000	2.69	47.43	0.057
+1.20D+1.60Lr+L	M2,min	Actual	9.93	31.68	556.67	1.000	3.49	1.000		0.000	3.49	60.23	0.058
+1.20D+1.60Lr+0.50W	Actual	M2,min	9.93	20.92	556.67	1.000	-0.00	1.000	1.78	90.000	1.78	47.43	0.038
+1.20D+1.60Lr+0.50W	M2,min	Actual	9.93	20.92	556.67	1.000	2.30	1.000		0.000	2.30	60.23	0.038
+1.20D+L+S	Actual	M2,min	9.93	31.17	556.67	1.000		1.000	2.65	90.000	2.65	47.43	0.056
+1.20D+L+S	M2,min	Actual	9.93	31.17	556.67	1.000	3.43	1.000		0.000	3.43	60.23	0.057
+1.20D+S+0.50W	Actual	M2,min	9.93	20.41	556.67	1.000	-0.00	1.000	1.73	90.000	1.73	47.43	0.037
+1.20D+S+0.50W	M2,min	Actual	9.93	20.41	556.67	1.000	2.24	1.000		0.000	2.24	60.23	0.037
+1.20D+0.50Lr+L+W	Actual	M2,min	9.93	30.96	556.67	1.000	-0.00	1.000	2.63	90.000	2.63	47.43	0.056
+1.20D+0.50Lr+L+W	M2,min	Actual	9.93	30.96	556.67	1.000	3.41	1.000		0.000	3.41	60.23	0.056
+1.20D+L+0.30S+W	Actual	M2,min	9.93	30.79	556.67	1.000	-0.00	1.000	2.62	90.000	2.62	47.43	0.055
+1.20D+L+0.30S+W	M2,min	Actual	9.93	30.79	556.67	1.000	3.39	1.000		0.000	3.39	60.23	0.056
+0.90D+W	Actual	M2,min	9.93	14.90	556.67	1.000	-0.00	1.000	1.27	90.000	1.27	47.43	0.027
+0.90D+W	M2,min	Actual	9.93	14.90	556.67	1.000	1.64	1.000		0.000	1.64	60.23	0.027
+1.20D+L+0.150S+E	Actual	M2,min	9.93	30.71	556.67	1.000	-0.00	1.000	2.61	90.000	2.61	47.43	0.055
+1.20D+L+0.150S+E	M2,min	Actual	9.93	30.71	556.67	1.000	3.38	1.000		0.000	3.38	60.23	0.056
+0.90D+E	Actual	M2,min	9.93	14.90	556.67	1.000	-0.00	1.000	1.27	90.000	1.27	47.43	0.027
+0.90D+E	M2,min	Actual	9.93	14.90	556.67	1.000	1.64	1.000		0.000	1.64	60.23	0.027

Maximum Reactions

Note: Only non-zero reactions are listed.

Load Combination	X-X Axis Reaction k		Y-Y Axis Reaction k		Axial Reaction @ Base	Mx - End Moments k-ft		My - End Moments k-ft	
	@ Base	@ Top	@ Base	@ Top		@ Base	@ Top	@ Base	@ Top
D Only					16.559				
+D+L					27.321				
+D+Lr					17.216				
+D+0.70S					16.934				
+D+0.750Lr+0.750L					25.123				
+D+0.750L+0.5250S					24.912				
+D+0.60W				2.850	16.559		-0.000		

Project Title:
 Engineer:
 Project ID:
 Project Descr:

Concrete Column

Project File:

LIC# : KW-06019737, Build:20.25.10.02

PLIRIS

(c) ENERCALC, LLC 1982-2025

DESCRIPTION: GARAGE ENTRY

Maximum Reactions

Note: Only non-zero reactions are listed.

Load Combination	X-X Axis Reaction		k	Y-Y Axis Reaction		Axial Reaction	Mx - End Moments		k-ft	My - End Moments	
	@ Base	@ Top		@ Base	@ Top		@ Base	@ Base		@ Top	@ Base
+D+0.750Lr+0.750L+0.450W				2.137		25.123	-0.000				
+D+0.750L+0.5250S+0.450W				2.137		24.912	-0.000				
+0.60D+0.60W				2.850		9.935	-0.000				
+D+0.70E				2.380		16.559	-0.000				
+D+0.750L+0.10S+0.5250E				1.785		24.684	-0.000				
+0.60D+0.70E				2.380		9.935	-0.000				
Lr Only						0.657					
L Only						10.762					
S Only						0.536					
W Only				4.750			-0.000				
E Only				3.400			-0.000				

Maximum Moment Reactions

Note: Only non-zero reactions are listed.

Load Combination	Moment About X-X Axis		k-ft	Moment About Y-Y Axis		k-ft
	@ Base	@ Top		@ Base	@ Top	
D Only			k-ft			k-ft
+D+L			k-ft			k-ft
+D+Lr			k-ft			k-ft
+D+0.70S			k-ft			k-ft
+D+0.750Lr+0.750L			k-ft			k-ft
+D+0.750L+0.5250S			k-ft			k-ft
+D+0.60W	-0.000		k-ft			k-ft
+D+0.750Lr+0.750L+0.450W	-0.000		k-ft			k-ft
+D+0.750L+0.5250S+0.450W	-0.000		k-ft			k-ft
+0.60D+0.60W	-0.000		k-ft			k-ft
+D+0.70E	-0.000		k-ft			k-ft
+D+0.750L+0.10S+0.5250E	-0.000		k-ft			k-ft
+0.60D+0.70E	-0.000		k-ft			k-ft
Lr Only			k-ft			k-ft
L Only			k-ft			k-ft
S Only			k-ft			k-ft
W Only	-0.000		k-ft			k-ft
E Only	-0.000		k-ft			k-ft

Maximum Deflections for Load Combinations

Load Combination	Max. X-X Deflection		Distance	Max. Y-Y Deflection		Distance
	in	ft		in	ft	
D Only	0.0000	in	0.000	ft	0.000	in
+D+L	0.0000	in	0.000	ft	0.000	in
+D+Lr	0.0000	in	0.000	ft	0.000	in
+D+0.70S	0.0000	in	0.000	ft	0.000	in
+D+0.750Lr+0.750L	0.0000	in	0.000	ft	0.000	in
+D+0.750L+0.5250S	0.0000	in	0.000	ft	0.000	in
+D+0.60W	0.0000	in	0.000	ft	0.000	in
+D+0.750Lr+0.750L+0.450W	0.0000	in	0.000	ft	0.000	in
+D+0.750L+0.5250S+0.450W	0.0000	in	0.000	ft	0.000	in
+0.60D+0.60W	0.0000	in	0.000	ft	0.000	in
+D+0.70E	0.0000	in	0.000	ft	0.000	in
+D+0.750L+0.10S+0.5250E	0.0000	in	0.000	ft	0.000	in
+0.60D+0.70E	0.0000	in	0.000	ft	0.000	in
Lr Only	0.0000	in	0.000	ft	0.000	in
L Only	0.0000	in	0.000	ft	0.000	in
S Only	0.0000	in	0.000	ft	0.000	in
W Only	0.0000	in	0.000	ft	0.000	in
E Only	0.0000	in	0.000	ft	0.000	in

Project Title:
Engineer:
Project ID:
Project Descr:

Concrete Column

Project File:

LIC# : KW-06019737, Build:20.25.10.02

PLIRIS

(c) ENERCALC, LLC 1982-2025

DESCRIPTION: GARAGE ENTRY

Sketches

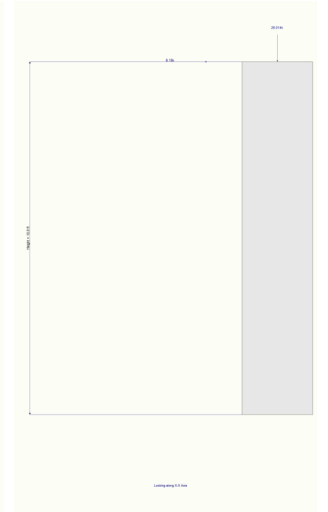
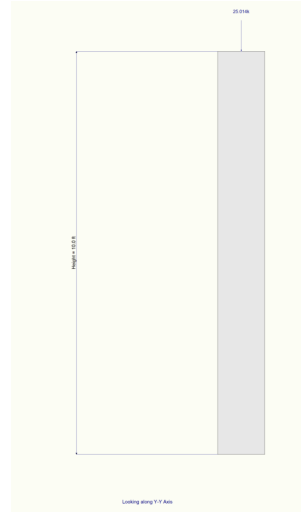
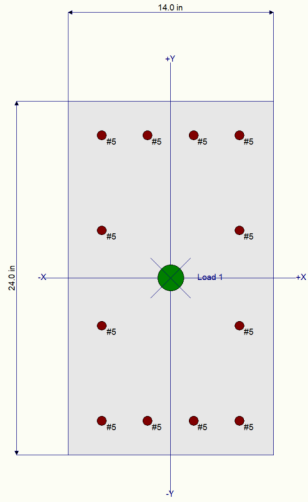

ROOF			
Member Name	Results (Max UTIL %)	Current Solution	Comments
BALCONY RAFTERS	Passed (8% M)	1 piece(s) 2 x 6 DF No.2 @ 16" OC	
BALCONY ROOF BEAM	Passed (81% M)	1 piece(s) 6 x 8 DF No.2	
4TH LEVEL			
Member Name	Results (Max UTIL %)	Current Solution	Comments
3'-FRONT WINDOW	Passed (37% R)	1 piece(s) 4 x 8 DF No.2	
3'/3'/3'- SIDE BALCONY WINDOW/DOOR	Passed (5% R)	1 piece(s) 4 x 8 DF No.2	
4TH LEVEL FLOOR FRAMING			
Member Name	Results (Max UTIL %)	Current Solution	Comments
18.5'-CANT. FLOOR BEAM	Passed (66% R)	1 piece(s) 5 1/2" x 11 7/8" 24F-V4 DF Glulam	
13.25'-FLOOR BEAM	Passed (67% R)	2 piece(s) 1 3/4" x 24" 2.0E Microllam® LVL	
15.5'-FLOOR BEAM	Passed (36% M+)	1 piece(s) 5 1/2" x 11 7/8" 24F-V4 DF Glulam	
15.5'-FLOOR BEAM	Passed (63% ΔT)	1 piece(s) 5 1/2" x 11 7/8" 24F-V4 DF Glulam	
BALCONY FLOOR JOIST	Passed (78% M)	1 piece(s) 2 x 10 DF No.2 @ 16" OC	
3RD LEVEL			
Member Name	Results (Max UTIL %)	Current Solution	Comments
2.5'-FRONT WINDOW (PT LOAD ABV)	Passed (54% M)	1 piece(s) 4 x 8 DF No.2	
3'-FRONT WINDOW	Passed (46% R)	1 piece(s) 4 x 8 DF No.2	
3'-REAR WINDOW	Passed (26% R)	1 piece(s) 4 x 8 DF No.2	
3'/3'/3'- SIDE BALCONY WINDOW/DOOR	Passed (10% R)	1 piece(s) 4 x 8 DF No.2	
14'-FRONT BALCONY BEAM	Passed (101% M)	1 piece(s) 6 x 8 DF No.2	
3'-INTERIOR HEADER	Passed (45% M)	2 piece(s) 2 x 6 DF No.2	
5'-INTERIOR HEADER	Passed (58% M)	1 piece(s) 4 x 8 DF No.2	
3'-FRONT WINDOW (BALCONY)	Passed (41% R)	1 piece(s) 4 x 8 DF No.2	
3RD LEVEL FLOOR FRAMING			
Member Name	Results (Max UTIL %)	Current Solution	Comments
SIDE BALCONY FLOOR JOIST	Passed (78% M)	1 piece(s) 2 x 10 DF No.2 @ 16" OC	
18.5'-CANT. FLOOR BEAM	Passed (66% R)	1 piece(s) 5 1/2" x 11 7/8" 24F-V4 DF Glulam	
15.5'-FLOOR BEAM	Passed (89% R)	1 piece(s) 5 1/2" x 11 7/8" 24F-V4 DF Glulam	
38.25'-FLOOR BEAM (MULTI-SPAN)	Passed (100% M-)	1 piece(s) 5 1/2" x 19 1/2" 24F-V4 DF Glulam	
FRONT BALCONY JOIST	Passed (15% R)	1 piece(s) 2 x 10 DF No.2 @ 16" OC	
FRONT BALCONY BEAM	Passed (72% M)	1 piece(s) 6 x 10 DF No.2	
2ND LEVEL			
Member Name	Results (Max UTIL %)	Current Solution	Comments
2.75'-FRONT WINDOW	Passed (29% R)	1 piece(s) 4 x 8 DF No.2	
3'-FRONT BALCONY WINDOW/DOOR	Passed (35% R)	1 piece(s) 4 x 8 DF No.2	
2.25'-REAR WINDOW	Passed (63% R)	1 piece(s) 4 x 8 DF No.2	
2.25'-REAR WINDOW (PT LD ABV)	Passed (86% V)	1 piece(s) 5 1/2" x 7 1/2" 24F-V4 DF Glulam	
3'/3'/3'- SIDE BALCONY WINDOW/DOOR	Passed (10% R)	1 piece(s) 4 x 8 DF No.2	
2ND LEVEL FLOOR FRAMING			
Member Name	Results (Max UTIL %)	Current Solution	Comments
18.5'-CANT. FLOOR BEAM	Passed (66% R)	1 piece(s) 5 1/2" x 11 7/8" 24F-V4 DF Glulam	
15.5'-FLOOR BEAM	Passed (89% R)	1 piece(s) 5 1/2" x 11 7/8" 24F-V4 DF Glulam	
14'-FLOOR BEAM	Passed (100% R)	1 piece(s) 5 1/2" x 16 1/2" 24F-V4 DF Glulam	
18.5'-FLOOR BEAM	Passed (78% M+)	1 piece(s) 5 1/2" x 16 1/2" 24F-V4 DF Glulam	

Forteweb Software Operator	Job Notes
Royal Mortier PLIRIS (509) 530-8713 royalm@mortierang.com	



ForteWEB Software Operator	Job Notes
Royal Mortier PLIRIS (509) 530-8713 royalm@mortierang.com	



ROOF, BALCONY RAFTERS

1 piece(s) 2 x 6 DF No.2 @ 16" OC

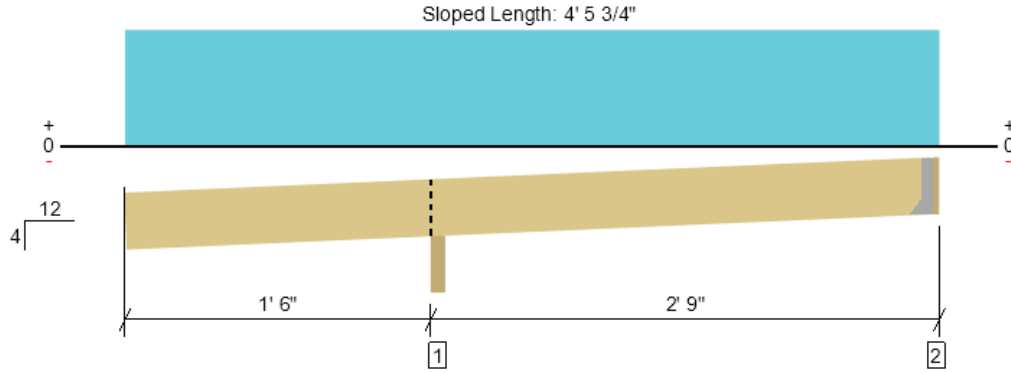

Drawing is Conceptual. All locations are measured from the outside face of left support (or left cantilever end). All dimensions are horizontal (typ.).

Design Results	Actual @ Location	Allowed	Result	LDF	Load: Combination (Pattern)
Member Reaction (lbs)	187 @ 1' 7 3/4"	3459 (3.50")	Passed (5%)	--	1.0 D + 1.0 S (All Spans)
Shear (lbs)	66 @ 2' 2 11/16"	1139	Passed (6%)	1.15	1.0 D + 1.0 S (All Spans)
Moment (Ft-lbs)	-74 @ 1' 7 3/4"	975	Passed (8%)	1.15	1.0 D + 1.0 S (All Spans)
Live Load Defl. (in)	0.004 @ 0	0.200	Passed (2L/999+)	--	1.0 D + 1.0 S (Alt Spans)
Total Load Defl. (in)	0.006 @ 0	0.231	Passed (2L/999+)	--	1.0 D + 1.0 S (Alt Spans)

Member Length : 4' 6"
 System : Roof
 Member Type : Joist
 Building Use : Commercial
 Building Code : IBC 2021
 Design Methodology : ASD
 Member Pitch : 4/12

- Deflection criteria: LL (L/240) and TL (L/180).
- Overhang deflection criteria: LL (0.2") and TL (2L/180).
- Left cantilever length exceeds 1/3 member length or 1/2 back span length. Additional bracing should be considered.
- Allowed moment does not reflect the adjustment for the beam stability factor.
- A 15% increase in the moment capacity has been added to account for repetitive member usage.
- Applicable calculations are based on NDS.

Supports	Bearing Length			Loads to Supports (lbs)				Accessories
	Total	Available	Required	Dead	Roof Live	Snow	Factored	
1 - Beveled Plate - DF	3.50"	3.50"	1.50"	72	92	114	187	Blocking
2 - Hanger on 5 1/2" DF Ledger	1.50"	Hanger ¹	1.50"	17	29	36	53	See note ¹

- Blocking Panels are assumed to carry no loads applied directly above them and the full load is applied to the member being designed.
- At hanger supports, the Total Bearing dimension is equal to the width of the material that is supporting the hanger
- ¹ See Connector grid below for additional information and/or requirements.

Lateral Bracing	Bracing Intervals	Comments
Top Edge (Lu)	4' 4" o/c	
Bottom Edge (Lu)	4' 4" o/c	

- Maximum allowable bracing intervals based on applied load.
- Dimensions for lateral bracing intervals are measured along the length of the member for sloped conditions.

Connector: Simpson Strong-Tie

Support	Model	Seat Length	Top Fasteners	Face Fasteners	Member Fasteners	Accessories
2 - Face Mount Hanger	LRU26Z	1.94"	N/A	4-10dx1.5	5-10d	

- Refer to manufacturer notes and instructions for proper installation and use of all connectors.

Vertical Load	Location (Side)	Spacing	Dead (0.90)	Roof Live (1.25)	Snow (1.15)	Comments
1 - Uniform (PSF)	0 to 4' 3"	16"	15.0	20.0	25.0	ROOF

Weyerhaeuser Notes

Weyerhaeuser warrants that the sizing of its products will be in accordance with Weyerhaeuser product design criteria and published design values. Weyerhaeuser expressly disclaims any other warranties related to the software. Use of this software is not intended to circumvent the need for a design professional as determined by the authority having jurisdiction. The designer of record, builder or framer is responsible to assure that this calculation is compatible with the overall project. Accessories (Rim Board, Blocking Panels and Squash Blocks) are not designed by this software. Products manufactured at Weyerhaeuser facilities are third-party certified to sustainable forestry standards. Weyerhaeuser Engineered Lumber Products have been evaluated by ICC-ES under evaluation reports ESR-1153 and ESR-1387 and/or tested in accordance with applicable ASTM standards. For current code evaluation reports, Weyerhaeuser product literature and installation details refer to www.weyerhaeuser.com/woodproducts/document-library.

The product application, input design loads, dimensions and support information have been provided by ForteWEB Software Operator

ForteWEB Software Operator	Job Notes
Royal Mortier PLIRIS (509) 530-8713 royalm@mortierang.com	

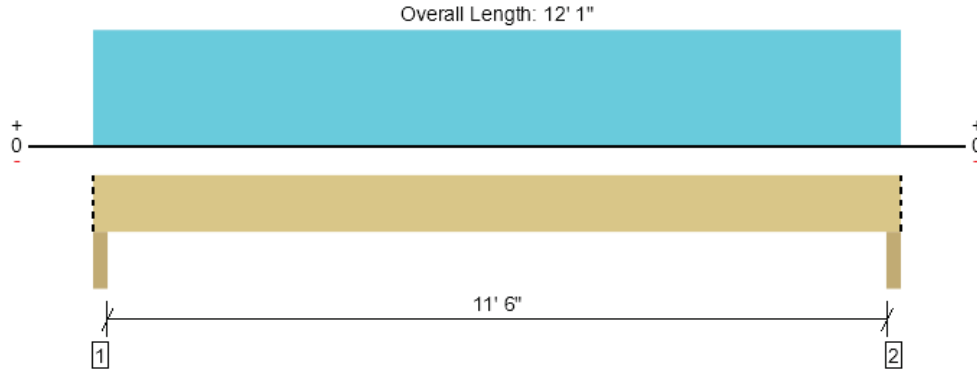

ROOF, BALCONY ROOF BEAM
1 piece(s) 6 x 8 DF No.2

Drawing is Conceptual. All locations are measured from the outside face of left support (or left cantilever end). All dimensions are horizontal (typ.).

Design Results	Actual @ Location	Allowed	Result	LDF	Load: Combination (Pattern)
Member Reaction (lbs)	1045 @ 2"	12031 (3.50")	Passed (9%)	--	1.0 D + 1.0 S (All Spans)
Shear (lbs)	886 @ 11"	5376	Passed (16%)	1.15	1.0 D + 1.0 S (All Spans)
Moment (Ft-lbs)	2985 @ 6' 1/2"	3706	Passed (81%)	1.15	1.0 D + 1.0 S (All Spans)
Live Load Defl. (in)	0.139 @ 6' 1/2"	0.587	Passed (L/999+)	--	1.0 D + 1.0 S (All Spans)
Total Load Defl. (in)	0.295 @ 6' 1/2"	0.783	Passed (L/478)	--	1.0 D + 1.0 S (All Spans)

 Member Length : 12' 1"
 System : Roof
 Member Type : Drop Beam
 Building Use : Commercial
 Building Code : IBC 2021
 Design Methodology : ASD
 Member Pitch : 0/12

- Deflection criteria: LL (L/240) and TL (L/180).
- Allowed moment does not reflect the adjustment for the beam stability factor.
- Applicable calculations are based on NDS.

Supports	Bearing Length			Loads to Supports (lbs)				Accessories
	Total	Available	Required	Dead	Roof Live	Snow	Factored	
1 - Beam - DF	3.50"	3.50"	1.50"	554	393	491	1045	Blocking
2 - Beam - DF	3.50"	3.50"	1.50"	554	393	491	1045	Blocking

- Blocking Panels are assumed to carry no loads applied directly above them and the full load is applied to the member being designed.

Lateral Bracing	Bracing Intervals	Comments
Top Edge (Lu)	12' 1" o/c	
Bottom Edge (Lu)	12' 1" o/c	

- Maximum allowable bracing intervals based on applied load.

Vertical Loads	Location (Side)	Tributary Width	Dead (0.90)	Roof Live (1.25)	Snow (1.15)	Comments
0 - Self Weight (PLF)	0 to 12' 1"	N/A	10.4	--	--	
1 - Uniform (PSF)	0 to 12' 1" (Front)	3' 3"	25.0	20.0	25.0	ROOF

- Side loads are assumed to not induce cross-grain tension.

Weyerhaeuser Notes

Weyerhaeuser warrants that the sizing of its products will be in accordance with Weyerhaeuser product design criteria and published design values. Weyerhaeuser expressly disclaims any other warranties related to the software. Use of this software is not intended to circumvent the need for a design professional as determined by the authority having jurisdiction. The designer of record, builder or framer is responsible to assure that this calculation is compatible with the overall project. Accessories (Rim Board, Blocking Panels and Squash Blocks) are not designed by this software. Products manufactured at Weyerhaeuser facilities are third-party certified to sustainable forestry standards. Weyerhaeuser Engineered Lumber Products have been evaluated by ICC-ES under evaluation reports ESR-1153 and ESR-1387 and/or tested in accordance with applicable ASTM standards. For current code evaluation reports, Weyerhaeuser product literature and installation details refer to www.weyerhaeuser.com/woodproducts/document-library.

The product application, input design loads, dimensions and support information have been provided by ForteWEB Software Operator

ForteWEB Software Operator	Job Notes
Royal Mortier PLIRIS (509) 530-8713 royalm@mortierang.com	



4TH LEVEL, 3'-FRONT WINDOW

1 piece(s) 4 x 8 DF No.2

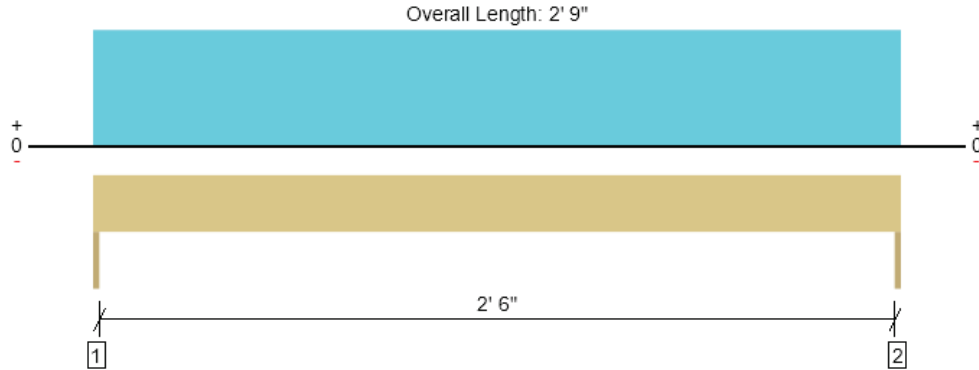

Drawing is Conceptual. All locations are measured from the outside face of left support (or left cantilever end). All dimensions are horizontal (typ.).

Design Results	Actual @ Location	Allowed	Result	LDF	Load: Combination (Pattern)
Member Reaction (lbs)	1228 @ 0	3281 (1.50")	Passed (37%)	--	1.0 D + 1.0 S (All Spans)
Shear (lbs)	577 @ 8 3/4"	3502	Passed (16%)	1.15	1.0 D + 1.0 S (All Spans)
Moment (Ft-lbs)	844 @ 1' 4 1/2"	3438	Passed (25%)	1.15	1.0 D + 1.0 S (All Spans)
Live Load Defl. (in)	0.003 @ 1' 4 1/2"	0.092	Passed (L/999+)	--	1.0 D + 1.0 S (All Spans)
Total Load Defl. (in)	0.006 @ 1' 4 1/2"	0.138	Passed (L/999+)	--	1.0 D + 1.0 S (All Spans)

Member Length : 2' 9"
 System : Wall
 Member Type : Header
 Building Use : Commercial
 Building Code : IBC 2021
 Design Methodology : ASD

- Deflection criteria: LL (L/360) and TL (L/240).
- Allowed moment does not reflect the adjustment for the beam stability factor.
- Applicable calculations are based on NDS.

Supports	Bearing Length			Loads to Supports (lbs)				Accessories
	Total	Available	Required	Dead	Roof Live	Snow	Factored	
1 - Trimmer - DF	1.50"	1.50"	1.50"	635	474	593	1228	None
2 - Trimmer - DF	1.50"	1.50"	1.50"	635	474	593	1228	None

Lateral Bracing	Bracing Intervals	Comments
Top Edge (Lu)	2' 9" o/c	
Bottom Edge (Lu)	2' 9" o/c	

•Maximum allowable bracing intervals based on applied load.

Vertical Loads	Location	Tributary Width	Dead (0.90)	Roof Live (1.25)	Snow (1.15)	Comments
0 - Self Weight (PLF)	0 to 2' 9"	N/A	6.4	--	--	
1 - Uniform (PSF)	0 to 2' 9"	17' 3"	25.0	20.0	25.0	ROOF
2 - Uniform (PSF)	0 to 2' 9"	2'	12.0	--	--	PARAPET

Weyerhaeuser Notes

Weyerhaeuser warrants that the sizing of its products will be in accordance with Weyerhaeuser product design criteria and published design values. Weyerhaeuser expressly disclaims any other warranties related to the software. Use of this software is not intended to circumvent the need for a design professional as determined by the authority having jurisdiction. The designer of record, builder or framer is responsible to assure that this calculation is compatible with the overall project. Accessories (Rim Board, Blocking Panels and Squash Blocks) are not designed by this software. Products manufactured at Weyerhaeuser facilities are third-party certified to sustainable forestry standards. Weyerhaeuser Engineered Lumber Products have been evaluated by ICC-ES under evaluation reports ESR-1153 and ESR-1387 and/or tested in accordance with applicable ASTM standards. For current code evaluation reports, Weyerhaeuser product literature and installation details refer to www.weyerhaeuser.com/woodproducts/document-library.

The product application, input design loads, dimensions and support information have been provided by ForteWEB Software Operator

ForteWEB Software Operator	Job Notes
Royal Mortier PLIRIS (509) 530-8713 royalm@mortierang.com	



4TH LEVEL, 3'³/₃'- SIDE BALCONY WINDOW/DOOR
1 piece(s) 4 x 8 DF No.2

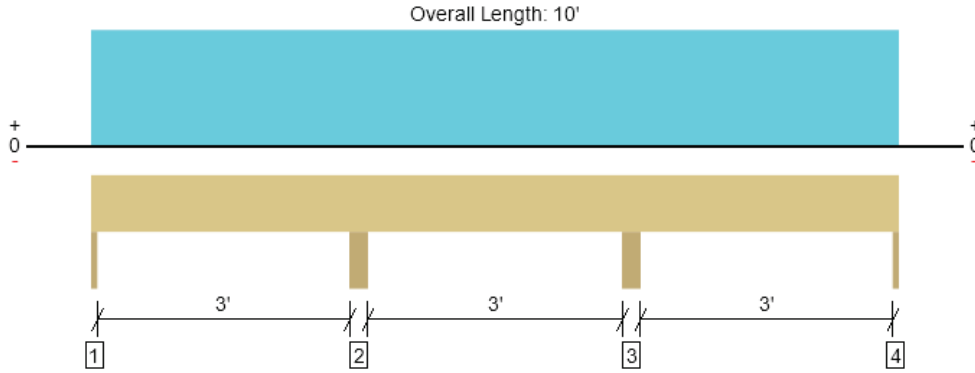

Drawing is Conceptual. All locations are measured from the outside face of left support (or left cantilever end). All dimensions are horizontal (typ.).

Design Results	Actual @ Location	Allowed	Result	LDF	Load: Combination (Pattern)
Member Reaction (lbs)	166 @ 0	3281 (1.50")	Passed (5%)	--	1.0 D + 1.0 S (Alt Spans)
Shear (lbs)	149 @ 2' 6 1/4"	3502	Passed (4%)	1.15	1.0 D + 1.0 S (Adj Spans)
Moment (Ft-lbs)	-141 @ 3' 3 3/4"	3438	Passed (4%)	1.15	1.0 D + 1.0 S (Adj Spans)
Live Load Defl. (in)	0.000 @ 1' 6 7/8"	0.110	Passed (L/999+)	--	1.0 D + 1.0 S (Alt Spans)
Total Load Defl. (in)	0.001 @ 1' 6 7/16"	0.166	Passed (L/999+)	--	1.0 D + 1.0 S (Alt Spans)

Member Length : 10'
 System : Wall
 Member Type : Header
 Building Use : Commercial
 Building Code : IBC 2021
 Design Methodology : ASD

- Deflection criteria: LL (L/360) and TL (L/240).
- Allowed moment does not reflect the adjustment for the beam stability factor.
- Applicable calculations are based on NDS.

Supports	Bearing Length			Loads to Supports (lbs)				Accessories
	Total	Available	Required	Dead	Roof Live	Snow	Factored	
1 - Trimmer - DF	1.50"	1.50"	1.50"	113	42	53	166	None
2 - Trimmer - SPF	4.50"	4.50"	1.50"	316	115	144	460	None
3 - Trimmer - SPF	4.50"	4.50"	1.50"	316	115	144	460	None
4 - Trimmer - DF	1.50"	1.50"	1.50"	113	42	53	166	None

Lateral Bracing	Bracing Intervals	Comments
Top Edge (Lu)	10' o/c	
Bottom Edge (Lu)	10' o/c	

•Maximum allowable bracing intervals based on applied load.

Vertical Loads	Location	Tributary Width	Dead (0.90)	Roof Live (1.25)	Snow (1.15)	Comments
0 - Self Weight (PLF)	0 to 10'	N/A	6.4	--	--	
1 - Uniform (PSF)	0 to 10'	1' 6"	25.0	20.0	25.0	BALCONY ROOF
2 - Uniform (PSF)	0 to 10'	3' 6"	12.0	--	--	PARAPET

Weyerhaeuser Notes

Weyerhaeuser warrants that the sizing of its products will be in accordance with Weyerhaeuser product design criteria and published design values. Weyerhaeuser expressly disclaims any other warranties related to the software. Use of this software is not intended to circumvent the need for a design professional as determined by the authority having jurisdiction. The designer of record, builder or framer is responsible to assure that this calculation is compatible with the overall project. Accessories (Rim Board, Blocking Panels and Squash Blocks) are not designed by this software. Products manufactured at Weyerhaeuser facilities are third-party certified to sustainable forestry standards. Weyerhaeuser Engineered Lumber Products have been evaluated by ICC-ES under evaluation reports ESR-1153 and ESR-1387 and/or tested in accordance with applicable ASTM standards. For current code evaluation reports, Weyerhaeuser product literature and installation details refer to www.weyerhaeuser.com/woodproducts/document-library.

The product application, input design loads, dimensions and support information have been provided by ForteWEB Software Operator

ForteWEB Software Operator	Job Notes
Royal Mortier PLIRIS (509) 530-8713 royalm@mortierang.com	



4TH LEVEL FLOOR FRAMING, 18.5'-CANT. FLOOR BEAM
1 piece(s) 5 1/2" x 11 7/8" 24F-V4 DF Glulam

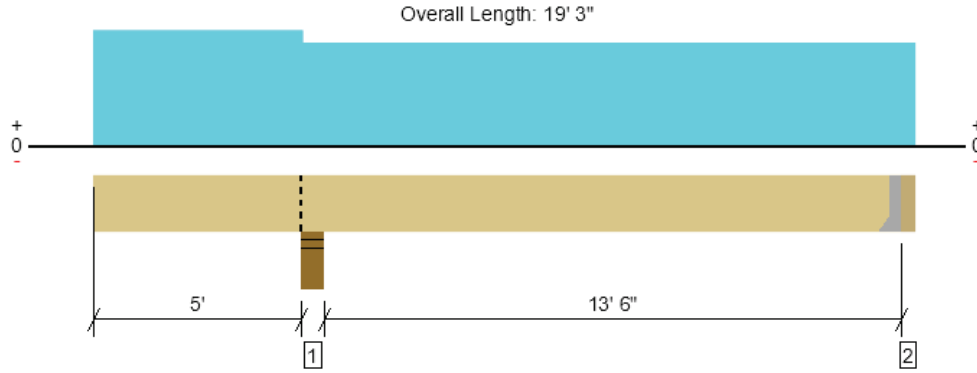

Drawing is Conceptual. All locations are measured from the outside face of left support (or left cantilever end). All dimensions are horizontal (typ.).

Design Results	Actual @ Location	Allowed	Result	LDF	Load: Combination (Pattern)
Member Reaction (lbs)	3534 @ 18' 11 1/2"	5363 (1.50")	Passed (66%)	--	1.0 D + 1.0 L (Alt Spans)
Shear (lbs)	3403 @ 6' 5 3/8"	11539	Passed (29%)	1.00	1.0 D + 1.0 L (All Spans)
Pos Moment (Ft-lbs)	11876 @ 12' 2 7/8"	25853	Passed (46%)	1.00	1.0 D + 1.0 L (Alt Spans)
Neg Moment (Ft-lbs)	-5962 @ 5' 2 3/4"	19928	Passed (30%)	1.00	1.0 D + 1.0 L (All Spans)
Live Load Defl. (in)	0.201 @ 0	0.349	Passed (2L/624)	--	1.0 D + 0.75 L + 0.75 S (Alt Spans)
Total Load Defl. (in)	0.289 @ 12' 1 3/4"	0.686	Passed (L/570)	--	1.0 D + 1.0 L (Alt Spans)

Member Length : 18' 11 1/2"
 System : Floor
 Member Type : Flush Beam
 Building Use : Commercial
 Building Code : IBC 2021
 Design Methodology : ASD

- Deflection criteria: LL (L/360) and TL (L/240).
- Overhang deflection criteria: LL (2L/360) and TL (2L/240).
- Allowed moment does not reflect the adjustment for the beam stability factor.
- Volume factor of 1.00 was calculated for positive bending using length L = 13' 5 5/16".
- Volume factor of 1.00 was calculated for negative bending using length L = 6' 10 9/16".
- The effects of positive or negative camber have not been accounted for when calculating deflection.
- The specified glulam is assumed to have its strong laminations at the bottom of the beam. Install with proper side up as indicated by the manufacturer.
- Applicable calculations are based on NDS.

Supports	Bearing Length			Loads to Supports (lbs)				Accessories
	Total	Available	Required	Dead	Floor Live	Snow	Factored	
1 - Stud wall - DF	5.50"	5.50"	1.85"	1774	4570	899	6344	Blocking
2 - Hanger on 11 7/8" DF beam	3.50"	Hanger ¹	1.50"	1250	2433/-259	-149	3683	See note ¹

- Blocking Panels are assumed to carry no loads applied directly above them and the full load is applied to the member being designed.
- At hanger supports, the Total Bearing dimension is equal to the width of the material that is supporting the hanger
- ¹ See Connector grid below for additional information and/or requirements.

Lateral Bracing	Bracing Intervals	Comments
Top Edge (Lu)	19' o/c	
Bottom Edge (Lu)	19' o/c	

•Maximum allowable bracing intervals based on applied load.

Connector: Simpson Strong-Tie

Support	Model	Seat Length	Top Fasteners	Face Fasteners	Member Fasteners	Accessories
2 - Face Mount Hanger	HU614	2.50"	N/A	24-16d	12-16d	

• Refer to manufacturer notes and instructions for proper installation and use of all connectors.

Vertical Loads	Location (Side)	Tributary Width	Dead (0.90)	Floor Live (1.00)	Snow (1.15)	Comments
0 - Self Weight (PLF)	0 to 18' 11 1/2"	N/A	15.9	--	--	
1 - Uniform (PSF)	0 to 5' (Front)	6'	10.0	60.0	25.0	BALCONY
2 - Uniform (PSF)	5' to 19' 3" (Front)	8' 6"	20.0	40.0	--	FLOOR

• Side loads are assumed to not induce cross-grain tension.

FortewEB Software Operator	Job Notes
Royal Mortier PLIRIS (509) 530-8713 royalm@mortierang.com	



Weyerhaeuser Notes

Weyerhaeuser warrants that the sizing of its products will be in accordance with Weyerhaeuser product design criteria and published design values. Weyerhaeuser expressly disclaims any other warranties related to the software. Use of this software is not intended to circumvent the need for a design professional as determined by the authority having jurisdiction. The designer of record, builder or framer is responsible to assure that this calculation is compatible with the overall project. Accessories (Rim Board, Blocking Panels and Squash Blocks) are not designed by this software. Products manufactured at Weyerhaeuser facilities are third-party certified to sustainable forestry standards. Weyerhaeuser Engineered Lumber Products have been evaluated by ICC-ES under evaluation reports ESR-1153 and ESR-1387 and/or tested in accordance with applicable ASTM standards. For current code evaluation reports, Weyerhaeuser product literature and installation details refer to www.weyerhaeuser.com/woodproducts/document-library.

The product application, input design loads, dimensions and support information have been provided by ForteWEB Software Operator

ForteWEB Software Operator	Job Notes
Royal Mortier PLIRIS (509) 530-8713 royalm@mortierang.com	



4TH LEVEL FLOOR FRAMING, 13.25'-FLOOR BEAM
2 piece(s) 1 3/4" x 24" 2.0E Microllam® LVL

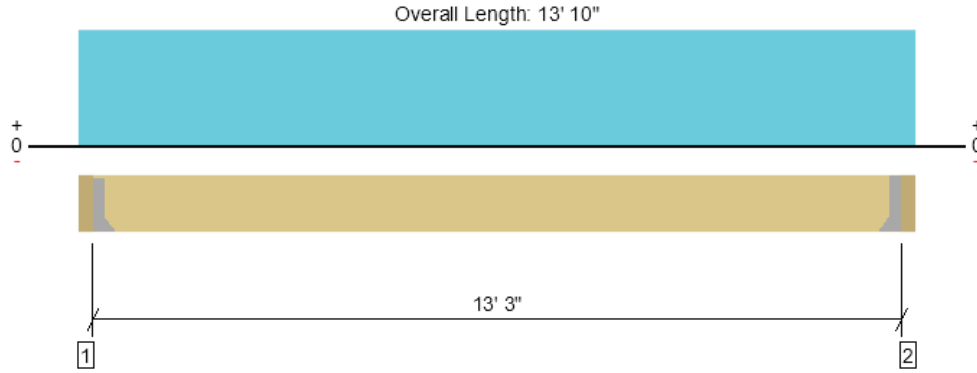

Drawing is Conceptual. All locations are measured from the outside face of left support (or left cantilever end). All dimensions are horizontal (typ.).

Design Results	Actual @ Location	Allowed	Result	LDF	Load: Combination (Pattern)
Member Reaction (lbs)	2647 @ 3 1/2"	3938 (1.50")	Passed (67%)	--	1.0 D + 1.0 L (All Spans)
Shear (lbs)	1848 @ 2' 3 1/2"	15960	Passed (12%)	1.00	1.0 D + 1.0 L (All Spans)
Moment (Ft-lbs)	8767 @ 6' 11"	66251	Passed (13%)	1.00	1.0 D + 1.0 L (All Spans)
Live Load Defl. (in)	0.029 @ 6' 11"	0.442	Passed (L/999+)	--	1.0 D + 1.0 L (All Spans)
Total Load Defl. (in)	0.046 @ 6' 11"	0.663	Passed (L/999+)	--	1.0 D + 1.0 L (All Spans)

Member Length : 13' 3"
 System : Floor
 Member Type : Flush Beam
 Building Use : Commercial
 Building Code : IBC 2021
 Design Methodology : ASD

- Deflection criteria: LL (L/360) and TL (L/240).
- Allowed moment does not reflect the adjustment for the beam stability factor.

Supports	Bearing Length			Loads to Supports (lbs)			Accessories
	Total	Available	Required	Dead	Floor Live	Factored	
1 - Hanger on 24" DF beam	3.50"	Hanger ¹	1.50"	1027	1729	2756	See note ¹
2 - Hanger on 24" DF beam	3.50"	Hanger ¹	1.50"	1027	1729	2756	See note ¹

- At hanger supports, the Total Bearing dimension is equal to the width of the material that is supporting the hanger
- ¹ See Connector grid below for additional information and/or requirements.

Lateral Bracing	Bracing Intervals	Comments
Top Edge (Lu)	13' 3" o/c	
Bottom Edge (Lu)	13' 3" o/c	

- Maximum allowable bracing intervals based on applied load.

Connector: Simpson Strong-Tie							
Support	Model	Seat Length	Top Fasteners	Face Fasteners	Member Fasteners	Accessories	
1 - Face Mount Hanger	THA426	1.75"	N/A	30-16d	6-16d		
2 - Face Mount Hanger	THA426	1.75"	N/A	30-16d	6-16d		

- Refer to manufacturer notes and instructions for proper installation and use of all connectors.

Vertical Loads	Location (Side)	Tributary Width	Dead (0.90)	Floor Live (1.00)	Comments
0 - Self Weight (PLF)	3 1/2" to 13' 6 1/2"	N/A	24.5	--	
1 - Uniform (PSF)	0 to 13' 10" (Front)	6' 3"	20.0	40.0	FLOOR

- Side loads are assumed to not induce cross-grain tension.

Weyerhaeuser Notes

Weyerhaeuser warrants that the sizing of its products will be in accordance with Weyerhaeuser product design criteria and published design values. Weyerhaeuser expressly disclaims any other warranties related to the software. Use of this software is not intended to circumvent the need for a design professional as determined by the authority having jurisdiction. The designer of record, builder or framer is responsible to assure that this calculation is compatible with the overall project. Accessories (Rim Board, Blocking Panels and Squash Blocks) are not designed by this software. Products manufactured at Weyerhaeuser facilities are third-party certified to sustainable forestry standards. Weyerhaeuser Engineered Lumber Products have been evaluated by ICC-ES under evaluation reports ESR-1153 and ESR-1387 and/or tested in accordance with applicable ASTM standards. For current code evaluation reports, Weyerhaeuser product literature and installation details refer to www.weyerhaeuser.com/woodproducts/document-library.

The product application, input design loads, dimensions and support information have been provided by ForteWEB Software Operator

ForteWEB Software Operator	Job Notes
Royal Mortier PLIRIS (509) 530-8713 royalm@mortierang.com	



4TH LEVEL FLOOR FRAMING, 15.5'-FLOOR BEAM
1 piece(s) 5 1/2" x 11 7/8" 24F-V4 DF Glulam

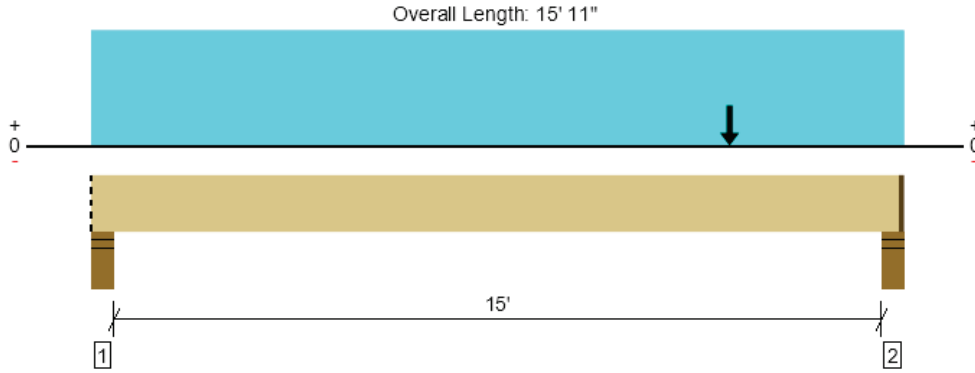

Drawing is Conceptual. All locations are measured from the outside face of left support (or left cantilever end). All dimensions are horizontal (typ.).

Design Results	Actual @ Location	Allowed	Result	LDF	Load: Combination (Pattern)
Member Reaction (lbs)	3225 @ 15' 7"	14609 (4.25")	Passed (22%)	--	1.0 D + 1.0 L (All Spans)
Shear (lbs)	3043 @ 14' 5 5/8"	11539	Passed (26%)	1.00	1.0 D + 1.0 L (All Spans)
Pos Moment (Ft-lbs)	9221 @ 11' 11 13/16"	25853	Passed (36%)	1.00	1.0 D + 1.0 L (All Spans)
Live Load Defl. (in)	0.163 @ 8' 5 15/16"	0.508	Passed (L/999+)	--	1.0 D + 1.0 L (All Spans)
Total Load Defl. (in)	0.265 @ 8' 5 11/16"	0.762	Passed (L/692)	--	1.0 D + 1.0 L (All Spans)

Member Length : 15' 9 3/4"
 System : Floor
 Member Type : Flush Beam
 Building Use : Commercial
 Building Code : IBC 2021
 Design Methodology : ASD

- Deflection criteria: LL (L/360) and TL (L/240).
- Allowed moment does not reflect the adjustment for the beam stability factor.
- Volume factor of 1.00 was calculated for positive bending using length L = 15' 3".
- The effects of positive or negative camber have not been accounted for when calculating deflection.
- The specified glulam is assumed to have its strong laminations at the bottom of the beam. Install with proper side up as indicated by the manufacturer.
- Applicable calculations are based on NDS.

Supports	Bearing Length			Loads to Supports (lbs)			Accessories
	Total	Available	Required	Dead	Floor Live	Factored	
1 - Stud wall - DF	5.50"	5.50"	1.50"	642	986	1628	Blocking
2 - Stud wall - DF	5.50"	4.25"	1.50"	1221	2017	3238	1 1/4" Rim Board

- Rim Board is assumed to carry all loads applied directly above it, bypassing the member being designed.
- Blocking Panels are assumed to carry no loads applied directly above them and the full load is applied to the member being designed.

Lateral Bracing	Bracing Intervals	Comments
Top Edge (Lu)	15' 10" o/c	
Bottom Edge (Lu)	15' 10" o/c	

- Maximum allowable bracing intervals based on applied load.

Vertical Loads	Location (Side)	Tributary Width	Dead (0.90)	Floor Live (1.00)	Comments
0 - Self Weight (PLF)	0 to 15' 9 3/4"	N/A	15.9	--	
1 - Point (lb)	12' 6" (Front)	N/A	975	1730	13.25'-FLOOR BEAM
2 - Uniform (PSF)	0 to 15' 11" (Front)	2'	20.0	40.0	FLOOR

- Side loads are assumed to not induce cross-grain tension.

Weyerhaeuser Notes

Weyerhaeuser warrants that the sizing of its products will be in accordance with Weyerhaeuser product design criteria and published design values. Weyerhaeuser expressly disclaims any other warranties related to the software. Use of this software is not intended to circumvent the need for a design professional as determined by the authority having jurisdiction. The designer of record, builder or framer is responsible to assure that this calculation is compatible with the overall project. Accessories (Rim Board, Blocking Panels and Squash Blocks) are not designed by this software. Products manufactured at Weyerhaeuser facilities are third-party certified to sustainable forestry standards. Weyerhaeuser Engineered Lumber Products have been evaluated by ICC-ES under evaluation reports ESR-1153 and ESR-1387 and/or tested in accordance with applicable ASTM standards. For current code evaluation reports, Weyerhaeuser product literature and installation details refer to www.weyerhaeuser.com/woodproducts/document-library.

The product application, input design loads, dimensions and support information have been provided by ForteWEB Software Operator

ForteWEB Software Operator	Job Notes
Royal Mortier PLIRIS (509) 530-8713 royalm@mortierang.com	



4TH LEVEL FLOOR FRAMING, 15.5'-FLOOR BEAM
1 piece(s) 5 1/2" x 11 7/8" 24F-V4 DF Glulam

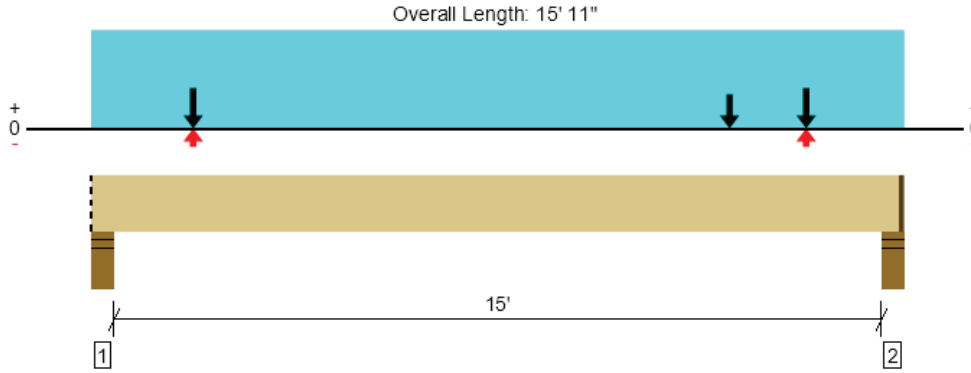

Drawing is Conceptual. All locations are measured from the outside face of left support (or left cantilever end). All dimensions are horizontal (typ.).

Design Results	Actual @ Location	Allowed	Result	LDF	Load: Combination (Pattern)
Member Reaction (lbs)	6935 @ 15' 7"	14609 (4.25")	Passed (47%)	--	1.0 D + 1.0 L (All Spans)
Shear (lbs)	6753 @ 14' 5 5/8"	11539	Passed (59%)	1.00	1.0 D + 1.0 L (All Spans)
Pos Moment (Ft-lbs)	15137 @ 11' 10"	25853	Passed (59%)	1.00	1.0 D + 1.0 L (All Spans)
Live Load Defl. (in)	0.305 @ 8' 3"	0.508	Passed (L/601)	--	1.0 D + 1.0 L (All Spans)
Total Load Defl. (in)	0.479 @ 8' 2 15/16"	0.762	Passed (L/382)	--	1.0 D + 1.0 L (All Spans)

Member Length : 15' 9 3/4"
 System : Floor
 Member Type : Flush Beam
 Building Use : Commercial
 Building Code : IBC 2021
 Design Methodology : ASD

- Deflection criteria: LL (L/360) and TL (L/240).
- Allowed moment does not reflect the adjustment for the beam stability factor.
- Volume factor of 1.00 was calculated for positive bending using length L = 15' 3".
- The effects of positive or negative camber have not been accounted for when calculating deflection.
- The specified glulam is assumed to have its strong laminations at the bottom of the beam. Install with proper side up as indicated by the manufacturer.
- Applicable calculations are based on NDS.

Supports	Bearing Length			Loads to Supports (lbs)				Accessories
	Total	Available	Required	Dead	Floor Live	Snow	Factored	
1 - Stud wall - DF	5.50"	5.50"	1.54"	1885	3413	-149	5298	Blocking
2 - Stud wall - DF	5.50"	4.25"	2.02"	2478	4470	-151	6948	1 1/4" Rim Board

- Rim Board is assumed to carry all loads applied directly above it, bypassing the member being designed.
- Blocking Panels are assumed to carry no loads applied directly above them and the full load is applied to the member being designed.

Lateral Bracing	Bracing Intervals	Comments
Top Edge (Lu)	15' 10" o/c	
Bottom Edge (Lu)	15' 10" o/c	

- Maximum allowable bracing intervals based on applied load.

Vertical Loads	Location (Side)	Tributary Width	Dead (0.90)	Floor Live (1.00)	Snow (1.15)	Comments
0 - Self Weight (PLF)	0 to 15' 9 3/4"	N/A	15.9	--	--	
1 - Point (lb)	2' (Back)	N/A	1250	2440	-150	18.5'-CANT. FLOOR BEAM
2 - Point (lb)	14' (Back)	N/A	1250	2440	-150	18.5'-CANT. FLOOR BEAM
3 - Point (lb)	12' 6" (Front)	N/A	975	1730	--	13.25'-FLOOR BEAM
4 - Uniform (PSF)	0 to 15' 11" (Front)	2'	20.0	40.0	--	FLOOR

- Side loads are assumed to not induce cross-grain tension.

Weyerhaeuser Notes

Weyerhaeuser warrants that the sizing of its products will be in accordance with Weyerhaeuser product design criteria and published design values. Weyerhaeuser expressly disclaims any other warranties related to the software. Use of this software is not intended to circumvent the need for a design professional as determined by the authority having jurisdiction. The designer of record, builder or framer is responsible to assure that this calculation is compatible with the overall project. Accessories (Rim Board, Blocking Panels and Squash Blocks) are not designed by this software. Products manufactured at Weyerhaeuser facilities are third-party certified to sustainable forestry standards. Weyerhaeuser Engineered Lumber Products have been evaluated by ICC-ES under evaluation reports ESR-1153 and ESR-1387 and/or tested in accordance with applicable ASTM standards. For current code evaluation reports, Weyerhaeuser product literature and installation details refer to www.woyerhaeuser.com/woodproducts/document-library.

The product application, input design loads, dimensions and support information have been provided by ForteWEB Software Operator

ForteWEB Software Operator	Job Notes
Royal Mortier PLIRIS (509) 530-8713 royalm@mortierang.com	



4TH LEVEL FLOOR FRAMING, BALCONY FLOOR JOIST
1 piece(s) 2 x 10 DF No.2 @ 16" OC

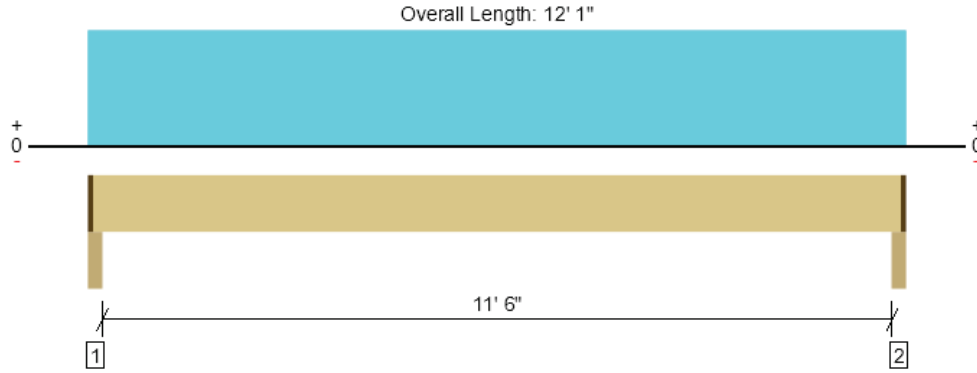

Drawing is Conceptual. All locations are measured from the outside face of left support (or left cantilever end). All dimensions are horizontal (typ.).

Design Results	Actual @ Location	Allowed	Result	LDF	Load: Combination (Pattern)
Member Reaction (lbs)	584 @ 2 1/2"	2109 (2.25")	Passed (28%)	--	1.0 D + 0.75 L + 0.75 S (All Spans)
Shear (lbs)	465 @ 1' 3/4"	1665	Passed (28%)	1.00	1.0 D + 1.0 L (All Spans)
Moment (Ft-lbs)	1588 @ 6' 1/2"	2029	Passed (78%)	1.00	1.0 D + 1.0 L (All Spans)
Live Load Defl. (in)	0.224 @ 6' 1/2"	0.292	Passed (L/625)	--	1.0 D + 0.75 L + 0.75 S (All Spans)
Total Load Defl. (in)	0.259 @ 6' 1/2"	0.583	Passed (L/541)	--	1.0 D + 0.75 L + 0.75 S (All Spans)
TJ-Pro™ Rating	N/A	N/A	N/A	--	N/A

Member Length : 11' 10 1/2"
 System : Floor
 Member Type : Joist
 Building Use : Commercial
 Building Code : IBC 2021
 Design Methodology : ASD

- Deflection criteria: LL (L/480) and TL (L/240).
- Allowed moment does not reflect the adjustment for the beam stability factor.
- A 15% increase in the moment capacity has been added to account for repetitive member usage.
- Applicable calculations are based on NDS.
- No composite action between deck and joist was considered in analysis.

Supports	Bearing Length			Loads to Supports (lbs)				Accessories
	Total	Available	Required	Dead	Floor Live	Snow	Factored	
1 - Beam - DF	3.50"	2.25"	1.50"	81	483	201	594	1 1/4" Rim Board
2 - Beam - DF	3.50"	2.25"	1.50"	81	483	201	594	1 1/4" Rim Board

• Rim Board is assumed to carry all loads applied directly above it, bypassing the member being designed.

Lateral Bracing	Bracing Intervals	Comments
Top Edge (Lu)	6' 9" o/c	
Bottom Edge (Lu)	11' 11" o/c	

•Maximum allowable bracing intervals based on applied load.

Vertical Load	Location (Side)	Spacing	Dead (0.90)	Floor Live (1.00)	Snow (1.15)	Comments
1 - Uniform (PSF)	0 to 12' 1"	16"	10.0	60.0	25.0	BALCONY

Weyerhaeuser Notes

Weyerhaeuser warrants that the sizing of its products will be in accordance with Weyerhaeuser product design criteria and published design values. Weyerhaeuser expressly disclaims any other warranties related to the software. Use of this software is not intended to circumvent the need for a design professional as determined by the authority having jurisdiction. The designer of record, builder or framer is responsible to assure that this calculation is compatible with the overall project. Accessories (Rim Board, Blocking Panels and Squash Blocks) are not designed by this software. Products manufactured at Weyerhaeuser facilities are third-party certified to sustainable forestry standards. Weyerhaeuser Engineered Lumber Products have been evaluated by ICC-ES under evaluation reports ESR-1153 and ESR-1387 and/or tested in accordance with applicable ASTM standards. For current code evaluation reports, Weyerhaeuser product literature and installation details refer to www.weyerhaeuser.com/woodproducts/document-library.

The product application, input design loads, dimensions and support information have been provided by ForteWEB Software Operator

ForteWEB Software Operator	Job Notes
Royal Mortier PLIRIS (509) 530-8713 royalm@mortierang.com	



3RD LEVEL, 2.5'-FRONT WINDOW (PT LOAD ABV)
1 piece(s) 4 x 8 DF No.2

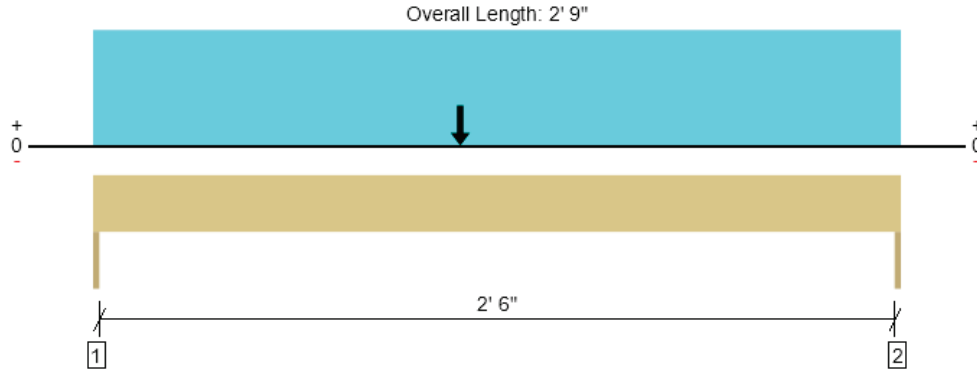

Drawing is Conceptual. All locations are measured from the outside face of left support (or left cantilever end). All dimensions are horizontal (typ.).

Design Results	Actual @ Location	Allowed	Result	LDF	Load: Combination (Pattern)
Member Reaction (lbs)	1760 @ 0	3281 (1.50")	Passed (54%)	--	1.0 D + 0.75 L + 0.75 S (All Spans)
Shear (lbs)	1458 @ 8 3/4"	3502	Passed (42%)	1.15	1.0 D + 1.0 S (All Spans)
Moment (Ft-lbs)	1872 @ 1' 3"	3438	Passed (54%)	1.15	1.0 D + 0.75 L + 0.75 S (All Spans)
Live Load Defl. (in)	0.006 @ 1' 4 7/16"	0.092	Passed (L/999+)	--	1.0 D + 0.75 L + 0.75 S (All Spans)
Total Load Defl. (in)	0.012 @ 1' 4 3/8"	0.138	Passed (L/999+)	--	1.0 D + 0.75 L + 0.75 S (All Spans)

Member Length : 2' 9"
 System : Wall
 Member Type : Header
 Building Use : Commercial
 Building Code : IBC 2021
 Design Methodology : ASD

- Deflection criteria: LL (L/360) and TL (L/240).
- Allowed moment does not reflect the adjustment for the beam stability factor.
- Applicable calculations are based on NDS.

Supports	Bearing Length			Loads to Supports (lbs)					Accessories
	Total	Available	Required	Dead	Floor Live	Roof Live	Snow	Factored	
1 - Trimmer - DF	1.50"	1.50"	1.50"	928	454	518	655	1760	None
2 - Trimmer - DF	1.50"	1.50"	1.50"	813	454	432	545	1562	None

Lateral Bracing	Bracing Intervals	Comments
Top Edge (Lu)	2' 9" o/c	
Bottom Edge (Lu)	2' 9" o/c	

•Maximum allowable bracing intervals based on applied load.

Vertical Loads	Location	Tributary Width	Dead (0.90)	Floor Live (1.00)	Roof Live (1.25)	Snow (1.15)	Comments
0 - Self Weight (PLF)	0 to 2' 9"	N/A	6.4	--	--	--	
1 - Point (lb)	1' 3"	N/A	635	--	475	600	3'-FRONT WINDOW
2 - Point (lb)	1' 3"	N/A	635	--	475	600	3'-FRONT WINDOW
3 - Uniform (PSF)	0 to 2' 9"	8' 3"	20.0	40.0	--	--	4TH LEVEL FLOOR

Weyerhaeuser Notes

Weyerhaeuser warrants that the sizing of its products will be in accordance with Weyerhaeuser product design criteria and published design values. Weyerhaeuser expressly disclaims any other warranties related to the software. Use of this software is not intended to circumvent the need for a design professional as determined by the authority having jurisdiction. The designer of record, builder or framer is responsible to assure that this calculation is compatible with the overall project. Accessories (Rim Board, Blocking Panels and Squash Blocks) are not designed by this software. Products manufactured at Weyerhaeuser facilities are third-party certified to sustainable forestry standards. Weyerhaeuser Engineered Lumber Products have been evaluated by ICC-ES under evaluation reports ESR-1153 and ESR-1387 and/or tested in accordance with applicable ASTM standards. For current code evaluation reports, Weyerhaeuser product literature and installation details refer to www.weyerhaeuser.com/woodproducts/document-library.

The product application, input design loads, dimensions and support information have been provided by ForteWEB Software Operator

ForteWEB Software Operator	Job Notes
Royal Mortier PLIRIS (509) 530-8713 royalm@mortierang.com	



3RD LEVEL, 3'-FRONT WINDOW
1 piece(s) 4 x 8 DF No.2

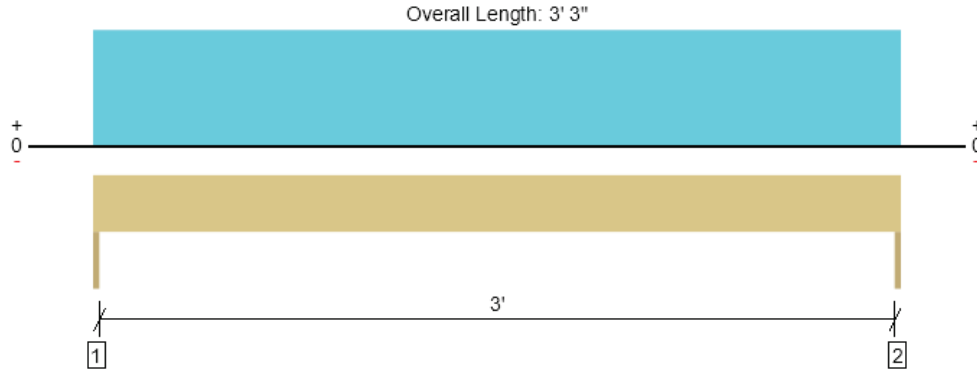

Drawing is Conceptual. All locations are measured from the outside face of left support (or left cantilever end). All dimensions are horizontal (typ.).

Design Results	Actual @ Location	Allowed	Result	LDF	Load: Combination (Pattern)
Member Reaction (lbs)	1506 @ 0	3281 (1.50")	Passed (46%)	--	1.0 D + 1.0 S (All Spans)
Shear (lbs)	830 @ 8 3/4"	3502	Passed (24%)	1.15	1.0 D + 1.0 S (All Spans)
Moment (Ft-lbs)	1224 @ 1' 7 1/2"	3438	Passed (36%)	1.15	1.0 D + 1.0 S (All Spans)
Live Load Defl. (in)	0.006 @ 1' 7 1/2"	0.108	Passed (L/999+)	--	1.0 D + 1.0 S (All Spans)
Total Load Defl. (in)	0.013 @ 1' 7 1/2"	0.162	Passed (L/999+)	--	1.0 D + 1.0 S (All Spans)

Member Length : 3' 3"
 System : Wall
 Member Type : Header
 Building Use : Commercial
 Building Code : IBC 2021
 Design Methodology : ASD

- Deflection criteria: LL (L/360) and TL (L/240).
- Allowed moment does not reflect the adjustment for the beam stability factor.
- Applicable calculations are based on NDS.

Supports	Bearing Length			Loads to Supports (lbs)				Accessories
	Total	Available	Required	Dead	Roof Live	Snow	Factored	
1 - Trimmer - DF	1.50"	1.50"	1.50"	846	528	660	1506	None
2 - Trimmer - DF	1.50"	1.50"	1.50"	846	528	660	1506	None

Lateral Bracing	Bracing Intervals	Comments
Top Edge (Lu)	3' 3" o/c	
Bottom Edge (Lu)	3' 3" o/c	

•Maximum allowable bracing intervals based on applied load.

Vertical Loads	Location	Tributary Width	Dead (0.90)	Roof Live (1.25)	Snow (1.15)	Comments
0 - Self Weight (PLF)	0 to 3' 3"	N/A	6.4	--	--	
1 - Uniform (PSF)	0 to 3' 3"	16' 3"	25.0	20.0	25.0	ROOF
2 - Uniform (PSF)	0 to 3' 3"	2'	--	--	--	PARAPET
3 - Uniform (PSF)	0 to 3' 3"	9'	12.0	--	--	WALL

Weyerhaeuser Notes

Weyerhaeuser warrants that the sizing of its products will be in accordance with Weyerhaeuser product design criteria and published design values. Weyerhaeuser expressly disclaims any other warranties related to the software. Use of this software is not intended to circumvent the need for a design professional as determined by the authority having jurisdiction. The designer of record, builder or framer is responsible to assure that this calculation is compatible with the overall project. Accessories (Rim Board, Blocking Panels and Squash Blocks) are not designed by this software. Products manufactured at Weyerhaeuser facilities are third-party certified to sustainable forestry standards. Weyerhaeuser Engineered Lumber Products have been evaluated by ICC-ES under evaluation reports ESR-1153 and ESR-1387 and/or tested in accordance with applicable ASTM standards. For current code evaluation reports, Weyerhaeuser product literature and installation details refer to www.weyerhaeuser.com/woodproducts/document-library.

The product application, input design loads, dimensions and support information have been provided by ForteWEB Software Operator

ForteWEB Software Operator	Job Notes
Royal Mortier PLIRIS (509) 530-8713 royalm@mortierang.com	

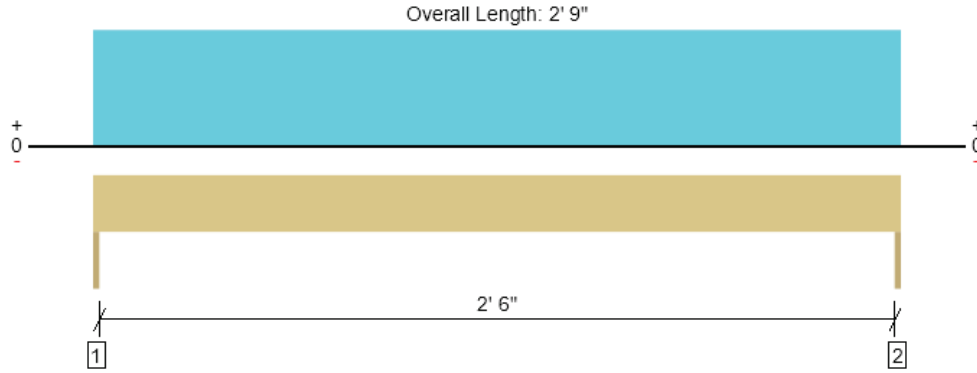

3RD LEVEL, 3'-REAR WINDOW

1 piece(s) 4 x 8 DF No.2

Drawing is Conceptual. All locations are measured from the outside face of left support (or left cantilever end). All dimensions are horizontal (typ.).

Design Results	Actual @ Location	Allowed	Result	LDF	Load: Combination (Pattern)
Member Reaction (lbs)	838 @ 0	3281 (1.50")	Passed (26%)	--	1.0 D + 1.0 L (All Spans)
Shear (lbs)	394 @ 8 3/4"	3045	Passed (13%)	1.00	1.0 D + 1.0 L (All Spans)
Moment (Ft-lbs)	576 @ 1' 4 1/2"	2989	Passed (19%)	1.00	1.0 D + 1.0 L (All Spans)
Live Load Defl. (in)	0.002 @ 1' 4 1/2"	0.092	Passed (L/999+)	--	1.0 D + 1.0 L (All Spans)
Total Load Defl. (in)	0.004 @ 1' 4 1/2"	0.138	Passed (L/999+)	--	1.0 D + 1.0 L (All Spans)

 Member Length : 2' 9"
 System : Wall
 Member Type : Header
 Building Use : Commercial
 Building Code : IBC 2021
 Design Methodology : ASD

- Deflection criteria: LL (L/360) and TL (L/240).
- Allowed moment does not reflect the adjustment for the beam stability factor.
- Applicable calculations are based on NDS.

Supports	Bearing Length			Loads to Supports (lbs)			Accessories
	Total	Available	Required	Dead	Floor Live	Factored	
1 - Trimmer - DF	1.50"	1.50"	1.50"	384	454	838	None
2 - Trimmer - DF	1.50"	1.50"	1.50"	384	454	838	None

Lateral Bracing	Bracing Intervals	Comments
Top Edge (Lu)	2' 9" o/c	
Bottom Edge (Lu)	2' 9" o/c	

•Maximum allowable bracing intervals based on applied load.

Vertical Loads	Location	Tributary Width	Dead (0.90)	Floor Live (1.00)	Comments
0 - Self Weight (PLF)	0 to 2' 9"	N/A	6.4	--	
1 - Uniform (PSF)	0 to 2' 9"	8' 3"	20.0	40.0	4TH LEVEL FLOOR
2 - Uniform (PSF)	0 to 2' 9"	9'	12.0	--	4TH LEVEL WALL

Weyerhaeuser Notes

Weyerhaeuser warrants that the sizing of its products will be in accordance with Weyerhaeuser product design criteria and published design values. Weyerhaeuser expressly disclaims any other warranties related to the software. Use of this software is not intended to circumvent the need for a design professional as determined by the authority having jurisdiction. The designer of record, builder or framer is responsible to assure that this calculation is compatible with the overall project. Accessories (Rim Board, Blocking Panels and Squash Blocks) are not designed by this software. Products manufactured at Weyerhaeuser facilities are third-party certified to sustainable forestry standards. Weyerhaeuser Engineered Lumber Products have been evaluated by ICC-ES under evaluation reports ESR-1153 and ESR-1387 and/or tested in accordance with applicable ASTM standards. For current code evaluation reports, Weyerhaeuser product literature and installation details refer to www.weyerhaeuser.com/woodproducts/document-library.

The product application, input design loads, dimensions and support information have been provided by ForteWEB Software Operator

ForteWEB Software Operator	Job Notes
Royal Mortier PLIRIS (509) 530-8713 royalm@mortierang.com	



3RD LEVEL, 3'3/3'- SIDE BALCONY WINDOW/DOOR
1 piece(s) 4 x 8 DF No.2

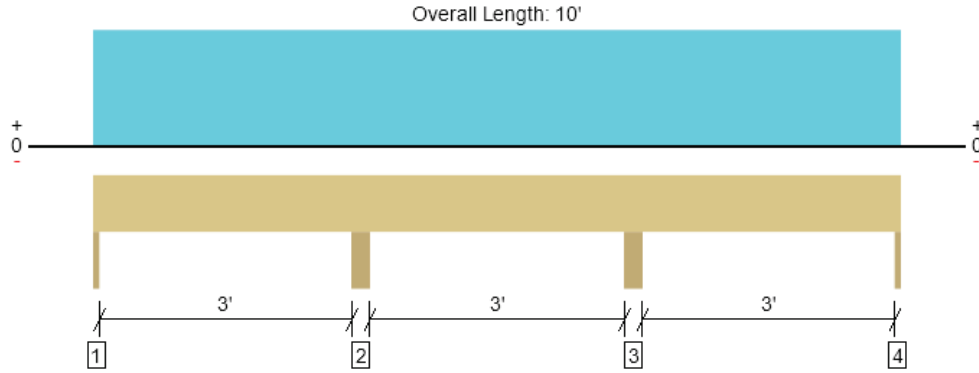

Drawing is Conceptual. All locations are measured from the outside face of left support (or left cantilever end). All dimensions are horizontal (typ.).

Design Results	Actual @ Location	Allowed	Result	LDF	Load: Combination (Pattern)
Member Reaction (lbs)	323 @ 0	3281 (1.50")	Passed (10%)	--	1.0 D + 1.0 L (Alt Spans)
Shear (lbs)	286 @ 2' 6 1/4"	3045	Passed (9%)	1.00	1.0 D + 1.0 L (Adj Spans)
Moment (Ft-lbs)	-276 @ 1' 7 5/16"	2989	Passed (9%)	1.00	1.0 D + 1.0 L (Adj Spans)
Live Load Defl. (in)	0.001 @ 1' 7 5/16"	0.110	Passed (L/999+)	--	1.0 D + 1.0 L (Alt Spans)
Total Load Defl. (in)	0.002 @ 8' 5 5/16"	0.166	Passed (L/999+)	--	1.0 D + 1.0 L (Alt Spans)

Member Length : 10'
 System : Wall
 Member Type : Header
 Building Use : Commercial
 Building Code : IBC 2021
 Design Methodology : ASD

- Deflection criteria: LL (L/360) and TL (L/240).
- Allowed moment does not reflect the adjustment for the beam stability factor.
- Applicable calculations are based on NDS.

Supports	Bearing Length			Loads to Supports (lbs)			Accessories
	Total	Available	Required	Dead	Floor Live	Factored	
1 - Trimmer - DF	1.50"	1.50"	1.50"	204	119/-14	323	None
2 - Trimmer - SPF	4.50"	4.50"	1.50"	568	320	889	None
3 - Trimmer - SPF	4.50"	4.50"	1.50"	568	320	889	None
4 - Trimmer - DF	1.50"	1.50"	1.50"	204	119/-14	323	None

Lateral Bracing	Bracing Intervals	Comments
Top Edge (Lu)	10' o/c	
Bottom Edge (Lu)	10' o/c	

•Maximum allowable bracing intervals based on applied load.

Vertical Loads	Location	Tributary Width	Dead (0.90)	Floor Live (1.00)	Comments
0 - Self Weight (PLF)	0 to 10'	N/A	6.4	--	
1 - Uniform (PSF)	0 to 10'	9'	12.0	--	4TH LEVEL WALL
2 - Uniform (PSF)	0 to 10'	2'	20.0	40.0	4TH LEVEL FLOOR

Weyerhaeuser Notes

Weyerhaeuser warrants that the sizing of its products will be in accordance with Weyerhaeuser product design criteria and published design values. Weyerhaeuser expressly disclaims any other warranties related to the software. Use of this software is not intended to circumvent the need for a design professional as determined by the authority having jurisdiction. The designer of record, builder or framer is responsible to assure that this calculation is compatible with the overall project. Accessories (Rim Board, Blocking Panels and Squash Blocks) are not designed by this software. Products manufactured at Weyerhaeuser facilities are third-party certified to sustainable forestry standards. Weyerhaeuser Engineered Lumber Products have been evaluated by ICC-ES under evaluation reports ESR-1153 and ESR-1387 and/or tested in accordance with applicable ASTM standards. For current code evaluation reports, Weyerhaeuser product literature and installation details refer to www.weyerhaeuser.com/woodproducts/document-library.

The product application, input design loads, dimensions and support information have been provided by ForteWEB Software Operator

ForteWEB Software Operator	Job Notes
Royal Mortier PLIRIS (509) 530-8713 royalm@mortierang.com	



3RD LEVEL, 14'-FRONT BALCONY BEAM
1 piece(s) 6 x 8 DF No.2

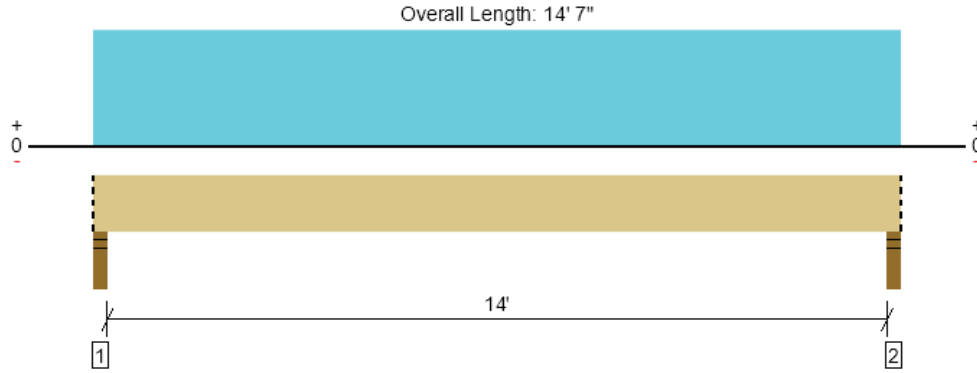

Drawing is Conceptual. All locations are measured from the outside face of left support (or left cantilever end). All dimensions are horizontal (typ.).

Design Results	Actual @ Location	Allowed	Result	LDF	Load: Combination (Pattern)
Member Reaction (lbs)	1072 @ 2"	12031 (3.50")	Passed (9%)	--	1.0 D + 1.0 S (All Spans)
Shear (lbs)	937 @ 11"	5376	Passed (17%)	1.15	1.0 D + 1.0 S (All Spans)
Moment (Ft-lbs)	3730 @ 7' 3 1/2"	3706	Passed (101%)	1.15	1.0 D + 1.0 S (All Spans)
Live Load Defl. (in)	0.208 @ 7' 3 1/2"	0.712	Passed (L/824)	--	1.0 D + 1.0 S (All Spans)
Total Load Defl. (in)	0.542 @ 7' 3 1/2"	0.950	Passed (L/315)	--	1.0 D + 1.0 S (All Spans)

Member Length : 14' 7"
 System : Roof
 Member Type : Drop Beam
 Building Use : Commercial
 Building Code : IBC 2021
 Design Methodology : ASD
 Member Pitch : 0/12

- Deflection criteria: LL (L/240) and TL (L/180).
- Allowed moment does not reflect the adjustment for the beam stability factor.
- Applicable calculations are based on NDS.

Supports	Bearing Length			Loads to Supports (lbs)				Accessories
	Total	Available	Required	Dead	Roof Live	Snow	Factored	
1 - Stud wall - DF	3.50"	3.50"	1.50"	661	328	410	1072	Blocking
2 - Stud wall - DF	3.50"	3.50"	1.50"	661	328	410	1072	Blocking

• Blocking Panels are assumed to carry no loads applied directly above them and the full load is applied to the member being designed.

Lateral Bracing	Bracing Intervals	Comments
Top Edge (Lu)	6" o/c	
Bottom Edge (Lu)	14' 7" o/c	

•Maximum allowable bracing intervals based on applied load.

Vertical Loads	Location (Side)	Tributary Width	Dead (0.90)	Roof Live (1.25)	Snow (1.15)	Comments
0 - Self Weight (PLF)	0 to 14' 7"	N/A	10.4	--	--	
1 - Uniform (PSF)	0 to 14' 7" (Front)	2' 3"	25.0	20.0	25.0	ROOF
2 - Uniform (PSF)	0 to 14' 7" (Front)	2'	12.0	--	--	PARAPET

• Side loads are assumed to not induce cross-grain tension.

Weyerhaeuser Notes

Weyerhaeuser warrants that the sizing of its products will be in accordance with Weyerhaeuser product design criteria and published design values. Weyerhaeuser expressly disclaims any other warranties related to the software. Use of this software is not intended to circumvent the need for a design professional as determined by the authority having jurisdiction. The designer of record, builder or framer is responsible to assure that this calculation is compatible with the overall project. Accessories (Rim Board, Blocking Panels and Squash Blocks) are not designed by this software. Products manufactured at Weyerhaeuser facilities are third-party certified to sustainable forestry standards. Weyerhaeuser Engineered Lumber Products have been evaluated by ICC-ES under evaluation reports ESR-1153 and ESR-1387 and/or tested in accordance with applicable ASTM standards. For current code evaluation reports, Weyerhaeuser product literature and installation details refer to www.weyerhaeuser.com/woodproducts/document-library.

The product application, input design loads, dimensions and support information have been provided by ForteWEB Software Operator

ForteWEB Software Operator	Job Notes
Royal Mortier PLIRIS (509) 530-8713 royalm@mortierang.com	



3RD LEVEL, 3'-INTERIOR HEADER
2 piece(s) 2 x 6 DF No.2

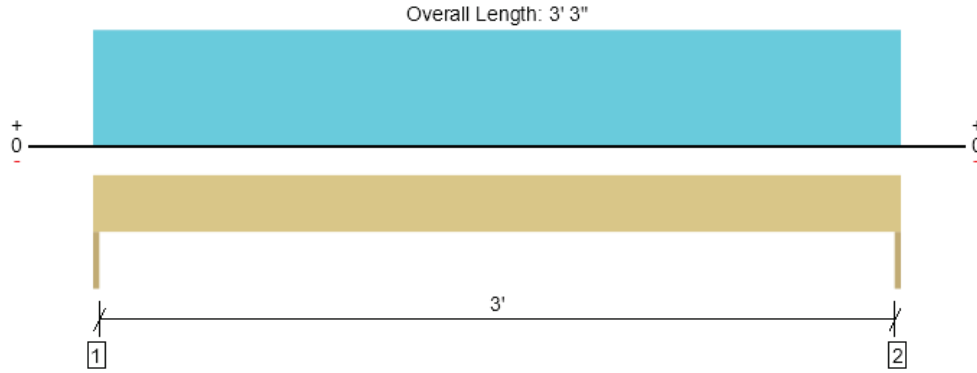

Drawing is Conceptual. All locations are measured from the outside face of left support (or left cantilever end). All dimensions are horizontal (typ.).

Design Results	Actual @ Location	Allowed	Result	LDF	Load: Combination (Pattern)
Member Reaction (lbs)	811 @ 0	2813 (1.50")	Passed (29%)	--	1.0 D + 1.0 L (All Spans)
Shear (lbs)	520 @ 7"	1980	Passed (26%)	1.00	1.0 D + 1.0 L (All Spans)
Moment (Ft-lbs)	659 @ 1' 7 1/2"	1475	Passed (45%)	1.00	1.0 D + 1.0 L (All Spans)
Live Load Defl. (in)	0.012 @ 1' 7 1/2"	0.108	Passed (L/999+)	--	1.0 D + 1.0 L (All Spans)
Total Load Defl. (in)	0.019 @ 1' 7 1/2"	0.162	Passed (L/999+)	--	1.0 D + 1.0 L (All Spans)

Member Length : 3' 3"
System : Wall
Member Type : Header
Building Use : Commercial
Building Code : IBC 2021
Design Methodology : ASD

- Deflection criteria: LL (L/360) and TL (L/240).
- Allowed moment does not reflect the adjustment for the beam stability factor.
- Applicable calculations are based on NDS.

Supports	Bearing Length			Loads to Supports (lbs)			Accessories
	Total	Available	Required	Dead	Floor Live	Factored	
1 - Trimmer - DF	1.50"	1.50"	1.50"	275	536	811	None
2 - Trimmer - DF	1.50"	1.50"	1.50"	275	536	811	None

Lateral Bracing	Bracing Intervals	Comments
Top Edge (Lu)	3' 3" o/c	
Bottom Edge (Lu)	3' 3" o/c	

•Maximum allowable bracing intervals based on applied load.

Vertical Loads	Location	Tributary Width	Dead (0.90)	Floor Live (1.00)	Comments
0 - Self Weight (PLF)	0 to 3' 3"	N/A	4.2	--	
1 - Uniform (PSF)	0 to 3' 3"	8' 3"	20.0	40.0	4TH LEVEL FLOOR

Weyerhaeuser Notes

Weyerhaeuser warrants that the sizing of its products will be in accordance with Weyerhaeuser product design criteria and published design values. Weyerhaeuser expressly disclaims any other warranties related to the software. Use of this software is not intended to circumvent the need for a design professional as determined by the authority having jurisdiction. The designer of record, builder or framer is responsible to assure that this calculation is compatible with the overall project. Accessories (Rim Board, Blocking Panels and Squash Blocks) are not designed by this software. Products manufactured at Weyerhaeuser facilities are third-party certified to sustainable forestry standards. Weyerhaeuser Engineered Lumber Products have been evaluated by ICC-ES under evaluation reports ESR-1153 and ESR-1387 and/or tested in accordance with applicable ASTM standards. For current code evaluation reports, Weyerhaeuser product literature and installation details refer to www.weyerhaeuser.com/woodproducts/document-library.

The product application, input design loads, dimensions and support information have been provided by ForteWEB Software Operator

ForteWEB Software Operator	Job Notes
Royal Mortier PLIRIS (509) 530-8713 royalm@mortierang.com	



3RD LEVEL, 5'-INTERIOR HEADER

1 piece(s) 4 x 8 DF No.2

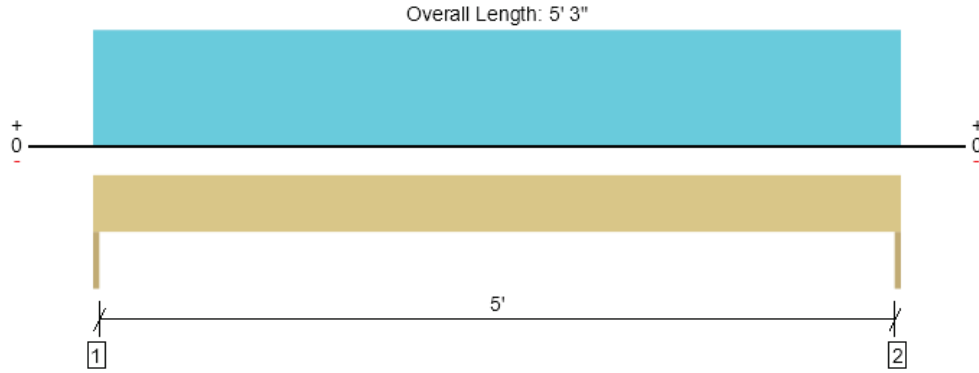

Drawing is Conceptual. All locations are measured from the outside face of left support (or left cantilever end). All dimensions are horizontal (typ.).

Design Results	Actual @ Location	Allowed	Result	LDF	Load: Combination (Pattern)
Member Reaction (lbs)	1316 @ 0	3281 (1.50")	Passed (40%)	--	1.0 D + 1.0 L (All Spans)
Shear (lbs)	951 @ 8 3/4"	3045	Passed (31%)	1.00	1.0 D + 1.0 L (All Spans)
Moment (Ft-lbs)	1728 @ 2' 7 1/2"	2989	Passed (58%)	1.00	1.0 D + 1.0 L (All Spans)
Live Load Defl. (in)	0.032 @ 2' 7 1/2"	0.175	Passed (L/999+)	--	1.0 D + 1.0 L (All Spans)
Total Load Defl. (in)	0.048 @ 2' 7 1/2"	0.262	Passed (L/999+)	--	1.0 D + 1.0 L (All Spans)

Member Length : 5' 3"
 System : Wall
 Member Type : Header
 Building Use : Commercial
 Building Code : IBC 2021
 Design Methodology : ASD

- Deflection criteria: LL (L/360) and TL (L/240).
- Allowed moment does not reflect the adjustment for the beam stability factor.
- Applicable calculations are based on NDS.

Supports	Bearing Length			Loads to Supports (lbs)			Accessories
	Total	Available	Required	Dead	Floor Live	Factored	
1 - Trimmer - DF	1.50"	1.50"	1.50"	450	866	1316	None
2 - Trimmer - DF	1.50"	1.50"	1.50"	450	866	1316	None

Lateral Bracing	Bracing Intervals	Comments
Top Edge (Lu)	5' 3" o/c	
Bottom Edge (Lu)	5' 3" o/c	

•Maximum allowable bracing intervals based on applied load.

Vertical Loads	Location	Tributary Width	Dead (0.90)	Floor Live (1.00)	Comments
0 - Self Weight (PLF)	0 to 5' 3"	N/A	6.4	--	
1 - Uniform (PSF)	0 to 5' 3"	8' 3"	20.0	40.0	4TH LEVEL FLOOR

Weyerhaeuser Notes

Weyerhaeuser warrants that the sizing of its products will be in accordance with Weyerhaeuser product design criteria and published design values. Weyerhaeuser expressly disclaims any other warranties related to the software. Use of this software is not intended to circumvent the need for a design professional as determined by the authority having jurisdiction. The designer of record, builder or framer is responsible to assure that this calculation is compatible with the overall project. Accessories (Rim Board, Blocking Panels and Squash Blocks) are not designed by this software. Products manufactured at Weyerhaeuser facilities are third-party certified to sustainable forestry standards. Weyerhaeuser Engineered Lumber Products have been evaluated by ICC-ES under evaluation reports ESR-1153 and ESR-1387 and/or tested in accordance with applicable ASTM standards. For current code evaluation reports, Weyerhaeuser product literature and installation details refer to www.weyerhaeuser.com/woodproducts/document-library.

The product application, input design loads, dimensions and support information have been provided by ForteWEB Software Operator

ForteWEB Software Operator	Job Notes
Royal Mortier PLIRIS (509) 530-8713 royalm@mortierang.com	



3RD LEVEL, 3'-FRONT WINDOW (BALCONY)

1 piece(s) 4 x 8 DF No.2

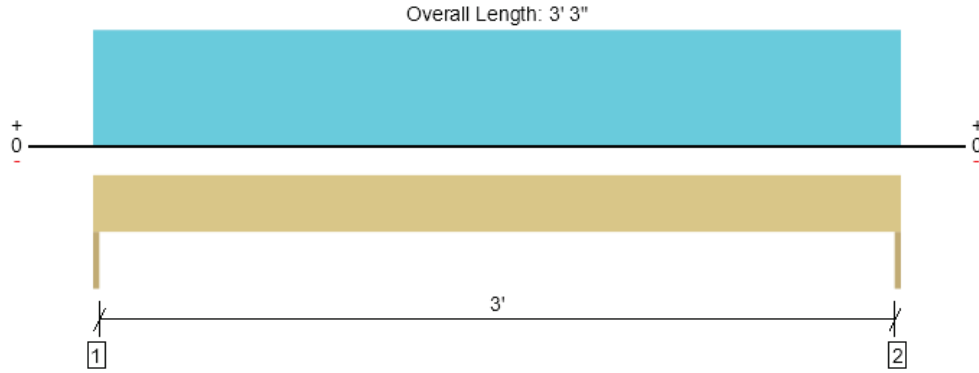

Drawing is Conceptual. All locations are measured from the outside face of left support (or left cantilever end). All dimensions are horizontal (typ.).

Design Results	Actual @ Location	Allowed	Result	LDF	Load: Combination (Pattern)
Member Reaction (lbs)	1331 @ 0	3281 (1.50")	Passed (41%)	--	1.0 D + 1.0 S (All Spans)
Shear (lbs)	734 @ 8 3/4"	3502	Passed (21%)	1.15	1.0 D + 1.0 S (All Spans)
Moment (Ft-lbs)	1081 @ 1' 7 1/2"	3438	Passed (31%)	1.15	1.0 D + 1.0 S (All Spans)
Live Load Defl. (in)	0.006 @ 1' 7 1/2"	0.108	Passed (L/999+)	--	1.0 D + 1.0 S (All Spans)
Total Load Defl. (in)	0.012 @ 1' 7 1/2"	0.162	Passed (L/999+)	--	1.0 D + 1.0 S (All Spans)

Member Length : 3' 3"
 System : Wall
 Member Type : Header
 Building Use : Commercial
 Building Code : IBC 2021
 Design Methodology : ASD

- Deflection criteria: LL (L/360) and TL (L/240).
- Allowed moment does not reflect the adjustment for the beam stability factor.
- Applicable calculations are based on NDS.

Supports	Bearing Length			Loads to Supports (lbs)				Accessories
	Total	Available	Required	Dead	Roof Live	Snow	Factored	
1 - Trimmer - DF	1.50"	1.50"	1.50"	671	528	660	1331	None
2 - Trimmer - DF	1.50"	1.50"	1.50"	671	528	660	1331	None

Lateral Bracing	Bracing Intervals	Comments
Top Edge (Lu)	3' 3" o/c	
Bottom Edge (Lu)	3' 3" o/c	

•Maximum allowable bracing intervals based on applied load.

Vertical Loads	Location	Tributary Width	Dead (0.90)	Roof Live (1.25)	Snow (1.15)	Comments
0 - Self Weight (PLF)	0 to 3' 3"	N/A	6.4	--	--	
1 - Uniform (PSF)	0 to 3' 3"	16' 3"	25.0	20.0	25.0	ROOF

Weyerhaeuser Notes

Weyerhaeuser warrants that the sizing of its products will be in accordance with Weyerhaeuser product design criteria and published design values. Weyerhaeuser expressly disclaims any other warranties related to the software. Use of this software is not intended to circumvent the need for a design professional as determined by the authority having jurisdiction. The designer of record, builder or framer is responsible to assure that this calculation is compatible with the overall project. Accessories (Rim Board, Blocking Panels and Squash Blocks) are not designed by this software. Products manufactured at Weyerhaeuser facilities are third-party certified to sustainable forestry standards. Weyerhaeuser Engineered Lumber Products have been evaluated by ICC-ES under evaluation reports ESR-1153 and ESR-1387 and/or tested in accordance with applicable ASTM standards. For current code evaluation reports, Weyerhaeuser product literature and installation details refer to www.weyerhaeuser.com/woodproducts/document-library.

The product application, input design loads, dimensions and support information have been provided by ForteWEB Software Operator

ForteWEB Software Operator	Job Notes
Royal Mortier PLIRIS (509) 530-8713 royalm@mortierang.com	



3RD LEVEL FLOOR FRAMING, SIDE BALCONY FLOOR JOIST
1 piece(s) 2 x 10 DF No.2 @ 16" OC

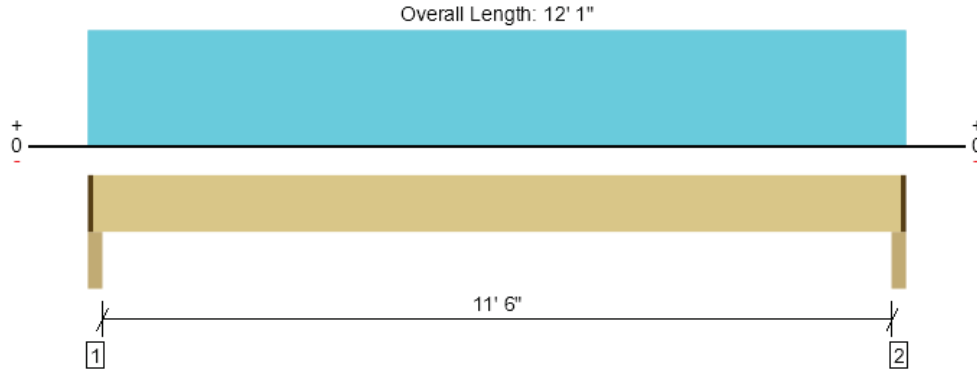

Drawing is Conceptual. All locations are measured from the outside face of left support (or left cantilever end). All dimensions are horizontal (typ.).

Design Results	Actual @ Location	Allowed	Result	LDF	Load: Combination (Pattern)
Member Reaction (lbs)	584 @ 2 1/2"	2109 (2.25")	Passed (28%)	--	1.0 D + 0.75 L + 0.75 S (All Spans)
Shear (lbs)	465 @ 1' 3/4"	1665	Passed (28%)	1.00	1.0 D + 1.0 L (All Spans)
Moment (Ft-lbs)	1588 @ 6' 1/2"	2029	Passed (78%)	1.00	1.0 D + 1.0 L (All Spans)
Live Load Defl. (in)	0.224 @ 6' 1/2"	0.292	Passed (L/625)	--	1.0 D + 0.75 L + 0.75 S (All Spans)
Total Load Defl. (in)	0.259 @ 6' 1/2"	0.583	Passed (L/541)	--	1.0 D + 0.75 L + 0.75 S (All Spans)
TJ-Pro™ Rating	N/A	N/A	N/A	--	N/A

Member Length : 11' 10 1/2"
 System : Floor
 Member Type : Joist
 Building Use : Commercial
 Building Code : IBC 2021
 Design Methodology : ASD

- Deflection criteria: LL (L/480) and TL (L/240).
- Allowed moment does not reflect the adjustment for the beam stability factor.
- A 15% increase in the moment capacity has been added to account for repetitive member usage.
- Applicable calculations are based on NDS.
- No composite action between deck and joist was considered in analysis.

Supports	Bearing Length			Loads to Supports (lbs)				Accessories
	Total	Available	Required	Dead	Floor Live	Snow	Factored	
1 - Beam - DF	3.50"	2.25"	1.50"	81	483	201	594	1 1/4" Rim Board
2 - Beam - DF	3.50"	2.25"	1.50"	81	483	201	594	1 1/4" Rim Board

• Rim Board is assumed to carry all loads applied directly above it, bypassing the member being designed.

Lateral Bracing	Bracing Intervals	Comments
Top Edge (Lu)	6' 9" o/c	
Bottom Edge (Lu)	11' 11" o/c	

•Maximum allowable bracing intervals based on applied load.

Vertical Load	Location (Side)	Spacing	Dead (0.90)	Floor Live (1.00)	Snow (1.15)	Comments
1 - Uniform (PSF)	0 to 12' 1"	16"	10.0	60.0	25.0	BALCONY

Weyerhaeuser Notes

Weyerhaeuser warrants that the sizing of its products will be in accordance with Weyerhaeuser product design criteria and published design values. Weyerhaeuser expressly disclaims any other warranties related to the software. Use of this software is not intended to circumvent the need for a design professional as determined by the authority having jurisdiction. The designer of record, builder or framer is responsible to assure that this calculation is compatible with the overall project. Accessories (Rim Board, Blocking Panels and Squash Blocks) are not designed by this software. Products manufactured at Weyerhaeuser facilities are third-party certified to sustainable forestry standards. Weyerhaeuser Engineered Lumber Products have been evaluated by ICC-ES under evaluation reports ESR-1153 and ESR-1387 and/or tested in accordance with applicable ASTM standards. For current code evaluation reports, Weyerhaeuser product literature and installation details refer to www.weyerhaeuser.com/woodproducts/document-library.

The product application, input design loads, dimensions and support information have been provided by ForteWEB Software Operator

ForteWEB Software Operator	Job Notes
Royal Mortier PLIRIS (509) 530-8713 royalm@mortierang.com	



3RD LEVEL FLOOR FRAMING, 18.5'-CANT. FLOOR BEAM
1 piece(s) 5 1/2" x 11 7/8" 24F-V4 DF Glulam

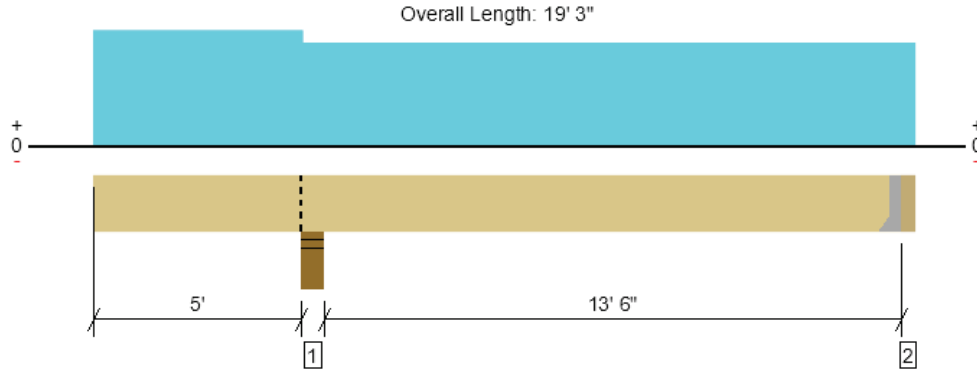

Drawing is Conceptual. All locations are measured from the outside face of left support (or left cantilever end). All dimensions are horizontal (typ.).

Design Results	Actual @ Location	Allowed	Result	LDF	Load: Combination (Pattern)
Member Reaction (lbs)	3534 @ 18' 11 1/2"	5363 (1.50")	Passed (66%)	--	1.0 D + 1.0 L (Alt Spans)
Shear (lbs)	3403 @ 6' 5 3/8"	11539	Passed (29%)	1.00	1.0 D + 1.0 L (All Spans)
Pos Moment (Ft-lbs)	11876 @ 12' 2 7/8"	25853	Passed (46%)	1.00	1.0 D + 1.0 L (Alt Spans)
Neg Moment (Ft-lbs)	-5962 @ 5' 2 3/4"	19928	Passed (30%)	1.00	1.0 D + 1.0 L (All Spans)
Live Load Defl. (in)	0.201 @ 0	0.349	Passed (2L/624)	--	1.0 D + 0.75 L + 0.75 S (Alt Spans)
Total Load Defl. (in)	0.289 @ 12' 1 3/4"	0.686	Passed (L/570)	--	1.0 D + 1.0 L (Alt Spans)

Member Length : 18' 11 1/2"
 System : Floor
 Member Type : Flush Beam
 Building Use : Commercial
 Building Code : IBC 2021
 Design Methodology : ASD

- Deflection criteria: LL (L/360) and TL (L/240).
- Overhang deflection criteria: LL (2L/360) and TL (2L/240).
- Allowed moment does not reflect the adjustment for the beam stability factor.
- Volume factor of 1.00 was calculated for positive bending using length L = 13' 5 5/16".
- Volume factor of 1.00 was calculated for negative bending using length L = 6' 10 9/16".
- The effects of positive or negative camber have not been accounted for when calculating deflection.
- The specified glulam is assumed to have its strong laminations at the bottom of the beam. Install with proper side up as indicated by the manufacturer.
- Applicable calculations are based on NDS.

Supports	Bearing Length			Loads to Supports (lbs)				Accessories
	Total	Available	Required	Dead	Floor Live	Snow	Factored	
1 - Stud wall - DF	5.50"	5.50"	1.85"	1774	4570	899	6344	Blocking
2 - Hanger on 11 7/8" DF beam	3.50"	Hanger ¹	1.50"	1250	2433/-259	-149	3683	See note ¹

- Blocking Panels are assumed to carry no loads applied directly above them and the full load is applied to the member being designed.
- At hanger supports, the Total Bearing dimension is equal to the width of the material that is supporting the hanger
- ¹ See Connector grid below for additional information and/or requirements.

Lateral Bracing	Bracing Intervals	Comments
Top Edge (Lu)	19' o/c	
Bottom Edge (Lu)	19' o/c	

•Maximum allowable bracing intervals based on applied load.

Connector: Simpson Strong-Tie						
Support	Model	Seat Length	Top Fasteners	Face Fasteners	Member Fasteners	Accessories
2 - Face Mount Hanger	HU614	2.50"	N/A	24-16d	12-16d	

• Refer to manufacturer notes and instructions for proper installation and use of all connectors.

Vertical Loads	Location (Side)	Tributary Width	Dead (0.90)	Floor Live (1.00)	Snow (1.15)	Comments
0 - Self Weight (PLF)	0 to 18' 11 1/2"	N/A	15.9	--	--	
1 - Uniform (PSF)	0 to 5' (Front)	6'	10.0	60.0	25.0	BALCONY
2 - Uniform (PSF)	5' to 19' 3" (Front)	8' 6"	20.0	40.0	--	FLOOR

• Side loads are assumed to not induce cross-grain tension.

FortewEB Software Operator	Job Notes
Royal Mortier PLIRIS (509) 530-8713 royalm@mortierang.com	



Weyerhaeuser Notes

Weyerhaeuser warrants that the sizing of its products will be in accordance with Weyerhaeuser product design criteria and published design values. Weyerhaeuser expressly disclaims any other warranties related to the software. Use of this software is not intended to circumvent the need for a design professional as determined by the authority having jurisdiction. The designer of record, builder or framer is responsible to assure that this calculation is compatible with the overall project. Accessories (Rim Board, Blocking Panels and Squash Blocks) are not designed by this software. Products manufactured at Weyerhaeuser facilities are third-party certified to sustainable forestry standards. Weyerhaeuser Engineered Lumber Products have been evaluated by ICC-ES under evaluation reports ESR-1153 and ESR-1387 and/or tested in accordance with applicable ASTM standards. For current code evaluation reports, Weyerhaeuser product literature and installation details refer to www.weyerhaeuser.com/woodproducts/document-library.

The product application, input design loads, dimensions and support information have been provided by ForteWEB Software Operator

ForteWEB Software Operator	Job Notes
Royal Mortier PLIRIS (509) 530-8713 royalm@mortierang.com	



3RD LEVEL FLOOR FRAMING, 15.5'-FLOOR BEAM
1 piece(s) 5 1/2" x 11 7/8" 24F-V4 DF Glulam

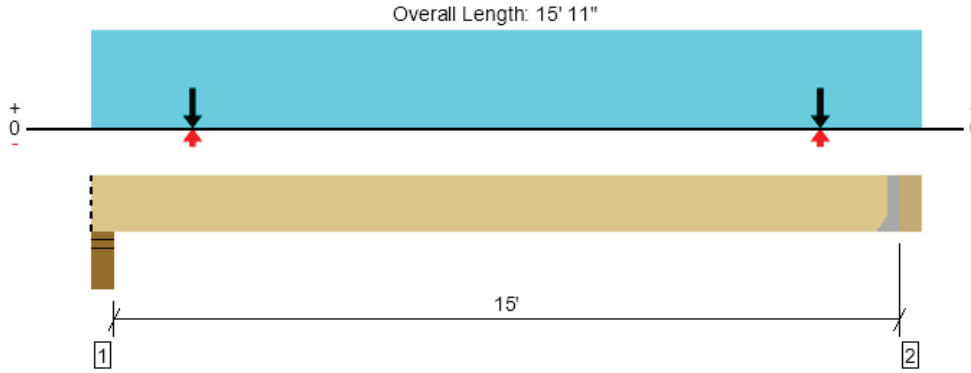

Drawing is Conceptual. All locations are measured from the outside face of left support (or left cantilever end). All dimensions are horizontal (typ.).

Design Results	Actual @ Location	Allowed	Result	LDF	Load: Combination (Pattern)
Member Reaction (lbs)	4768 @ 15' 5 1/2"	5363 (1.50")	Passed (89%)	--	1.0 D + 1.0 L (All Spans)
Shear (lbs)	4634 @ 14' 5 5/8"	11539	Passed (40%)	1.00	1.0 D + 1.0 L (All Spans)
Pos Moment (Ft-lbs)	9661 @ 7' 6 1/4"	25853	Passed (37%)	1.00	1.0 D + 1.0 L (All Spans)
Live Load Defl. (in)	0.203 @ 7' 10 1/4"	0.504	Passed (L/896)	--	1.0 D + 1.0 L (All Spans)
Total Load Defl. (in)	0.319 @ 7' 10 1/4"	0.756	Passed (L/569)	--	1.0 D + 1.0 L (All Spans)

Member Length : 15' 5 1/2"
 System : Floor
 Member Type : Flush Beam
 Building Use : Commercial
 Building Code : IBC 2021
 Design Methodology : ASD

- Deflection criteria: LL (L/360) and TL (L/240).
- Allowed moment does not reflect the adjustment for the beam stability factor.
- Volume factor of 1.00 was calculated for positive bending using length L = 15' 1 1/2".
- The effects of positive or negative camber have not been accounted for when calculating deflection.
- The specified glulam is assumed to have its strong laminations at the bottom of the beam. Install with proper side up as indicated by the manufacturer.
- Applicable calculations are based on NDS.

Supports	Bearing Length			Loads to Supports (lbs)				Accessories
	Total	Available	Required	Dead	Floor Live	Snow	Factored	
1 - Stud wall - DF	5.50"	5.50"	1.50"	1674	3038	-148	4712	Blocking
2 - Hanger on 11 7/8" DF beam	5.50"	Hanger ¹	1.50"	1708	3115	-152	4823	See note ¹

- Blocking Panels are assumed to carry no loads applied directly above them and the full load is applied to the member being designed.
- At hanger supports, the Total Bearing dimension is equal to the width of the material that is supporting the hanger
- ¹ See Connector grid below for additional information and/or requirements.

Lateral Bracing	Bracing Intervals	Comments
Top Edge (Lu)	15' 6" o/c	
Bottom Edge (Lu)	15' 6" o/c	

•Maximum allowable bracing intervals based on applied load.

Connector: Simpson Strong-Tie

Support	Model	Seat Length	Top Fasteners	Face Fasteners	Member Fasteners	Accessories
2 - Face Mount Hanger	HGUS5.50/10	4.00"	N/A	46-10d	16-10d	

• Refer to manufacturer notes and instructions for proper installation and use of all connectors.

Vertical Loads	Location (Side)	Tributary Width	Dead (0.90)	Floor Live (1.00)	Snow (1.15)	Comments
0 - Self Weight (PLF)	0 to 15' 5 1/2"	N/A	15.9	--	--	
1 - Point (lb)	2' (Back)	N/A	1250	2440	-150	18.5'-CANT. FLOOR BEAM
2 - Point (lb)	14' (Back)	N/A	1250	2440	-150	18.5'-CANT. FLOOR BEAM
3 - Uniform (PSF)	0 to 15' 11" (Front)	2'	20.0	40.0	--	FLOOR

• Side loads are assumed to not induce cross-grain tension.

Forteweb Software Operator	Job Notes
Royal Mortier PLIRIS (509) 530-8713 royalm@mortierang.com	



Weyerhaeuser Notes

Weyerhaeuser warrants that the sizing of its products will be in accordance with Weyerhaeuser product design criteria and published design values. Weyerhaeuser expressly disclaims any other warranties related to the software. Use of this software is not intended to circumvent the need for a design professional as determined by the authority having jurisdiction. The designer of record, builder or framer is responsible to assure that this calculation is compatible with the overall project. Accessories (Rim Board, Blocking Panels and Squash Blocks) are not designed by this software. Products manufactured at Weyerhaeuser facilities are third-party certified to sustainable forestry standards. Weyerhaeuser Engineered Lumber Products have been evaluated by ICC-ES under evaluation reports ESR-1153 and ESR-1387 and/or tested in accordance with applicable ASTM standards. For current code evaluation reports, Weyerhaeuser product literature and installation details refer to www.weyerhaeuser.com/woodproducts/document-library.

The product application, input design loads, dimensions and support information have been provided by ForteWEB Software Operator

ForteWEB Software Operator	Job Notes
Royal Mortier PLIRIS (509) 530-8713 royalm@mortierang.com	



3RD LEVEL FLOOR FRAMING, 38.25'-FLOOR BEAM (MULTI-SPAN)

1 piece(s) 5 1/2" x 19 1/2" 24F-V4 DF Glulam

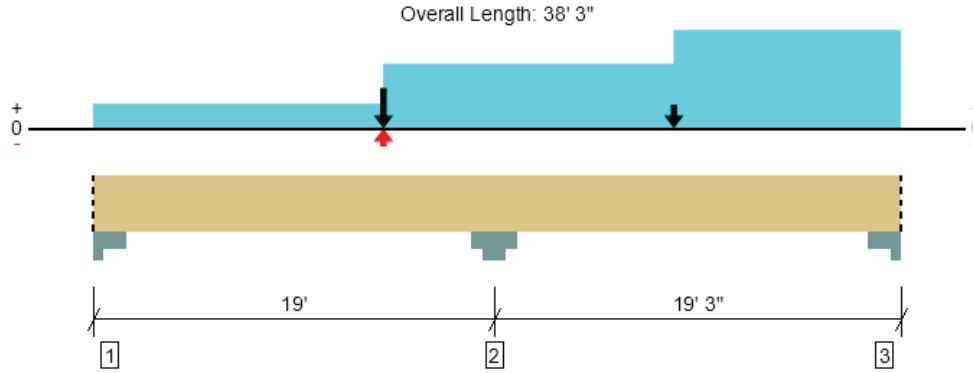

Drawing is Conceptual. All locations are measured from the outside face of left support (or left cantilever end). All dimensions are horizontal (typ.).

Design Results	Actual @ Location	Allowed	Result	LDF	Load: Combination (Pattern)
Member Reaction (lbs)	28844 @ 19'	39325 (11.00")	Passed (73%)	--	1.0 D + 1.0 L (All Spans)
Shear (lbs)	14576 @ 16' 11"	18948	Passed (77%)	1.00	1.0 D + 1.0 L (All Spans)
Pos Moment (Ft-lbs)	37927 @ 29' 5 15/16"	68158	Passed (56%)	1.00	1.0 D + 1.0 L (Alt Spans)
Neg Moment (Ft-lbs)	-53973 @ 19'	53737	Passed (100%)	1.00	1.0 D + 1.0 L (All Spans)
Live Load Defl. (in)	0.232 @ 28' 10 13/16"	0.624	Passed (L/969)	--	1.0 D + 1.0 L (Alt Spans)
Total Load Defl. (in)	0.327 @ 29' 2 1/2"	0.935	Passed (L/687)	--	1.0 D + 1.0 L (Alt Spans)

Member Length : 38' 3"
 System : Floor
 Member Type : Flush Beam
 Building Use : Commercial
 Building Code : IBC 2021
 Design Methodology : ASD

- Deflection criteria: LL (L/360) and TL (L/240).
- Allowed moment does not reflect the adjustment for the beam stability factor.
- Volume factor of 0.98 was calculated for positive bending using length L = 15' 1 1/16".
- Volume factor of 1.00 was calculated for negative bending using length L = 8' 7 9/16".
- The effects of positive or negative camber have not been accounted for when calculating deflection.
- The specified glulam is assumed to have its strong laminations at the bottom of the beam. Install with proper side up as indicated by the manufacturer.
- Applicable calculations are based on NDS.

Supports	Bearing Length			Loads to Supports (lbs)				Accessories
	Total	Available	Required	Dead	Floor Live	Snow	Factored	
1 - Column Cap - steel	8.00"	8.00"	1.50"	1930	2591/-838	-61	4521	Blocking
2 - Column Cap - steel	11.00"	11.00"	8.07"	12032	16811	-275	28844	None
3 - Column Cap - steel	8.00"	8.00"	2.75"	3703	6140/-854	27	9843	Blocking

• Blocking Panels are assumed to carry no loads applied directly above them and the full load is applied to the member being designed.

Lateral Bracing	Bracing Intervals	Comments
Top Edge (Lu)	38' 3" o/c	
Bottom Edge (Lu)	6" o/c	

•Maximum allowable bracing intervals based on applied load.

Vertical Loads	Location (Side)	Tributary Width	Dead (0.90)	Floor Live (1.00)	Snow (1.15)	Comments
0 - Self Weight (PLF)	0 to 38' 3"	N/A	26.1	--	--	
1 - Uniform (PSF)	0 to 13' 9" (Top)	1' 3"	20.0	40.0	--	4TH LEVEL FLOOR
2 - Point (lb)	13' 9" (Top)	N/A	2480	4470	-155	15.5'-FLOOR BEAM (4TH LEVEL)
3 - Uniform (PSF)	13' 9" to 27' 6" (Top)	2'	20.0	40.0	--	STAIRS
4 - Point (lb)	27' 6" (Top)	N/A	1225	2020	--	15.5'-FLOOR BEAM (4TH LEVEL)
5 - Uniform (PSF)	27' 6" to 38' 3" (Top)	8' 3"	20.0	40.0	--	4TH LEVEL FLOOR
6 - Uniform (PSF)	0 to 38' 3" (Top)	9'	12.0	--	--	3RD LEVEL WALL
7 - Uniform (PSF)	0 to 13' 9" (Front)	1' 6"	20.0	40.0	--	3RD LEVEL FLOOR
8 - Point (lb)	13' 9" (Front)	N/A	1710	3115	-155	15.5'-FLOOR BEAM (3RD LEVEL)
9 - Uniform (PSF)	13' 9" to 38' 3" (Front)	8' 3"	20.0	40.0	--	3RD LEVEL FLOOR

• Side loads are assumed to not induce cross-grain tension.

FortewEB Software Operator	Job Notes
Royal Mortier PLIRIS (509) 530-8713 royalm@mortierang.com	



Weyerhaeuser Notes

Weyerhaeuser warrants that the sizing of its products will be in accordance with Weyerhaeuser product design criteria and published design values. Weyerhaeuser expressly disclaims any other warranties related to the software. Use of this software is not intended to circumvent the need for a design professional as determined by the authority having jurisdiction. The designer of record, builder or framer is responsible to assure that this calculation is compatible with the overall project. Accessories (Rim Board, Blocking Panels and Squash Blocks) are not designed by this software. Products manufactured at Weyerhaeuser facilities are third-party certified to sustainable forestry standards. Weyerhaeuser Engineered Lumber Products have been evaluated by ICC-ES under evaluation reports ESR-1153 and ESR-1387 and/or tested in accordance with applicable ASTM standards. For current code evaluation reports, Weyerhaeuser product literature and installation details refer to www.weyerhaeuser.com/woodproducts/document-library.

The product application, input design loads, dimensions and support information have been provided by ForteWEB Software Operator

ForteWEB Software Operator	Job Notes
Royal Mortier PLIRIS (509) 530-8713 royalm@mortierang.com	



3RD LEVEL FLOOR FRAMING, FRONT BALCONY JOIST
1 piece(s) 2 x 10 DF No.2 @ 16" OC

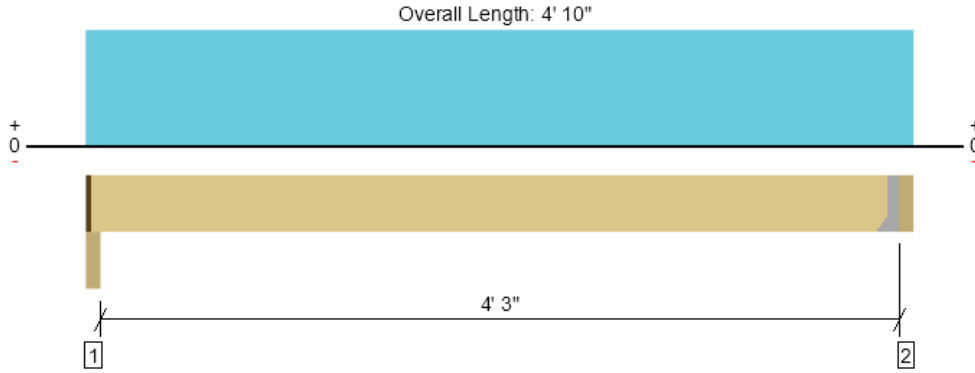

Drawing is Conceptual. All locations are measured from the outside face of left support (or left cantilever end). All dimensions are horizontal (typ.).

Design Results	Actual @ Location	Allowed	Result	LDF	Load: Combination (Pattern)
Member Reaction (lbs)	213 @ 4' 6 1/2"	1406 (1.50")	Passed (15%)	--	1.0 D + 0.75 L + 0.75 S (All Spans)
Shear (lbs)	130 @ 3' 9 1/4"	1665	Passed (8%)	1.00	1.0 D + 1.0 L (All Spans)
Moment (Ft-lbs)	219 @ 2' 4 1/2"	2029	Passed (11%)	1.00	1.0 D + 1.0 L (All Spans)
Live Load Defl. (in)	0.004 @ 2' 4 1/2"	0.108	Passed (L/999+)	--	1.0 D + 0.75 L + 0.75 S (All Spans)
Total Load Defl. (in)	0.005 @ 2' 4 1/2"	0.217	Passed (L/999+)	--	1.0 D + 0.75 L + 0.75 S (All Spans)
TJ-Pro™ Rating	N/A	N/A	N/A	--	N/A

Member Length : 4' 5 1/4"
 System : Floor
 Member Type : Joist
 Building Use : Commercial
 Building Code : IBC 2021
 Design Methodology : ASD

- Deflection criteria: LL (L/480) and TL (L/240).
- Allowed moment does not reflect the adjustment for the beam stability factor.
- A 15% increase in the moment capacity has been added to account for repetitive member usage.
- Applicable calculations are based on NDS.
- No composite action between deck and joist was considered in analysis.

Supports	Bearing Length			Loads to Supports (lbs)				Accessories
	Total	Available	Required	Dead	Floor Live	Snow	Factored	
1 - Beam - DF	3.50"	2.25"	1.50"	32	190	79	234	1 1/4" Rim Board
2 - Hanger on 9 1/4" DF Ledger	3.50"	Hanger ¹	1.50"	33	197	82	242	See note ¹

- Rim Board is assumed to carry all loads applied directly above it, bypassing the member being designed.
- At hanger supports, the Total Bearing dimension is equal to the width of the material that is supporting the hanger
- ¹ See Connector grid below for additional information and/or requirements.

Lateral Bracing	Bracing Intervals	Comments
Top Edge (Lu)	4' 5" o/c	
Bottom Edge (Lu)	4' 5" o/c	

•Maximum allowable bracing intervals based on applied load.

Connector: Simpson Strong-Tie						
Support	Model	Seat Length	Top Fasteners	Face Fasteners	Member Fasteners	Accessories
2 - Face Mount Hanger	LU28	1.50"	N/A	8-10dx1.5	6-10dx1.5	

- Refer to manufacturer notes and instructions for proper installation and use of all connectors.

Vertical Load	Location (Side)	Spacing	Dead (0.90)	Floor Live (1.00)	Snow (1.15)	Comments
1 - Uniform (PSF)	0 to 4' 10"	16"	10.0	60.0	25.0	BALCONY

Weyerhaeuser Notes

Weyerhaeuser warrants that the sizing of its products will be in accordance with Weyerhaeuser product design criteria and published design values. Weyerhaeuser expressly disclaims any other warranties related to the software. Use of this software is not intended to circumvent the need for a design professional as determined by the authority having jurisdiction. The designer of record, builder or framer is responsible to assure that this calculation is compatible with the overall project. Accessories (Rim Board, Blocking Panels and Squash Blocks) are not designed by this software. Products manufactured at Weyerhaeuser facilities are third-party certified to sustainable forestry standards. Weyerhaeuser Engineered Lumber Products have been evaluated by ICC-ES under evaluation reports ESR-1153 and ESR-1387 and/or tested in accordance with applicable ASTM standards. For current code evaluation reports, Weyerhaeuser product literature and installation details refer to www.weyerhaeuser.com/woodproducts/document-library.

The product application, input design loads, dimensions and support information have been provided by ForteWEB Software Operator

ForteWEB Software Operator	Job Notes
Royal Mortier PLIRIS (509) 530-8713 royalm@mortierang.com	



3RD LEVEL FLOOR FRAMING, FRONT BALCONY BEAM
1 piece(s) 6 x 10 DF No.2

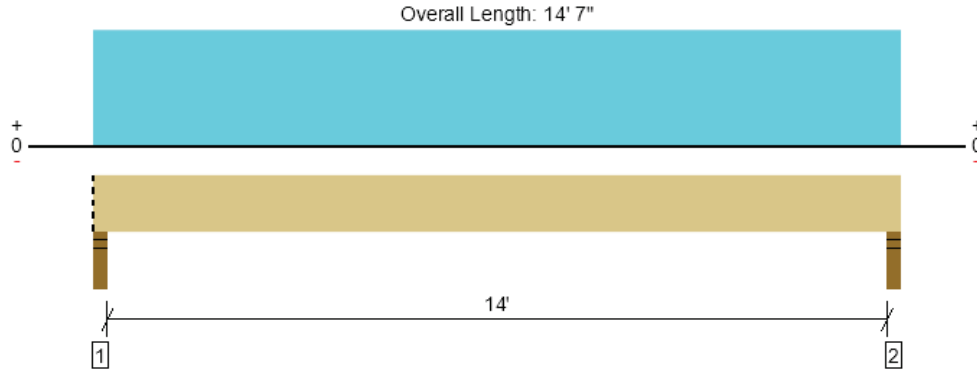

Drawing is Conceptual. All locations are measured from the outside face of left support (or left cantilever end). All dimensions are horizontal (typ.).

Design Results	Actual @ Location	Allowed	Result	LDF	Load: Combination (Pattern)
Member Reaction (lbs)	1306 @ 2"	12031 (3.50")	Passed (11%)	--	1.0 D + 0.75 L + 0.75 S (All Spans)
Shear (lbs)	1060 @ 1' 1"	5922	Passed (18%)	1.00	1.0 D + 1.0 L (All Spans)
Moment (Ft-lbs)	4334 @ 7' 3 1/2"	6032	Passed (72%)	1.00	1.0 D + 1.0 L (All Spans)
Live Load Defl. (in)	0.261 @ 7' 3 1/2"	0.475	Passed (L/656)	--	1.0 D + 0.75 L + 0.75 S (All Spans)
Total Load Defl. (in)	0.325 @ 7' 3 1/2"	0.712	Passed (L/526)	--	1.0 D + 0.75 L + 0.75 S (All Spans)

Member Length : 14' 7"
 System : Floor
 Member Type : Drop Beam
 Building Use : Commercial
 Building Code : IBC 2021
 Design Methodology : ASD

- Deflection criteria: LL (L/360) and TL (L/240).
- Allowed moment does not reflect the adjustment for the beam stability factor.
- Lumber grading provisions must be extended over the length of the member per NDS 4.2.5.5.
- Applicable calculations are based on NDS.

Supports	Bearing Length			Loads to Supports (lbs)				Accessories
	Total	Available	Required	Dead	Floor Live	Snow	Factored	
1 - Stud wall - DF	3.50"	3.50"	1.50"	261	984	410	1306	Blocking
2 - Stud wall - DF	3.50"	3.50"	1.50"	261	984	410	1306	None

• Blocking Panels are assumed to carry no loads applied directly above them and the full load is applied to the member being designed.

Lateral Bracing	Bracing Intervals	Comments
Top Edge (Lu)	14' 7" o/c	
Bottom Edge (Lu)	14' 7" o/c	

•Maximum allowable bracing intervals based on applied load.

Vertical Loads	Location (Side)	Tributary Width	Dead (0.90)	Floor Live (1.00)	Snow (1.15)	Comments
0 - Self Weight (PLF)	0 to 14' 7"	N/A	13.2	--	--	
1 - Uniform (PSF)	0 to 14' 7" (Front)	2' 3"	10.0	60.0	25.0	BALCONY

• Side loads are assumed to not induce cross-grain tension.

Weyerhaeuser Notes
 Weyerhaeuser warrants that the sizing of its products will be in accordance with Weyerhaeuser product design criteria and published design values. Weyerhaeuser expressly disclaims any other warranties related to the software. Use of this software is not intended to circumvent the need for a design professional as determined by the authority having jurisdiction. The designer of record, builder or framer is responsible to assure that this calculation is compatible with the overall project. Accessories (Rim Board, Blocking Panels and Squash Blocks) are not designed by this software. Products manufactured at Weyerhaeuser facilities are third-party certified to sustainable forestry standards. Weyerhaeuser Engineered Lumber Products have been evaluated by ICC-ES under evaluation reports ESR-1153 and ESR-1387 and/or tested in accordance with applicable ASTM standards. For current code evaluation reports, Weyerhaeuser product literature and installation details refer to www.weyerhaeuser.com/woodproducts/document-library.
 The product application, input design loads, dimensions and support information have been provided by ForteWEB Software Operator

ForteWEB Software Operator	Job Notes
Royal Mortier PLIRIS (509) 530-8713 royalm@mortierang.com	



2ND LEVEL, 2.75'-FRONT WINDOW

1 piece(s) 4 x 8 DF No.2

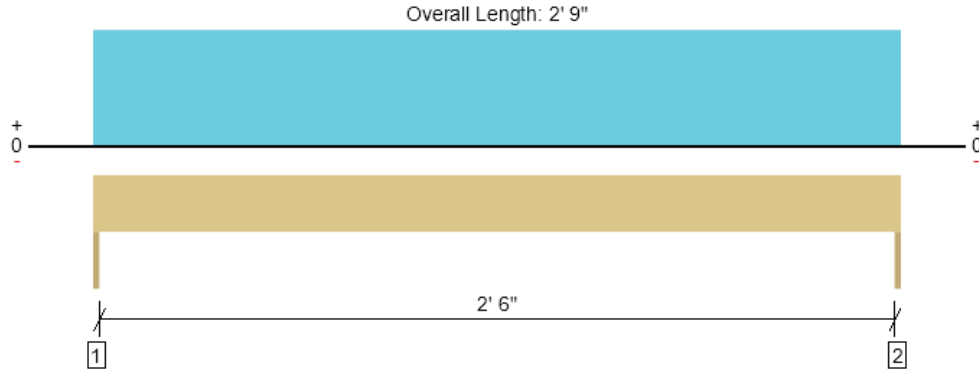

Drawing is Conceptual. All locations are measured from the outside face of left support (or left cantilever end). All dimensions are horizontal (typ.).

Design Results	Actual @ Location	Allowed	Result	LDF	Load: Combination (Pattern)
Member Reaction (lbs)	941 @ 0	3281 (1.50")	Passed (29%)	--	1.0 D + 1.0 L (All Spans)
Shear (lbs)	442 @ 8 3/4"	3045	Passed (15%)	1.00	1.0 D + 1.0 L (All Spans)
Moment (Ft-lbs)	647 @ 1' 4 1/2"	2989	Passed (22%)	1.00	1.0 D + 1.0 L (All Spans)
Live Load Defl. (in)	0.003 @ 1' 4 1/2"	0.092	Passed (L/999+)	--	1.0 D + 1.0 L (All Spans)
Total Load Defl. (in)	0.005 @ 1' 4 1/2"	0.138	Passed (L/999+)	--	1.0 D + 1.0 L (All Spans)

Member Length : 2' 9"
 System : Wall
 Member Type : Header
 Building Use : Commercial
 Building Code : IBC 2021
 Design Methodology : ASD

- Deflection criteria: LL (L/360) and TL (L/240).
- Allowed moment does not reflect the adjustment for the beam stability factor.
- Applicable calculations are based on NDS.

Supports	Bearing Length			Loads to Supports (lbs)			Accessories
	Total	Available	Required	Dead	Floor Live	Factored	
1 - Trimmer - DF	1.50"	1.50"	1.50"	419	523	941	None
2 - Trimmer - DF	1.50"	1.50"	1.50"	419	523	941	None

Lateral Bracing	Bracing Intervals	Comments
Top Edge (Lu)	2' 9" o/c	
Bottom Edge (Lu)	2' 9" o/c	

•Maximum allowable bracing intervals based on applied load.

Vertical Loads	Location	Tributary Width	Dead (0.90)	Floor Live (1.00)	Comments
0 - Self Weight (PLF)	0 to 2' 9"	N/A	6.4	--	
1 - Uniform (PSF)	0 to 2' 9"	9' 6"	20.0	40.0	3RD LEVEL FLOOR
2 - Uniform (PSF)	0 to 2' 9"	9'	12.0	--	3RD LEVEL WALL

Weyerhaeuser Notes

Weyerhaeuser warrants that the sizing of its products will be in accordance with Weyerhaeuser product design criteria and published design values. Weyerhaeuser expressly disclaims any other warranties related to the software. Use of this software is not intended to circumvent the need for a design professional as determined by the authority having jurisdiction. The designer of record, builder or framer is responsible to assure that this calculation is compatible with the overall project. Accessories (Rim Board, Blocking Panels and Squash Blocks) are not designed by this software. Products manufactured at Weyerhaeuser facilities are third-party certified to sustainable forestry standards. Weyerhaeuser Engineered Lumber Products have been evaluated by ICC-ES under evaluation reports ESR-1153 and ESR-1387 and/or tested in accordance with applicable ASTM standards. For current code evaluation reports, Weyerhaeuser product literature and installation details refer to www.weyerhaeuser.com/woodproducts/document-library.

The product application, input design loads, dimensions and support information have been provided by ForteWEB Software Operator

ForteWEB Software Operator	Job Notes
Royal Mortier PLIRIS (509) 530-8713 royalm@mortierang.com	



2ND LEVEL, 3'-FRONT BALCONY WINDOW/DOOR
1 piece(s) 4 x 8 DF No.2

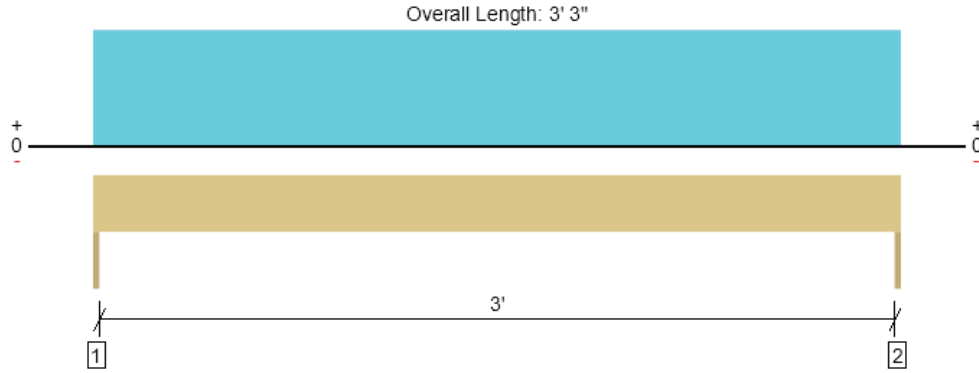

Drawing is Conceptual. All locations are measured from the outside face of left support (or left cantilever end). All dimensions are horizontal (typ.).

Design Results	Actual @ Location	Allowed	Result	LDF	Load: Combination (Pattern)
Member Reaction (lbs)	1145 @ 0	3281 (1.50")	Passed (35%)	--	1.0 D + 1.0 L (All Spans)
Shear (lbs)	631 @ 8 3/4"	3045	Passed (21%)	1.00	1.0 D + 1.0 L (All Spans)
Moment (Ft-lbs)	930 @ 1' 7 1/2"	2989	Passed (31%)	1.00	1.0 D + 1.0 L (All Spans)
Live Load Defl. (in)	0.006 @ 1' 7 1/2"	0.108	Passed (L/999+)	--	1.0 D + 1.0 L (All Spans)
Total Load Defl. (in)	0.010 @ 1' 7 1/2"	0.162	Passed (L/999+)	--	1.0 D + 1.0 L (All Spans)

Member Length : 3' 3"
 System : Wall
 Member Type : Header
 Building Use : Commercial
 Building Code : IBC 2021
 Design Methodology : ASD

- Deflection criteria: LL (L/360) and TL (L/240).
- Allowed moment does not reflect the adjustment for the beam stability factor.
- Applicable calculations are based on NDS.

Supports	Bearing Length			Loads to Supports (lbs)				Accessories
	Total	Available	Required	Dead	Floor Live	Snow	Factored	
1 - Trimmer - DF	1.50"	1.50"	1.50"	462	683	81	1145	None
2 - Trimmer - DF	1.50"	1.50"	1.50"	462	683	81	1145	None

Lateral Bracing	Bracing Intervals	Comments
Top Edge (Lu)	3' 3" o/c	
Bottom Edge (Lu)	3' 3" o/c	

•Maximum allowable bracing intervals based on applied load.

Vertical Loads	Location	Tributary Width	Dead (0.90)	Floor Live (1.00)	Snow (1.15)	Comments
0 - Self Weight (PLF)	0 to 3' 3"	N/A	6.4	--	--	
1 - Uniform (PSF)	0 to 3' 3"	7' 6"	20.0	40.0	--	3RD LEVEL FLOOR
2 - Uniform (PSF)	0 to 3' 3"	2'	10.0	60.0	25.0	3RD LEVEL BALCONY
3 - Uniform (PSF)	0 to 3' 3"	9'	12.0	--	--	3RD LEVEL WALL

Weyerhaeuser Notes

Weyerhaeuser warrants that the sizing of its products will be in accordance with Weyerhaeuser product design criteria and published design values. Weyerhaeuser expressly disclaims any other warranties related to the software. Use of this software is not intended to circumvent the need for a design professional as determined by the authority having jurisdiction. The designer of record, builder or framer is responsible to assure that this calculation is compatible with the overall project. Accessories (Rim Board, Blocking Panels and Squash Blocks) are not designed by this software. Products manufactured at Weyerhaeuser facilities are third-party certified to sustainable forestry standards. Weyerhaeuser Engineered Lumber Products have been evaluated by ICC-ES under evaluation reports ESR-1153 and ESR-1387 and/or tested in accordance with applicable ASTM standards. For current code evaluation reports, Weyerhaeuser product literature and installation details refer to www.weyerhaeuser.com/woodproducts/document-library.

The product application, input design loads, dimensions and support information have been provided by ForteWEB Software Operator

ForteWEB Software Operator	Job Notes
Royal Mortier PLIRIS (509) 530-8713 royalm@mortierang.com	



2ND LEVEL, 2.25'-REAR WINDOW

1 piece(s) 4 x 8 DF No.2

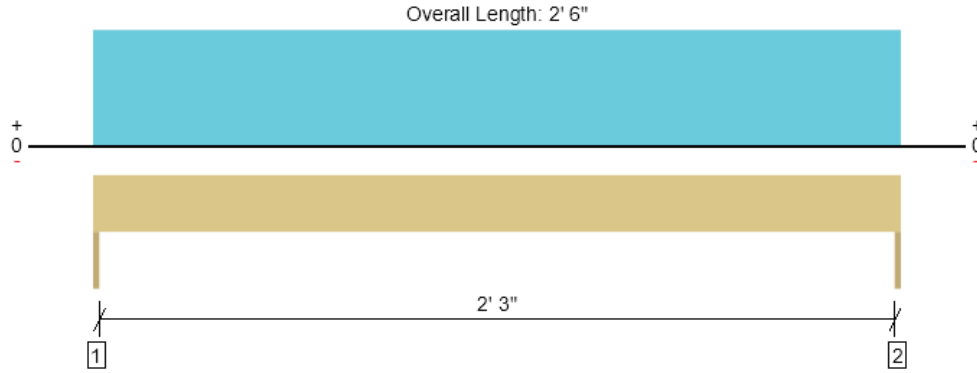

Drawing is Conceptual. All locations are measured from the outside face of left support (or left cantilever end). All dimensions are horizontal (typ.).

Design Results	Actual @ Location	Allowed	Result	LDF	Load: Combination (Pattern)
Member Reaction (lbs)	2071 @ 0	3281 (1.50")	Passed (63%)	--	1.0 D + 0.75 L + 0.75 S (All Spans)
Shear (lbs)	776 @ 8 3/4"	3045	Passed (25%)	1.00	1.0 D + 1.0 L (All Spans)
Moment (Ft-lbs)	1164 @ 1' 3"	2989	Passed (39%)	1.00	1.0 D + 1.0 L (All Spans)
Live Load Defl. (in)	0.004 @ 1' 3"	0.083	Passed (L/999+)	--	1.0 D + 0.75 L + 0.75 S (All Spans)
Total Load Defl. (in)	0.008 @ 1' 3"	0.125	Passed (L/999+)	--	1.0 D + 0.75 L + 0.75 S (All Spans)

Member Length : 2' 6"
 System : Wall
 Member Type : Header
 Building Use : Commercial
 Building Code : IBC 2021
 Design Methodology : ASD

- Deflection criteria: LL (L/360) and TL (L/240).
- Allowed moment does not reflect the adjustment for the beam stability factor.
- Applicable calculations are based on NDS.

Supports	Bearing Length			Loads to Supports (lbs)					Accessories
	Total	Available	Required	Dead	Floor Live	Roof Live	Snow	Factored	
1 - Trimmer - DF	1.50"	1.50"	1.50"	1150	713	413	516	2071	None
2 - Trimmer - DF	1.50"	1.50"	1.50"	1150	713	413	516	2071	None

Lateral Bracing	Bracing Intervals	Comments
Top Edge (Lu)	2' 6" o/c	
Bottom Edge (Lu)	2' 6" o/c	

•Maximum allowable bracing intervals based on applied load.

Vertical Loads	Location	Tributary Width	Dead (0.90)	Floor Live (1.00)	Roof Live (1.25)	Snow (1.15)	Comments
0 - Self Weight (PLF)	0 to 2' 6"	N/A	6.4	--	--	--	
1 - Uniform (PSF)	0 to 2' 6"	16' 6"	25.0	--	20.0	25.0	ROOF
2 - Uniform (PSF)	0 to 2' 6"	9'	12.0	--	--	--	4TH LEVEL WALL
3 - Uniform (PSF)	0 to 2' 6"	6' 3"	20.0	40.0	--	--	4TH LEVEL FLOOR
4 - Uniform (PSF)	0 to 2' 6"	9'	12.0	--	--	--	3RD LEVEL WALL
5 - Uniform (PSF)	0 to 2' 6"	8'	20.0	40.0	--	--	3RD LEVEL FLOOR

Weyerhaeuser Notes

Weyerhaeuser warrants that the sizing of its products will be in accordance with Weyerhaeuser product design criteria and published design values. Weyerhaeuser expressly disclaims any other warranties related to the software. Use of this software is not intended to circumvent the need for a design professional as determined by the authority having jurisdiction. The designer of record, builder or framer is responsible to assure that this calculation is compatible with the overall project. Accessories (Rim Board, Blocking Panels and Squash Blocks) are not designed by this software. Products manufactured at Weyerhaeuser facilities are third-party certified to sustainable forestry standards. Weyerhaeuser Engineered Lumber Products have been evaluated by ICC-ES under evaluation reports ESR-1153 and ESR-1387 and/or tested in accordance with applicable ASTM standards. For current code evaluation reports, Weyerhaeuser product literature and installation details refer to www.weyerhaeuser.com/woodproducts/document-library.

The product application, input design loads, dimensions and support information have been provided by ForteWEB Software Operator

ForteWEB Software Operator	Job Notes
Royal Mortier PLIRIS (509) 530-8713 royalm@mortierang.com	



2ND LEVEL, 2.25'-REAR WINDOW (PT LD ABV)
1 piece(s) 5 1/2" x 7 1/2" 24F-V4 DF Glulam

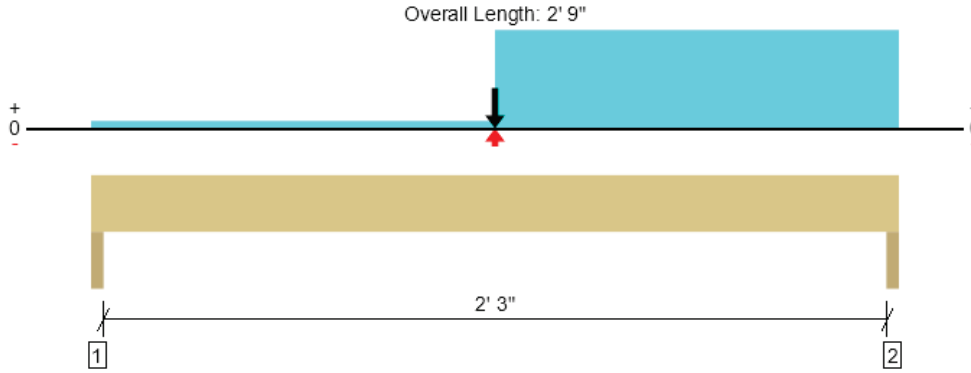

Drawing is Conceptual. All locations are measured from the outside face of left support (or left cantilever end). All dimensions are horizontal (typ.).

Design Results	Actual @ Location	Allowed	Result	LDF	Load: Combination (Pattern)
Member Reaction (lbs)	7406 @ 2' 7 1/2"	10725 (3.00")	Passed (69%)	--	1.0 D + 1.0 L (All Spans)
Shear (lbs)	6252 @ 10 1/2"	7288	Passed (86%)	1.00	1.0 D + 1.0 L (All Spans)
Pos Moment (Ft-lbs)	7843 @ 1' 4 1/2"	10313	Passed (76%)	1.00	1.0 D + 1.0 L (All Spans)
Live Load Defl. (in)	0.012 @ 1' 4 9/16"	0.083	Passed (L/999+)	--	1.0 D + 1.0 L (All Spans)
Total Load Defl. (in)	0.021 @ 1' 4 5/8"	0.125	Passed (L/999+)	--	1.0 D + 1.0 L (All Spans)

Member Length : 2' 9"
 System : Wall
 Member Type : Header
 Building Use : Commercial
 Building Code : IBC 2021
 Design Methodology : ASD

- Deflection criteria: LL (L/360) and TL (L/240).
- Allowed moment does not reflect the adjustment for the beam stability factor.
- Volume factor of 1.00 was calculated for positive bending using length L = 2' 6".
- The effects of positive or negative camber have not been accounted for when calculating deflection.
- The specified glulam is assumed to have its strong laminations at the bottom of the beam. Install with proper side up as indicated by the manufacturer.
- Applicable calculations are based on NDS.

Supports	Bearing Length			Loads to Supports (lbs)					Accessories
	Total	Available	Required	Dead	Floor Live	Roof Live	Snow	Factored	
1 - Trimmer - DF	3.00"	3.00"	1.79"	2727	3681	341	276	6408	None
2 - Trimmer - DF	3.00"	3.00"	2.07"	3320	4086	588	586	7406	None

Lateral Bracing	Bracing Intervals	Comments
Top Edge (Lu)	2' 9" o/c	
Bottom Edge (Lu)	2' 9" o/c	

•Maximum allowable bracing intervals based on applied load.

Vertical Loads	Location	Tributary Width	Dead (0.90)	Floor Live (1.00)	Roof Live (1.25)	Snow (1.15)	Comments
0 - Self Weight (PLF)	0 to 2' 9"	N/A	10.0	--	--	--	
1 - Uniform (PSF)	1' 4 1/2" to 2' 9"	16' 6"	25.0	--	20.0	25.0	ROOF
2 - Point (lb)	1' 4 1/2"	N/A	635	--	475	595	REAR WINDOW (4TH LEVEL)
3 - Point (lb)	1' 4 1/2"	N/A	1885	3415	--	-150	15.5'-FLOOR BEAM (4TH LEVEL)
4 - Uniform (PSF)	1' 4 1/2" to 2' 9"	9'	12.0	--	--	--	4TH LEVEL WALL
5 - Uniform (PSF)	1' 4 1/2" to 2' 9"	6' 3"	20.0	40.0	--	--	4TH LEVEL FLOOR
6 - Point (lb)	1' 4 1/2"	N/A	385	460	--	--	REAR WINDOW (3RD LEVEL)
7 - Uniform (PSF)	0 to 2' 9"	9'	12.0	--	--	--	3RD LEVEL WALL
8 - Point (lb)	1' 4 1/2"	N/A	1675	3040	--	-150	15.5'-FLOOR BEAM (3RD LEVEL)
9 - Uniform (PSF)	0 to 1' 4 1/2"	1'	20.0	40.0	--	--	3RD LEVEL FLOOR
10 - Uniform (PSF)	1' 4 1/2" to 2' 9"	8' 3"	20.0	40.0	--	--	3RD LEVEL FLOOR

Forteweb Software Operator	Job Notes
Royal Mortier PLIRIS (509) 530-8713 royalm@mortierang.com	



Weyerhaeuser Notes

Weyerhaeuser warrants that the sizing of its products will be in accordance with Weyerhaeuser product design criteria and published design values. Weyerhaeuser expressly disclaims any other warranties related to the software. Use of this software is not intended to circumvent the need for a design professional as determined by the authority having jurisdiction. The designer of record, builder or framer is responsible to assure that this calculation is compatible with the overall project. Accessories (Rim Board, Blocking Panels and Squash Blocks) are not designed by this software. Products manufactured at Weyerhaeuser facilities are third-party certified to sustainable forestry standards. Weyerhaeuser Engineered Lumber Products have been evaluated by ICC-ES under evaluation reports ESR-1153 and ESR-1387 and/or tested in accordance with applicable ASTM standards. For current code evaluation reports, Weyerhaeuser product literature and installation details refer to www.weyerhaeuser.com/woodproducts/document-library.

The product application, input design loads, dimensions and support information have been provided by ForteWEB Software Operator

ForteWEB Software Operator	Job Notes
Royal Mortier PLIRIS (509) 530-8713 royalm@mortierang.com	



2ND LEVEL, 3'3/3'- SIDE BALCONY WINDOW/DOOR
1 piece(s) 4 x 8 DF No.2

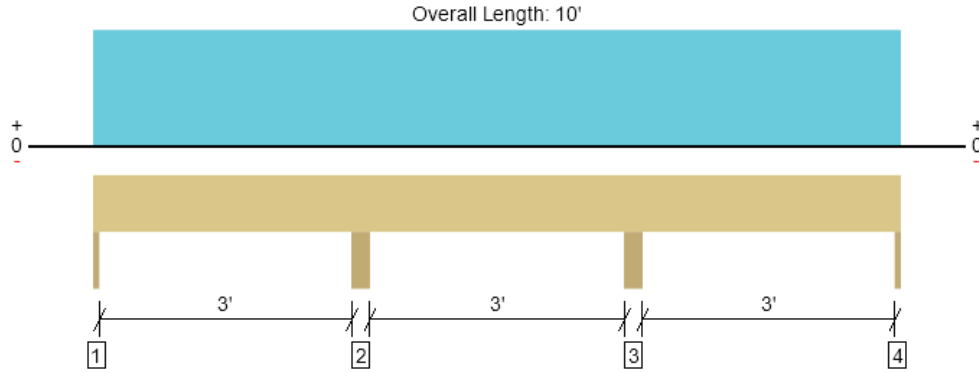

Drawing is Conceptual. All locations are measured from the outside face of left support (or left cantilever end). All dimensions are horizontal (typ.).

Design Results	Actual @ Location	Allowed	Result	LDF	Load: Combination (Pattern)
Member Reaction (lbs)	323 @ 0	3281 (1.50")	Passed (10%)	--	1.0 D + 1.0 L (Alt Spans)
Shear (lbs)	286 @ 2' 6 1/4"	3045	Passed (9%)	1.00	1.0 D + 1.0 L (Adj Spans)
Moment (Ft-lbs)	-276 @ 1' 7 5/16"	2989	Passed (9%)	1.00	1.0 D + 1.0 L (Adj Spans)
Live Load Defl. (in)	0.001 @ 1' 7 5/16"	0.110	Passed (L/999+)	--	1.0 D + 1.0 L (Alt Spans)
Total Load Defl. (in)	0.002 @ 8' 5 5/16"	0.166	Passed (L/999+)	--	1.0 D + 1.0 L (Alt Spans)

Member Length : 10'
 System : Wall
 Member Type : Header
 Building Use : Commercial
 Building Code : IBC 2021
 Design Methodology : ASD

- Deflection criteria: LL (L/360) and TL (L/240).
- Allowed moment does not reflect the adjustment for the beam stability factor.
- Applicable calculations are based on NDS.

Supports	Bearing Length			Loads to Supports (lbs)			Accessories
	Total	Available	Required	Dead	Floor Live	Factored	
1 - Trimmer - DF	1.50"	1.50"	1.50"	204	119/-14	323	None
2 - Trimmer - SPF	4.50"	4.50"	1.50"	568	320	889	None
3 - Trimmer - SPF	4.50"	4.50"	1.50"	568	320	889	None
4 - Trimmer - DF	1.50"	1.50"	1.50"	204	119/-14	323	None

Lateral Bracing	Bracing Intervals	Comments
Top Edge (Lu)	10' o/c	
Bottom Edge (Lu)	10' o/c	

•Maximum allowable bracing intervals based on applied load.

Vertical Loads	Location	Tributary Width	Dead (0.90)	Floor Live (1.00)	Comments
0 - Self Weight (PLF)	0 to 10'	N/A	6.4	--	
1 - Uniform (PSF)	0 to 10'	9'	12.0	--	3RD LEVEL WALL
2 - Uniform (PSF)	0 to 10'	2'	20.0	40.0	3RD LEVEL FLOOR

Weyerhaeuser Notes

Weyerhaeuser warrants that the sizing of its products will be in accordance with Weyerhaeuser product design criteria and published design values. Weyerhaeuser expressly disclaims any other warranties related to the software. Use of this software is not intended to circumvent the need for a design professional as determined by the authority having jurisdiction. The designer of record, builder or framer is responsible to assure that this calculation is compatible with the overall project. Accessories (Rim Board, Blocking Panels and Squash Blocks) are not designed by this software. Products manufactured at Weyerhaeuser facilities are third-party certified to sustainable forestry standards. Weyerhaeuser Engineered Lumber Products have been evaluated by ICC-ES under evaluation reports ESR-1153 and ESR-1387 and/or tested in accordance with applicable ASTM standards. For current code evaluation reports, Weyerhaeuser product literature and installation details refer to www.woyherhaeuser.com/woodproducts/document-library.

The product application, input design loads, dimensions and support information have been provided by ForteWEB Software Operator

ForteWEB Software Operator	Job Notes
Royal Mortier PLIRIS (509) 530-8713 royalm@mortierang.com	



2ND LEVEL FLOOR FRAMING, 18.5'-CANT. FLOOR BEAM
1 piece(s) 5 1/2" x 11 7/8" 24F-V4 DF Glulam

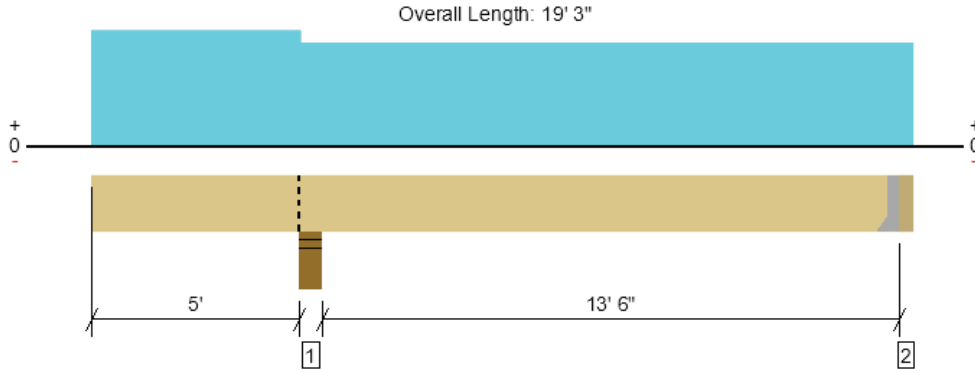

Drawing is Conceptual. All locations are measured from the outside face of left support (or left cantilever end). All dimensions are horizontal (typ.).

Design Results	Actual @ Location	Allowed	Result	LDF	Load: Combination (Pattern)
Member Reaction (lbs)	3534 @ 18' 11 1/2"	5363 (1.50")	Passed (66%)	--	1.0 D + 1.0 L (Alt Spans)
Shear (lbs)	3403 @ 6' 5 3/8"	11539	Passed (29%)	1.00	1.0 D + 1.0 L (All Spans)
Pos Moment (Ft-lbs)	11876 @ 12' 2 7/8"	25853	Passed (46%)	1.00	1.0 D + 1.0 L (Alt Spans)
Neg Moment (Ft-lbs)	-5962 @ 5' 2 3/4"	19928	Passed (30%)	1.00	1.0 D + 1.0 L (All Spans)
Live Load Defl. (in)	0.201 @ 0	0.349	Passed (2L/624)	--	1.0 D + 0.75 L + 0.75 S (Alt Spans)
Total Load Defl. (in)	0.289 @ 12' 1 3/4"	0.686	Passed (L/570)	--	1.0 D + 1.0 L (Alt Spans)

Member Length : 18' 11 1/2"
 System : Floor
 Member Type : Flush Beam
 Building Use : Commercial
 Building Code : IBC 2021
 Design Methodology : ASD

- Deflection criteria: LL (L/360) and TL (L/240).
- Overhang deflection criteria: LL (2L/360) and TL (2L/240).
- Allowed moment does not reflect the adjustment for the beam stability factor.
- Volume factor of 1.00 was calculated for positive bending using length L = 13' 5 5/16".
- Volume factor of 1.00 was calculated for negative bending using length L = 6' 10 9/16".
- The effects of positive or negative camber have not been accounted for when calculating deflection.
- The specified glulam is assumed to have its strong laminations at the bottom of the beam. Install with proper side up as indicated by the manufacturer.
- Applicable calculations are based on NDS.

Supports	Bearing Length			Loads to Supports (lbs)				Accessories
	Total	Available	Required	Dead	Floor Live	Snow	Factored	
1 - Stud wall - DF	5.50"	5.50"	1.85"	1774	4570	899	6344	Blocking
2 - Hanger on 11 7/8" DF beam	3.50"	Hanger ¹	1.50"	1250	2433/-259	-149	3683	See note ¹

- Blocking Panels are assumed to carry no loads applied directly above them and the full load is applied to the member being designed.
- At hanger supports, the Total Bearing dimension is equal to the width of the material that is supporting the hanger
- ¹ See Connector grid below for additional information and/or requirements.

Lateral Bracing	Bracing Intervals	Comments
Top Edge (Lu)	19' o/c	
Bottom Edge (Lu)	19' o/c	

•Maximum allowable bracing intervals based on applied load.

Connector: Simpson Strong-Tie						
Support	Model	Seat Length	Top Fasteners	Face Fasteners	Member Fasteners	Accessories
2 - Face Mount Hanger	HU614	2.50"	N/A	24-16d	12-16d	

• Refer to manufacturer notes and instructions for proper installation and use of all connectors.

Vertical Loads	Location (Side)	Tributary Width	Dead (0.90)	Floor Live (1.00)	Snow (1.15)	Comments
0 - Self Weight (PLF)	0 to 18' 11 1/2"	N/A	15.9	--	--	
1 - Uniform (PSF)	0 to 5' (Front)	6'	10.0	60.0	25.0	BALCONY
2 - Uniform (PSF)	5' to 19' 3" (Front)	8' 6"	20.0	40.0	--	FLOOR

• Side loads are assumed to not induce cross-grain tension.

ForTEWEB Software Operator	Job Notes
Royal Mortier PLIRIS (509) 530-8713 royalm@mortierang.com	



Weyerhaeuser Notes

Weyerhaeuser warrants that the sizing of its products will be in accordance with Weyerhaeuser product design criteria and published design values. Weyerhaeuser expressly disclaims any other warranties related to the software. Use of this software is not intended to circumvent the need for a design professional as determined by the authority having jurisdiction. The designer of record, builder or framer is responsible to assure that this calculation is compatible with the overall project. Accessories (Rim Board, Blocking Panels and Squash Blocks) are not designed by this software. Products manufactured at Weyerhaeuser facilities are third-party certified to sustainable forestry standards. Weyerhaeuser Engineered Lumber Products have been evaluated by ICC-ES under evaluation reports ESR-1153 and ESR-1387 and/or tested in accordance with applicable ASTM standards. For current code evaluation reports, Weyerhaeuser product literature and installation details refer to www.weyerhaeuser.com/woodproducts/document-library.

The product application, input design loads, dimensions and support information have been provided by ForteWEB Software Operator

ForteWEB Software Operator	Job Notes
Royal Mortier PLIRIS (509) 530-8713 royalm@mortierang.com	



2ND LEVEL FLOOR FRAMING, 15.5'-FLOOR BEAM
1 piece(s) 5 1/2" x 11 7/8" 24F-V4 DF Glulam

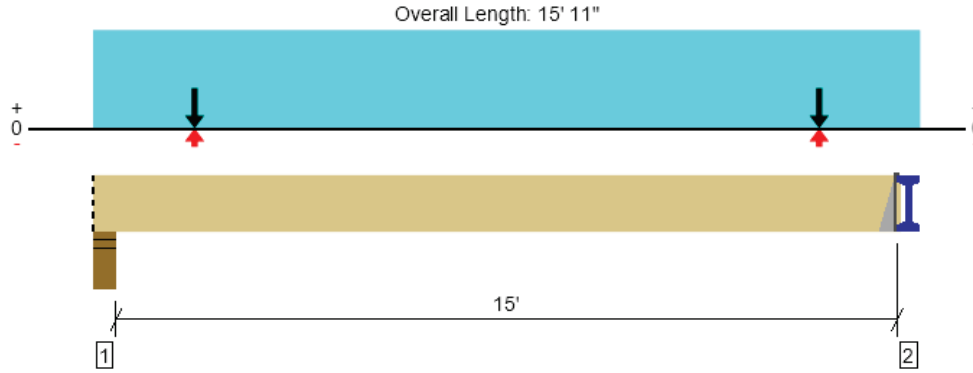

Drawing is Conceptual. All locations are measured from the outside face of left support (or left cantilever end). All dimensions are horizontal (typ.).

Design Results	Actual @ Location	Allowed	Result	LDF	Load: Combination (Pattern)
Member Reaction (lbs)	4768 @ 15' 5 1/2"	5363 (1.50")	Passed (89%)	--	1.0 D + 1.0 L (All Spans)
Shear (lbs)	4634 @ 14' 5 5/8"	11539	Passed (40%)	1.00	1.0 D + 1.0 L (All Spans)
Pos Moment (Ft-lbs)	9661 @ 7' 6 1/4"	25853	Passed (37%)	1.00	1.0 D + 1.0 L (All Spans)
Live Load Defl. (in)	0.203 @ 7' 10 1/4"	0.504	Passed (L/896)	--	1.0 D + 1.0 L (All Spans)
Total Load Defl. (in)	0.319 @ 7' 10 1/4"	0.756	Passed (L/569)	--	1.0 D + 1.0 L (All Spans)

Member Length : 15' 5 1/2"
 System : Floor
 Member Type : Flush Beam
 Building Use : Commercial
 Building Code : IBC 2021
 Design Methodology : ASD

- Deflection criteria: LL (L/360) and TL (L/240).
- Allowed moment does not reflect the adjustment for the beam stability factor.
- Volume factor of 1.00 was calculated for positive bending using length L = 15' 1 1/2".
- The effects of positive or negative camber have not been accounted for when calculating deflection.
- The specified glulam is assumed to have its strong laminations at the bottom of the beam. Install with proper side up as indicated by the manufacturer.
- Applicable calculations are based on NDS.

Supports	Bearing Length			Loads to Supports (lbs)				Accessories
	Total	Available	Required	Dead	Floor Live	Snow	Factored	
1 - Stud wall - DF	5.50"	5.50"	1.50"	1674	3038	-148	4712	Blocking
2 - Hanger on steel	5.50"	Hanger ¹	1.50"	1708	3115	-152	4823	See note ¹

- Blocking Panels are assumed to carry no loads applied directly above them and the full load is applied to the member being designed.
- At hanger supports, the Total Bearing dimension is equal to the width of the material that is supporting the hanger
- ¹ See Connector grid below for additional information and/or requirements.

Lateral Bracing	Bracing Intervals	Comments
Top Edge (Lu)	15' 6" o/c	
Bottom Edge (Lu)	15' 6" o/c	

•Maximum allowable bracing intervals based on applied load.

Connector: Simpson Strong-Tie						
Support	Model	Seat Length	Top Fasteners	Face Fasteners	Member Fasteners	Accessories
2 - Top Mount Hanger	HB5.50X H=11.875	3.50"	4-1/8 WELD	N/A	10-16d	

• Refer to manufacturer notes and instructions for proper installation and use of all connectors.

Vertical Loads	Location (Side)	Tributary Width	Dead (0.90)	Floor Live (1.00)	Snow (1.15)	Comments
0 - Self Weight (PLF)	0 to 15' 5 1/2"	N/A	15.9	--	--	
1 - Point (lb)	2' (Back)	N/A	1250	2440	-150	18.5'-CANT. FLOOR BEAM
2 - Point (lb)	14' (Back)	N/A	1250	2440	-150	18.5'-CANT. FLOOR BEAM
3 - Uniform (PSF)	0 to 15' 11" (Front)	2'	20.0	40.0	--	FLOOR

• Side loads are assumed to not induce cross-grain tension.

Forteweb Software Operator	Job Notes
Royal Mortier PLIRIS (509) 530-8713 royalm@mortierang.com	



Weyerhaeuser Notes

Weyerhaeuser warrants that the sizing of its products will be in accordance with Weyerhaeuser product design criteria and published design values. Weyerhaeuser expressly disclaims any other warranties related to the software. Use of this software is not intended to circumvent the need for a design professional as determined by the authority having jurisdiction. The designer of record, builder or framer is responsible to assure that this calculation is compatible with the overall project. Accessories (Rim Board, Blocking Panels and Squash Blocks) are not designed by this software. Products manufactured at Weyerhaeuser facilities are third-party certified to sustainable forestry standards. Weyerhaeuser Engineered Lumber Products have been evaluated by ICC-ES under evaluation reports ESR-1153 and ESR-1387 and/or tested in accordance with applicable ASTM standards. For current code evaluation reports, Weyerhaeuser product literature and installation details refer to www.weyerhaeuser.com/woodproducts/document-library.

The product application, input design loads, dimensions and support information have been provided by ForteWEB Software Operator

ForteWEB Software Operator	Job Notes
Royal Mortier PLIRIS (509) 530-8713 royalm@mortierang.com	



2ND LEVEL FLOOR FRAMING, 14'-FLOOR BEAM
1 piece(s) 5 1/2" x 16 1/2" 24F-V4 DF Glulam

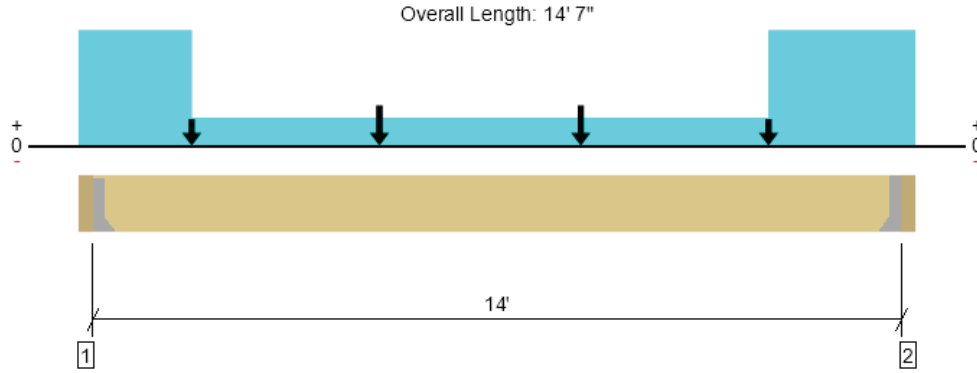

Drawing is Conceptual. All locations are measured from the outside face of left support (or left cantilever end). All dimensions are horizontal (typ.).

Design Results	Actual @ Location	Allowed	Result	LDF	Load: Combination (Pattern)
Member Reaction (lbs)	12430 @ 14' 3 1/2"	12430 (3.48")	Passed (100%)	--	1.0 D + 0.75 L + 0.75 Lr (All Spans)
Shear (lbs)	9155 @ 12' 11"	18437	Passed (50%)	1.15	1.0 D + 0.75 L + 0.75 S (All Spans)
Pos Moment (Ft-lbs)	40957 @ 8' 1/4"	62391	Passed (66%)	1.25	1.0 D + 0.75 L + 0.75 Lr (All Spans)
Live Load Defl. (in)	0.195 @ 7' 3 9/16"	0.467	Passed (L/861)	--	1.0 D + 0.75 L + 0.75 Lr (All Spans)
Total Load Defl. (in)	0.394 @ 7' 3 5/8"	0.700	Passed (L/426)	--	1.0 D + 0.75 L + 0.75 Lr (All Spans)

Member Length : 14'
 System : Floor
 Member Type : Flush Beam
 Building Use : Commercial
 Building Code : IBC 2021
 Design Methodology : ASD

- Deflection criteria: LL (L/360) and TL (L/240).
- Allowed moment does not reflect the adjustment for the beam stability factor.
- Volume factor of 1.00 was calculated for positive bending using length L = 14'.
- The effects of positive or negative camber have not been accounted for when calculating deflection.
- The specified glulam is assumed to have its strong laminations at the bottom of the beam. Install with proper side up as indicated by the manufacturer.
- Applicable calculations are based on NDS.

Supports	Bearing Length			Loads to Supports (lbs)					Accessories
	Total	Available	Required	Dead	Floor Live	Roof Live	Snow	Factored	
1 - Hanger on 16 1/2" DF beam	3.50"	Hanger ¹	3.46"	6607	3937	4474	3643	12916	See note ¹
2 - Hanger on 16 1/2" DF beam	3.50"	Hanger ¹	3.48"	6652	4113	4306	3647	12966	See note ¹

- At hanger supports, the Total Bearing dimension is equal to the width of the material that is supporting the hanger
- ¹ See Connector grid below for additional information and/or requirements.

Lateral Bracing	Bracing Intervals	Comments
Top Edge (Lu)	14' o/c	
Bottom Edge (Lu)	14' o/c	

•Maximum allowable bracing intervals based on applied load.

Connector: Simpson Strong-Tie						
Support	Model	Seat Length	Top Fasteners	Face Fasteners	Member Fasteners	Accessories
1 - Face Mount Hanger	HGUS5.50/12	4.00"	N/A	56-16d	20-16d	
2 - Face Mount Hanger	HGUS5.50/12	4.00"	N/A	56-16d	20-16d	

- Refer to manufacturer notes and instructions for proper installation and use of all connectors.

ForTEWEB Software Operator	Job Notes
Royal Mortier PLIRIS (509) 530-8713 royalm@mortierang.com	



Vertical Loads	Location (Side)	Tributary Width	Dead (0.90)	Floor Live (1.00)	Roof Live (1.25)	Snow (1.15)	Comments
0 - Self Weight (PLF)	3 1/2" to 14' 3 1/2"	N/A	22.1	--	--	--	
1 - Point (lb)	2' (Top)	N/A	675	--	530	660	3'-FRONT WINDOW (BALCONY) - 3RD LEVEL
2 - Point (lb)	5' 3" (Top)	N/A	1350	--	1060	1320	3'-FRONT WINDOW (BALCONY) - 3RD LEVEL
3 - Point (lb)	8' 9" (Top)	N/A	1350	--	1060	1320	3'-FRONT WINDOW (BALCONY) - 3RD LEVEL
4 - Point (lb)	12' (Top)	N/A	675	--	530	660	3'-FRONT WINDOW (BALCONY) - 3RD LEVEL
5 - Point (lb)	2' (Top)	N/A	465	--	685	85	3'-FRONT WINDOW (BALCONY) - 2ND LEVEL
6 - Point (lb)	5' 3" (Top)	N/A	930	--	1370	170	3'-FRONT WINDOW (BALCONY) - 2ND LEVEL
7 - Point (lb)	8' 9" (Top)	N/A	930	--	1370	170	3'-FRONT WINDOW (BALCONY) - 2ND LEVEL
8 - Point (lb)	12' (Top)	N/A	465	--	685	85	3'-FRONT WINDOW (BALCONY) - 2ND LEVEL
9 - Uniform (PSF)	0 to 2' (Top)	16' 3"	25.0	--	20.0	25.0	ROOF
10 - Uniform (PSF)	12' to 14' 7" (Top)	16' 3"	25.0	--	20.0	25.0	ROOF
11 - Uniform (PSF)	0 to 2' (Front)	9'	12.0	--	--	--	3RD LEVEL WALL
12 - Uniform (PSF)	12' to 14' 7" (Front)	9'	12.0	--	--	--	3RD LEVEL WALL
13 - Uniform (PSF)	0 to 2' (Front)	7' 6"	20.0	40.0	--	--	3RD LEVEL FLOOR
14 - Uniform (PSF)	12' to 14' 7" (Front)	7' 6"	20.0	40.0	--	--	3RD LEVEL FLOOR
15 - Uniform (PSF)	0 to 2' (Front)	2'	10.0	60.0	--	25.0	3RD LEVEL BALCONY
16 - Uniform (PSF)	12' to 14' 7" (Front)	2'	10.0	60.0	--	25.0	3RD LEVEL BALCONY
17 - Uniform (PSF)	0 to 2' (Front)	9'	12.0	--	--	--	2ND LEVEL WALL
18 - Uniform (PSF)	12' to 14' 7" (Front)	9'	12.0	--	--	--	2ND LEVEL WALL
19 - Uniform (PSF)	0 to 14' 7" (Front)	7' 6"	20.0	40.0	--	--	2ND LEVEL FLOOR
20 - Uniform (PSF)	0 to 14' 7" (Front)	2'	10.0	60.0	--	25.0	2ND LEVEL BALCONY

• Side loads are assumed to not induce cross-grain tension.

Weyerhaeuser Notes

Weyerhaeuser warrants that the sizing of its products will be in accordance with Weyerhaeuser product design criteria and published design values. Weyerhaeuser expressly disclaims any other warranties related to the software. Use of this software is not intended to circumvent the need for a design professional as determined by the authority having jurisdiction. The designer of record, builder or framer is responsible to assure that this calculation is compatible with the overall project. Accessories (Rim Board, Blocking Panels and Squash Blocks) are not designed by this software. Products manufactured at Weyerhaeuser facilities are third-party certified to sustainable forestry standards. Weyerhaeuser Engineered Lumber Products have been evaluated by ICC-ES under evaluation reports ESR-1153 and ESR-1387 and/or tested in accordance with applicable ASTM standards. For current code evaluation reports, Weyerhaeuser product literature and installation details refer to www.weyerhaeuser.com/woodproducts/document-library.

The product application, input design loads, dimensions and support information have been provided by ForteWEB Software Operator

ForteWEB Software Operator	Job Notes
Royal Mortier PLIRIS (509) 530-8713 royalm@mortierang.com	



2ND LEVEL FLOOR FRAMING, 18.5'-FLOOR BEAM
1 piece(s) 5 1/2" x 16 1/2" 24F-V4 DF Glulam

Drawing is Conceptual. All locations are measured from the outside face of left support (or left cantilever end). All dimensions are horizontal (typ.).

Design Results	Actual @ Location	Allowed	Result	LDF	Load: Combination (Pattern)
Member Reaction (lbs)	3663 @ 18' 11 1/2"	5363 (1.50")	Passed (68%)	--	1.0 D + 0.75 L + 0.75 Lr (All Spans)
Shear (lbs)	9306 @ 1' 10"	16033	Passed (58%)	1.00	1.0 D + 1.0 L (All Spans)
Pos Moment (Ft-lbs)	38051 @ 4' 6"	48587	Passed (78%)	1.00	1.0 D + 1.0 L (All Spans)
Live Load Defl. (in)	0.274 @ 8' 7 3/16"	0.621	Passed (L/815)	--	1.0 D + 0.75 L + 0.75 Lr (All Spans)
Total Load Defl. (in)	0.588 @ 8' 7 5/16"	0.931	Passed (L/380)	--	1.0 D + 0.75 L + 0.75 Lr (All Spans)

Member Length : 18' 11 1/2"
 System : Floor
 Member Type : Flush Beam
 Building Use : Commercial
 Building Code : IBC 2021
 Design Methodology : ASD

- Deflection criteria: LL (L/360) and TL (L/240).
- Allowed moment does not reflect the adjustment for the beam stability factor.
- Volume factor of 0.97 was calculated for positive bending using length L = 18' 7 1/2".
- The effects of positive or negative camber have not been accounted for when calculating deflection.
- The specified glulam is assumed to have its strong laminations at the bottom of the beam. Install with proper side up as indicated by the manufacturer.
- Applicable calculations are based on NDS.

Supports	Bearing Length			Loads to Supports (lbs)					Accessories
	Total	Available	Required	Dead	Floor Live	Roof Live	Snow	Factored	
1 - Stud wall - DF	5.50"	5.50"	3.37"	6408	3444	3478	2833	11600	Blocking
2 - Hanger on steel	3.50"	Hanger ¹	1.50"	1977	1266	1002	817	3678	See note ¹

- Blocking Panels are assumed to carry no loads applied directly above them and the full load is applied to the member being designed.
- At hanger supports, the Total Bearing dimension is equal to the width of the material that is supporting the hanger
- ¹ See Connector grid below for additional information and/or requirements.

Lateral Bracing	Bracing Intervals	Comments
Top Edge (Lu)	19' o/c	
Bottom Edge (Lu)	19' o/c	

•Maximum allowable bracing intervals based on applied load.

Connector: Simpson Strong-Tie						
Support	Model	Seat Length	Top Fasteners	Face Fasteners	Member Fasteners	Accessories
2 - Top Mount Hanger	BA5.50X H=16.5	3.00"	6-PDPAT-62KP	N/A	2-10dx1.5	

• Refer to manufacturer notes and instructions for proper installation and use of all connectors.

Vertical Loads	Location (Side)	Tributary Width	Dead (0.90)	Floor Live (1.00)	Roof Live (1.25)	Snow (1.15)	Comments
0 - Self Weight (PLF)	0 to 18' 11 1/2"	N/A	22.1	--	--	--	
1 - Uniform (PSF)	0 to 4' 6" (Front)	9'	12.0	--	--	--	3RD LEVEL WALL
2 - Uniform (PSF)	0 to 4' 6" (Front)	9'	12.0	--	--	--	2ND LEVEL WALL
3 - Point (lb)	4' 6" (Front)	N/A	6610	3940	4480	3650	14'-FLOOR BEAM
4 - Uniform (PSF)	0 to 19' 3" (Front)	1'	20.0	40.0	--	--	2ND LEVEL FLOOR

• Side loads are assumed to not induce cross-grain tension.

ForteWEB Software Operator	Job Notes
Royal Mortier PLIRIS (509) 530-8713 royalm@mortierang.com	



Weyerhaeuser Notes

Weyerhaeuser warrants that the sizing of its products will be in accordance with Weyerhaeuser product design criteria and published design values. Weyerhaeuser expressly disclaims any other warranties related to the software. Use of this software is not intended to circumvent the need for a design professional as determined by the authority having jurisdiction. The designer of record, builder or framer is responsible to assure that this calculation is compatible with the overall project. Accessories (Rim Board, Blocking Panels and Squash Blocks) are not designed by this software. Products manufactured at Weyerhaeuser facilities are third-party certified to sustainable forestry standards. Weyerhaeuser Engineered Lumber Products have been evaluated by ICC-ES under evaluation reports ESR-1153 and ESR-1387 and/or tested in accordance with applicable ASTM standards. For current code evaluation reports, Weyerhaeuser product literature and installation details refer to www.weyerhaeuser.com/woodproducts/document-library.

The product application, input design loads, dimensions and support information have been provided by ForteWEB Software Operator

ForteWEB Software Operator	Job Notes
Royal Mortier PLIRIS (509) 530-8713 royalm@mortierang.com	



Project Title:
 Engineer:
 Project ID:
 Project Descr:

Steel Beam

Project File:

LIC# : KW-06019737, Build:20.25.10.02

PLIRIS

(c) ENERCALC, LLC 1982-2025

DESCRIPTION: BEAM OVER GARAGE ENTRY

Code References

Governing Code : IBC 2021
 Referenced Design Standard(s) : AISC 360-16
 Load Combination Set : ASCE 7-22 / IBC 2024

Material Properties

Analysis Method : Allowable Strength Design
 Beam Bracing : Beam is Fully Braced against lateral-torsional buckling
 Bending Axis : Major Axis Bending
 Fy : Steel Yield : 50.0 ksi
 E : Modulus : 29,000.0 ksi

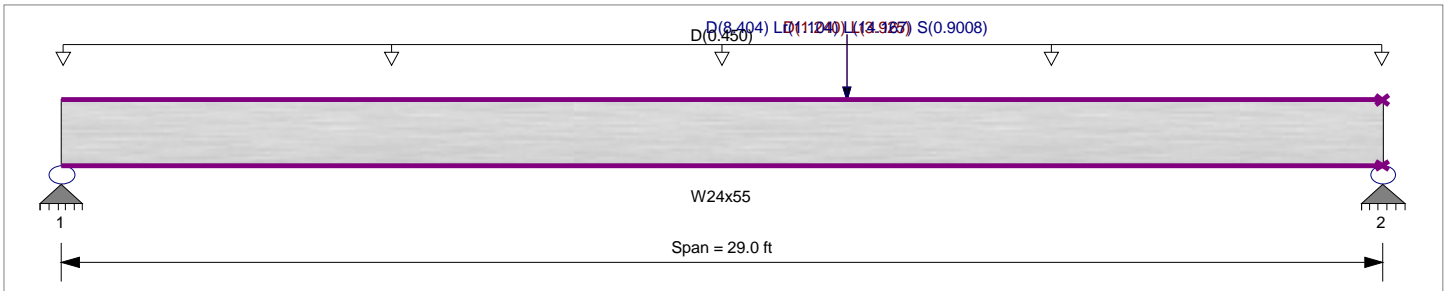

Applied Loads

Service loads entered. Load Factors will be applied for calculations.

Beam self weight calculated and added to loading
 Loads on all spans...
 Uniform Load on ALL spans : D = 0.0150 ksf, Tributary Width = 30.0 ft
 Load(s) for Span Number 1
 Point Load : D = 1.240, L = 3.925 k @ 17.250 ft, (3RD FLOOR FRAMING)
 Linked Load(s)
 Beam 2ND FLOOR - BEAM OVER GARAGE, Support 3: D = 8.404, Lr = 1.104, L = 14.167, S = 0.9008 k @ 17.25 ft from l

DESIGN SUMMARY

Design OK

Maximum Bending Stress Ratio =	0.732 : 1	Maximum Shear Stress Ratio =	0.142 : 1
Section used for this span	W24x55	Section used for this span	W24x55
Ma : Applied	244.880 k-ft	Va : Applied	23.821 k
Mn / Omega : Allowable	334.331 k-ft	Vn/Omega : Allowable	167.461 k
Load Combination		Load Combination	
		+D+L	+D+L
Span # where maximum occurs	Span # 1	Location of maximum on span	29.000 ft
		Span # where maximum occurs	Span # 1
Maximum Deflection			
Max Downward Transient Deflection	0.388 in Ratio = 895 >=360	Span: 1 : L Only	
Max Upward Transient Deflection	0 in Ratio = 0 <360	n/a	
Max Downward Total Deflection	0.801 in Ratio = 434 >=180	Span: 1 : +D+L	
Max Upward Total Deflection	0 in Ratio = 0 <180	n/a	

Maximum Forces & Stresses for Load Combinations

Load Combination	Segment Length	Span #	Max Stress Ratios		Summary of Moment Values					Summary of Shear Values				
			M	V	Mmax +	Mmax -	Ma Max	Mnx	Mnx/Omega	Cb	Rm	Va Max	Vnx	Vnx/Omega
D Only	Dsgn. L = 29.00 ft	1	0.355	0.078	118.54		118.54	558.33	334.33	1.00	1.00	13.06	279.66	167.46
+D+L	Dsgn. L = 29.00 ft	1	0.732	0.142	244.88		244.88	558.33	334.33	1.00	1.00	23.82	279.66	167.46
+D+Lr	Dsgn. L = 29.00 ft	1	0.378	0.082	126.25		126.25	558.33	334.33	1.00	1.00	13.72	279.66	167.46
+D+0.70S	Dsgn. L = 29.00 ft	1	0.368	0.080	122.95		122.95	558.33	334.33	1.00	1.00	13.43	279.66	167.46
+D+0.750Lr+0.750L	Dsgn. L = 29.00 ft	1	0.655	0.129	219.08		219.08	558.33	334.33	1.00	1.00	21.62	279.66	167.46
+D+0.750L+0.5250S	Dsgn. L = 29.00 ft	1	0.648	0.128	216.60		216.60	558.33	334.33	1.00	1.00	21.41	279.66	167.46
+0.60D	Dsgn. L = 29.00 ft	1	0.213	0.047	71.13		71.13	558.33	334.33	1.00	1.00	7.84	279.66	167.46
+D+0.750L+0.10S	Dsgn. L = 29.00 ft	1	0.640	0.127	213.92		213.92	558.33	334.33	1.00	1.00	21.18	279.66	167.46

Project Title:
 Engineer:
 Project ID:
 Project Descr:

Steel Beam

Project File:

LIC# : KW-06019737, Build:20.25.10.02

PLIRIS

(c) ENERCALC, LLC 1982-2025

DESCRIPTION: BEAM OVER GARAGE ENTRY

Overall Maximum Deflections

Span	Load Combination	Max. "-" Defl	Location in Span	Load Combination	Max. "+" Defl	Location in Span
1	+D+L	0.8011	15.163		0.0000	0.000

Vertical Reactions

Support notation : Far left is #

Values in KIPS

Load Combination	Support 1	Support 2	
Max Upward from all Load Conditions	18.561	23.821	0.901
Max Upward from Load Combinations	18.561	23.821	0.901
Max Upward from Load Cases	11.230	13.059	0.901
Max Downward from all Load Conditions (Resisting Uplift)			0.901
Max Downward from Load Combinations (Resisting Uplift)			0.901
Max Downward from Load Cases (Resisting Uplift)			0.901
D Only	11.230	13.059	0.901
+D+L	18.561	23.821	0.901
+D+Lr	11.677	13.716	0.901
+D+0.70S	11.485	13.434	0.901
+D+0.750Lr+0.750L	17.063	21.623	0.901
+D+0.750L+0.5250S	16.920	21.412	0.901
+0.60D	6.738	7.835	0.901
+D+0.750L+0.10S	16.764	21.184	0.901
Lr Only	0.447	0.657	0.901
L Only	7.331	10.762	0.901
S Only	0.365	0.536	0.901

Project Title:
 Engineer:
 Project ID:
 Project Descr:

Steel Beam

Project File:

LIC#: KW-06019737, Build:20.25.10.02

PLIRIS

(c) ENERCALC, LLC 1982-2025

DESCRIPTION: STEEL BEAM OVER COMMERCIAL SPACE

Code References

Governing Code : IBC 2021
 Referenced Design Standard(s) : AISC 360-16
 Load Combination Set : IBC 2018

Material Properties

Analysis Method : Allowable Strength Design
 Beam Bracing : Beam is Fully Braced against lateral-torsional buckling
 Bending Axis : Major Axis Bending
 Fy : Steel Yield : 50.0 ksi
 E: Modulus : 29,000.0 ksi

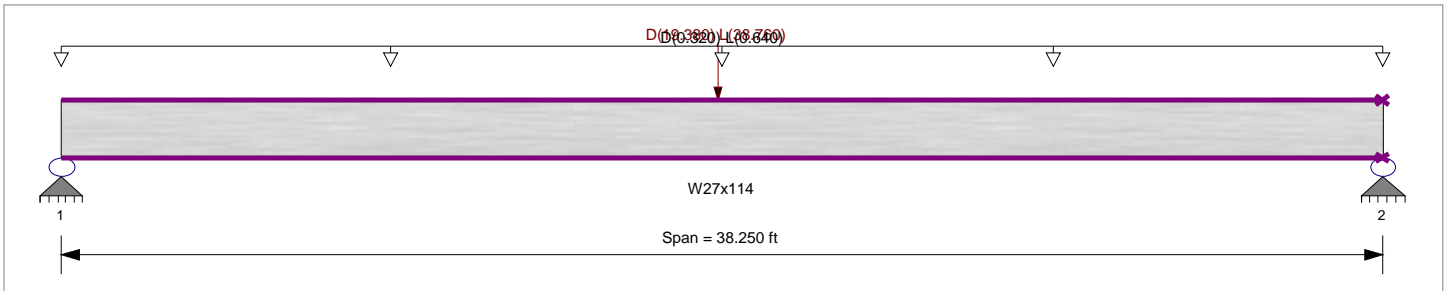

Applied Loads

Service loads entered. Load Factors will be applied for calculations.

Beam self weight calculated and added to loading
 Load(s) for Span Number 1
 Point Load : D = 19.380, L = 38.760 k @ 19.0 ft, (CONDOS)
 Uniform Load : D = 0.320, L = 0.640 k/ft, Tributary Width = 1.0 ft, (1ST FLOOR TRUSSES)

DESIGN SUMMARY

Design OK

Maximum Bending Stress Ratio =	0.879 : 1	Maximum Shear Stress Ratio =	0.160 : 1
Section used for this span	W27x114	Section used for this span	W27x114
Ma : Applied	751.896 k-ft	Va : Applied	49.80 k
Mn / Omega : Allowable	855.788 k-ft	Vn/Omega : Allowable	311.220 k
Load Combination		Load Combination	
	+D+L		+D+L
Span # where maximum occurs	Span # 1	Location of maximum on span	0.000 ft
		Span # where maximum occurs	Span # 1
Maximum Deflection			
Max Downward Transient Deflection	0.924 in Ratio = 496 >=360	Span: 1 : L Only	
Max Upward Transient Deflection	0 in Ratio = 0 <360	n/a	
Max Downward Total Deflection	1.433 in Ratio = 320 >=180	Span: 1 : +D+L	
Max Upward Total Deflection	0 in Ratio = 0 <180	n/a	

Maximum Forces & Stresses for Load Combinations

Load Combination	Segment Length	Span #	Max Stress Ratios		Summary of Moment Values						Summary of Shear Values				
			M	V	Mmax +	Mmax -	Ma Max	Mnx	Mnx/Omega	Cb	Rm	Va Max	Vnx	Vnx/Omega	
D Only															
Dsgn. L =	38.25 ft	1	0.309	0.058	264.53		264.53	1,429.17	855.79	1.00	1.00	18.05	466.83	311.22	
+D+L															
Dsgn. L =	38.25 ft	1	0.879	0.160	751.90		751.90	1,429.17	855.79	1.00	1.00	49.80	466.83	311.22	
+D+0.750L															
Dsgn. L =	38.25 ft	1	0.736	0.135	630.05		630.05	1,429.17	855.79	1.00	1.00	41.86	466.83	311.22	
+0.60D															
Dsgn. L =	38.25 ft	1	0.185	0.035	158.72		158.72	1,429.17	855.79	1.00	1.00	10.83	466.83	311.22	

Overall Maximum Deflections

Span	Load Combination	Max. "-" Defl	Location in Span	Load Combination	Max. "+" Defl	Location in Span
1	+D+L	1.4333	19.125		0.0000	0.000

Vertical Reactions

Support notation : Far left is #'

Values in KIPS

Load Combination	Support 1	Support 2
Max Upward from all Load Conditions	49.800	49.420
Max Upward from Load Combinations	49.800	49.420
Max Upward from Load Cases	31.747	31.493
D Only	18.054	17.927

Project Title:
Engineer:
Project ID:
Project Descr:

Steel Beam

Project File:

LIC# : KW-06019737, Build:20.25.10.02

PLIRIS

(c) ENERCALC, LLC 1982-2025

DESCRIPTION: STEEL BEAM OVER COMMERCIAL SPACE

Vertical Reactions

Support notation : Far left is #

Values in KIPS

Load Combination	Support 1	Support 2
+D+L	49.800	49.420
+D+0.750L	41.864	41.547
+0.60D	10.832	10.756
L Only	31.747	31.493

Steel Beam

Project File:

LIC#: KW-06019737, Build:20.25.10.02

PLIRIS

(c) ENERCALC, LLC 1982-2025

DESCRIPTION: 2ND FLOOR - BEAM OVER GARAGE

Code References

Governing Code : IBC 2021
 Referenced Design Standard(s) : AISC 360-16
 Load Combination Set : ASCE 7-22 / IBC 2024

Material Properties

Analysis Method : Allowable Strength Design
 Beam Bracing : Beam is Fully Braced against lateral-torsional buckling
 Bending Axis : Major Axis Bending
 Fy : Steel Yield : 50.0 ksi
 E : Modulus : 29,000.0 ksi

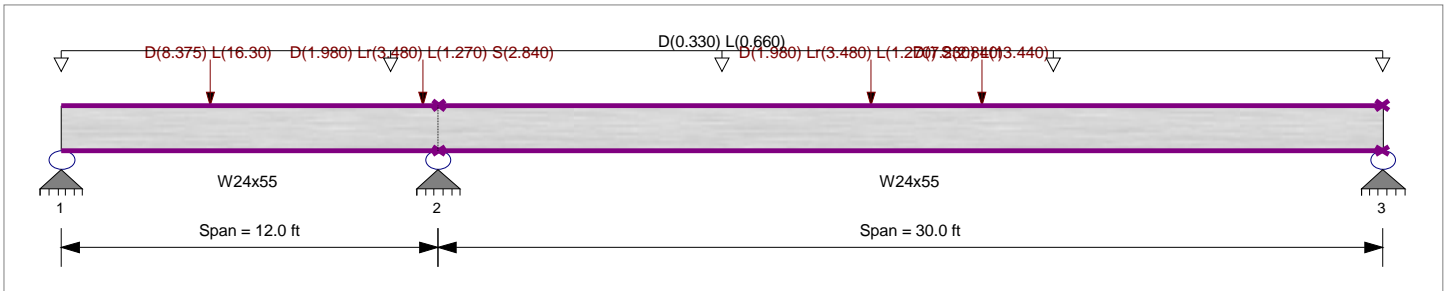

Applied Loads

Service loads entered. Load Factors will be applied for calculations.

Beam self weight calculated and added to loading
 Loads on all spans...

Uniform Load on ALL spans : D = 0.020, L = 0.040 ksf, Tributary Width = 16.50 ft

Load(s) for Span Number 1

Point Load : D = 8.375, L = 16.30 k @ 4.750 ft

Point Load : D = 1.980, Lr = 3.480, L = 1.270, S = 2.840 k @ 11.50 ft, (PERPENDICULAR FLOOR BEAM)

Load(s) for Span Number 2

Point Load : D = 1.980, Lr = 3.480, L = 1.270, S = 2.840 k @ 13.750 ft, (PERPENDICULAR BALCONY SUPPORT FLOOR)

Point Load : D = 7.230, L = 13.440 k @ 17.250 ft, (3RD FLOOR BEAM SUPPORT)

DESIGN SUMMARY

Design OK

Maximum Bending Stress Ratio = **0.606** : 1

Maximum Shear Stress Ratio = **0.211** : 1

Section used for this span **W24x55**
 Ma : Applied 202.569 k-ft
 Mn / Omega : Allowable 334.331 k-ft

Section used for this span **W24x55**
 Va : Applied 35.348 k
 Vn/Omega : Allowable 167.461 k

Load Combination

Load Combination

+D+L

+D+L

Span # where maximum occurs **Span # 2**

Location of maximum on span **12.000 ft**
 Span # where maximum occurs **Span # 1**

Maximum Deflection

Max Downward Transient Deflection 0.369 in Ratio = **974** >=360 Span: 2 : L Only
 Max Upward Transient Deflection -0.021 in Ratio = **6,941** >=360 Span: 1 : L Only
 Max Downward Total Deflection 0.595 in Ratio = **605** >=180 Span: 2 : +D+L
 Max Upward Total Deflection -0.035 in Ratio = **4139** >=180 Span: 1 : +D+L

Maximum Forces & Stresses for Load Combinations

Load Combination	Segment Length	Span #	Max Stress Ratios		Summary of Moment Values						Summary of Shear Values			
			M	V	Mmax +	Mmax -	Ma Max	Mnx	Mnx/Omega	Cb	Rm	Va Max	Vnx/Vnx/Omega	
D Only														
Dsgn. L = 12.00 ft		1	0.219	0.081	2.41	-73.07	73.07	558.33	334.33	1.00	1.00	13.61	279.66	167.46
Dsgn. L = 30.00 ft		2	0.227	0.074	75.75	-73.07	75.75	558.33	334.33	1.00	1.00	12.36	279.66	167.46
+D+L														
Dsgn. L = 12.00 ft		1	0.581	0.211	12.51	-194.35	194.35	558.33	334.33	1.00	1.00	35.35	279.66	167.46
Dsgn. L = 30.00 ft		2	0.606	0.195	202.57	-194.35	202.57	558.33	334.33	1.00	1.00	32.70	279.66	167.46
+D+Lr														
Dsgn. L = 12.00 ft		1	0.263	0.109	0.10	-87.81	87.81	558.33	334.33	1.00	1.00	18.17	279.66	167.46
Dsgn. L = 30.00 ft		2	0.269	0.088	89.79	-87.81	89.79	558.33	334.33	1.00	1.00	14.73	279.66	167.46
+D+0.70S														
Dsgn. L = 12.00 ft		1	0.244	0.097	0.72	-81.49	81.49	558.33	334.33	1.00	1.00	16.22	279.66	167.46
Dsgn. L = 30.00 ft		2	0.251	0.082	83.77	-81.49	83.77	558.33	334.33	1.00	1.00	13.71	279.66	167.46
+D+0.750Lr+0.750L														
Dsgn. L = 12.00 ft		1	0.524	0.199	6.44	-175.08	175.08	558.33	334.33	1.00	1.00	33.34	279.66	167.46
Dsgn. L = 30.00 ft		2	0.543	0.176	181.39	-175.08	181.39	558.33	334.33	1.00	1.00	29.40	279.66	167.46

Project Title:
 Engineer:
 Project ID:
 Project Descr:

Steel Beam

Project File:

LIC# : KW-06019737, Build:20.25.10.02

PLIRIS

(c) ENERCALC, LLC 1982-2025

DESCRIPTION: 2ND FLOOR - BEAM OVER GARAGE

Maximum Forces & Stresses for Load Combinations

Load Combination	Segment Length	Span #	Max Stress Ratios		Summary of Moment Values					Summary of Shear Values				
			M	V	Mmax +	Mmax -	Ma Max	Mnx	Mnx/Omega Cb	Rm	Va Max	VnxVnx/Omega		
+D+0.750L+0.5250S														
Dsgn. L = 12.00 ft		1	0.510	0.190	7.84	-170.35	170.35	558.33	334.33	1.00	1.00	31.87	279.66	167.46
Dsgn. L = 30.00 ft		2	0.529	0.171	176.88	-170.35	176.88	558.33	334.33	1.00	1.00	28.63	279.66	167.46
+0.60D														
Dsgn. L = 12.00 ft		1	0.131	0.049	1.45	-43.84	43.84	558.33	334.33	1.00	1.00	8.17	279.66	167.46
Dsgn. L = 30.00 ft		2	0.136	0.044	45.45	-43.84	45.45	558.33	334.33	1.00	1.00	7.41	279.66	167.46
+D+0.750L+0.10S														
Dsgn. L = 12.00 ft		1	0.494	0.181	9.51	-165.23	165.23	558.33	334.33	1.00	1.00	30.29	279.66	167.46
Dsgn. L = 30.00 ft		2	0.514	0.166	172.01	-165.23	172.01	558.33	334.33	1.00	1.00	27.81	279.66	167.46

Overall Maximum Deflections

Span	Load Combination	Max. "-" Defl	Location in Span	Load Combination	Max. "+" Defl	Location in Span
1		0.0000	0.000	+D+L	-0.0348	8.352
2	+D+L	0.5947	16.800		0.0000	8.352

Vertical Reactions

Support notation : Far left is #

Values in KIPS

Load Combination	Support 1	Support 2	Support 3
Max Upward from all Load Conditions	5.117	68.046	22.571
Max Upward from Load Combinations	5.117	68.046	22.571
Max Upward from Load Cases	3.754	42.079	14.167
Max Downward from all Load Conditions (Resisting Uplift)	-1.083		
Max Downward from Load Cases (Resisting Uplift)	-1.083		
D Only	1.363	25.968	8.404
+D+L	5.117	68.046	22.571
+D+Lr	0.280	32.907	9.508
+D+0.70S	0.744	29.932	9.035
+D+0.750Lr+0.750L	3.366	62.731	19.857
+D+0.750L+0.5250S	3.715	60.500	19.502
+0.60D	0.818	15.581	5.042
+D+0.750L+0.10S	4.090	58.093	19.120
Lr Only	-1.083	6.939	1.104
L Only	3.754	42.079	14.167
S Only	-0.884	5.663	0.901

Connection Shear Capacity (Nail and Bolt)

Shear Planes:	2	(1 or 2)		
Diameter, D:	1	in.		
Gm:	0.5	%	[Tab. 11.3.2A]	
Gs:	0.5	%	[Tab. 11.3.2A]	Re: 1.0000
Fem:	60000	psi	[Tab. 11.3.2]	Rt: 0.7500
Fes:	60000	psi	[Tab. 11.3.2]	
tm (lm):	0.375	in.		k1: 0.3687
ts (ls):	0.5	in.		k2: 2.8297
Fyb:	45000	psi		k3: 2.1623

Kd=		
Θ=	0	degrees [Tab 11.3.1B]
KΘ=	1.00	
Rd:	I=	4.00
	II=	3.60
	III=	3.20
	IV=	3.20

<u>Yield</u>	<u>Single Shear</u>		<u>Double Shear</u>	
Mode Im	Z=	lbf	Z=	5625.0 lbf
Mode Is	Z=	lbf	Z=	15000.0 lbf
Mode II	Z=	lbf		
Mode IIIm	Z=	lbf		
Mode IIIs	Z=	lbf	Z=	13514.2 lbf
Mode IV	Z=	lbf	Z=	18750.0 lbf

Governs

Max Allowable: 0.00

Max Allowable: 5625.0

Z= 5625 lbf

of fasteners in row, n: 2

Cd:	1	[Tab 2.3.2]
Cm:	1	[Tab 10.3.3]
Ct:	1	[Tab 10.3.4]
Cg:	1	
CΔ:	1	[Tab 11.5.1B]
Ceg:	1	
Cdi:	1	
Ctn:	1	

Em:	1600000	psi
Es:	1600000	psi
Am:	12.25	in ²
As:	12.25	in ²
o.c. spacing of fastners, s:	12	in [Tab 11.5.1C]
γ:	220992	lbs./in [10.3.6]
u=	1.135301	
m=	0.597799	
REA=	1	

Z'= 5625 lbf / bolt

Project Title:
 Engineer:
 Project ID:
 Project Descr:

Steel Column

Project File:

LIC# : KW-06019737, Build:20.25.10.02

PLIRIS

(c) ENERCALC, LLC 1982-2025

DESCRIPTION: 70K COLUMN IN STORAGE AND BACK OF COMMERCIAL

Maximum Reactions

Note: Only non-zero reactions are listed.

Load Combination	Axial (k)	Rx (k)		Ry (k)		Mx (k-ft)		My (k-ft)	
	@ Base	@ Base	@ Top	@ Base	@ Top	@ Base	@ Top	@ Base	@ Top
+0.60D	15.674								
+D+0.750L+0.10S	58.249								
Lr Only	6.939								
L Only	42.079								
S Only	5.663								

Extreme Reactions

Item	Extreme Value	Axial (k)	Rx (k)		Ry (k)		Mx (k-ft)		My (k-ft)	
		@ Base	@ Base	@ Top	@ Base	@ Top	@ Base	@ Top	@ Base	@ Top
Axial, Base Max		68.203								
Axial, Base Min		5.663								
Rx, Base Max										
Rx, Base Min										
Rx, Top Max										
Rx, Top Min										
Ry, Base Max										
Ry, Base Min										
Ry, Top Max										
Ry, Top Min										
Mx, Base Max										
Mx, Base Min										
Mx, Top Max										
Mx, Top Min										
My, Base Max										
My, Base Min										
My, Top Max										
My, Top Min										

Maximum Deflections for Load Combinations

Load Combination	Max. Deflection in X dir	Distance	Max. Deflection in Y dir	Distance
D Only	0.0000 in	0.000 ft	0.000 in	0.000 ft
+D+L	0.0000 in	0.000 ft	0.000 in	0.000 ft
+D+Lr	0.0000 in	0.000 ft	0.000 in	0.000 ft
+D+0.70S	0.0000 in	0.000 ft	0.000 in	0.000 ft
+D+0.750Lr+0.750L	0.0000 in	0.000 ft	0.000 in	0.000 ft
+D+0.750L+0.5250S	0.0000 in	0.000 ft	0.000 in	0.000 ft
+0.60D	0.0000 in	0.000 ft	0.000 in	0.000 ft
+D+0.750L+0.10S	0.0000 in	0.000 ft	0.000 in	0.000 ft
Lr Only	0.0000 in	0.000 ft	0.000 in	0.000 ft
L Only	0.0000 in	0.000 ft	0.000 in	0.000 ft
S Only	0.0000 in	0.000 ft	0.000 in	0.000 ft

Steel Section Properties : HSS6x4x1/4

Depth	=	6.000 in	I xx	=	20.90 in^4	J	=	23.600 in^4
Design Thick	=	0.233 in	S xx	=	6.96 in^3	Cw	=	10.10 in^6
Width	=	4.000 in	R xx	=	2.200 in			
Wall Thick	=	0.250 in	Zx	=	8.530 in^3			
Area	=	4.300 in^2	I yy	=	11.100 in^4	C	=	10.100 in^3
Weight	=	15.620 plf	S yy	=	5.560 in^3			
			R yy	=	1.610 in			
			Zy	=	6.450 in^3			
Ycg	=	0.000 in						

Steel Column

Project File:

LIC# : KW-06019737, Build:20.25.10.02

PLIRIS

(c) ENERCALC, LLC 1982-2025

DESCRIPTION: 70K COLUMN IN STORAGE AND BACK OF COMMERCIAL

Sketches

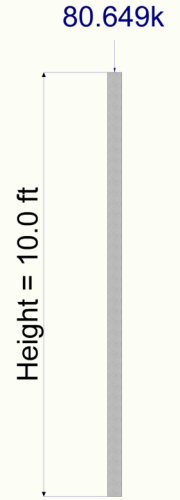
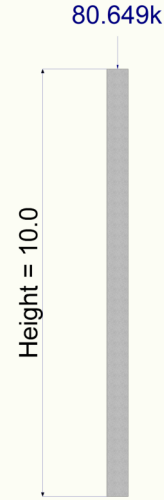
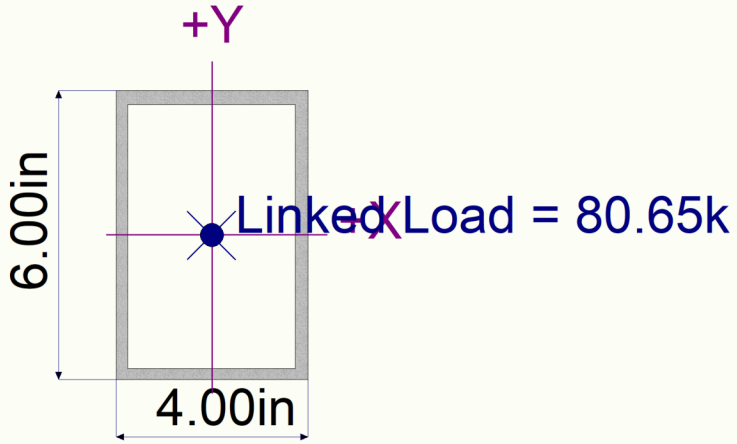

Project Title:
 Engineer:
 Project ID:
 Project Descr:

Concrete Column

Project File:

LIC# : KW-06019737, Build:20.25.10.02

PLIRIS

(c) ENERCALC, LLC 1982-2025

DESCRIPTION: GARAGE ENTRY

Code References

Governing Code : IBC 2021
 Referenced Design Standard(s) : ACI 318-19
 Load Combinations Used : ASCE 7-22 / IBC 2024

General Information

f'_c : Concrete 28 day strength =	3.0 ksi	Overall Column Height =	10.0 ft
E =	3,122.0 ksi	End Fixity	Top Pinned, Bottom Fixed
Density =	150.0 pcf	Brace condition for deflection (buckling) along column	
β =	0.850	X-X (width) axis :	
f_y - Main Rebar =	60.0 ksi		Fully braced against buckling ABOUT Y-Y Axis
E - Main Rebar =	29,000.0 ksi	Y-Y (depth) axis :	
Allow. Reinforcing Limits	ASTM A615 Bars Used		Fully braced against buckling ABOUT Y-Y Axis
Min. Reinf. =	1.0 %		
Max. Reinf. =	8.0 %		
Seismic Design Category =	C		

Column Cross Section

Column Dimensions : 24.0in high x 14.0in Wide, Column
 Edge to Rebar Edge Cover = 2.0in

Column Reinforcing : general

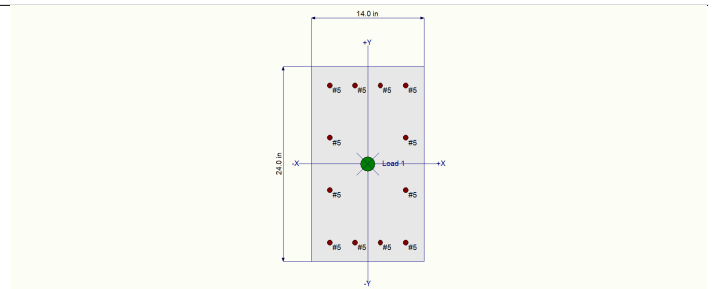

Rebar Sizes & Locations

Total bars = 12

X & Y distances measured from lower-left corner.

Bar Size #	X in	Y in	Bar Size #	X in	Y in	Bar Size #	X in	Y in	Bar Size #	X in	Y in
# 5	2.313	2.313	# 5	2.313	21.688	# 5	11.688	21.688	# 5	11.688	2.313
# 5	5.438	21.688	# 5	5.438	2.313	# 5	8.563	21.688	# 5	8.563	2.313
# 5	2.313	8.771	# 5	11.688	8.771	# 5	2.313	15.229	# 5	11.688	15.229

Applied Loads

Entered loads are factored per load combinations specified by user.

Column self weight included : 3,500.0 lbs * Dead Load Factor

AXIAL LOADS . . .

Axial Load at 10.0 ft above base, D = 13.059, LR = 0.6570, L = 10.762, S = 0.5360 k

BENDING LOADS . . .

Lat. Point Load at 10.0 ft creating Mx-x, W = 4.750, E = 3.40 k

Project Title:
 Engineer:
 Project ID:
 Project Descr:

Concrete Column

Project File:

LIC# : KW-06019737, Build:20.25.10.02

PLIRIS

(c) ENERCALC, LLC 1982-2025

DESCRIPTION: GARAGE ENTRY

DESIGN SUMMARY

Load Combination	+1.20D+0.50Lr+1.60L		Maximum SERVICE Load Reactions .			
Location of max.above base	9.933 ft		Top along Y-Y	0.0 k	Bottom along Y-Y	0.0 k
Maximum Stress Ratio	0.068 : 1		Top along X-X	4.750 k	Bottom along X-X	0.0 k
Ratio = (Pu ² +Mu ²) ^{0.5} / (PhiPn ² +PhiMn ²) ^{0.5}			Maximum SERVICE Load Deflections . .			
Pu = 37.419 k	φ * Pn =	556.67 k	Along Y-Y	0.0 in at	0.0 ft above base	
Mu-x = 4.116 k-ft	φ * Mn-x =	58.840 k-ft	for load combination :			
Mu-y = 0.0 k-ft	φ * Mn-y =	0.0 k-ft	Along X-X	0.0 in at	0.0 ft above base	
Mu Angle = 0.0 deg	φ =	0.650	for load combination :			
Mu at Angle = 4.116 k-ft	φMn at Angle =	60.233 k-ft				
<i>Pn & Mn values located at Pu-Mu vector intersection with capacity curve</i>						
Column Capacities . .			General Section Information			
Pnmax : Nominal Max. Compressive Axial Capacity	1,070.51 k		ρ : % Reinforcing	1.107 %	Rebar % Ok	
Pnmin : Nominal Min. Tension Axial Capacity	k		Reinforcing Area	3.720 in ²		
φ Pn, max : Usable Compressive Axial Capacity	556.67 k		Concrete Area	336.0 in ²		
φ Pn, min : Usable Tension Axial Capacity	k					
					β = 0.850	θ = 0.80

Governing Load Combination Results

Governing Factored Load Combination	Moment		Dist. from base ft	Axial Load k		Bending Analysis k-ft						Utilization Ratio	
	X-X	Y-Y		Pu	φ * Pn	δx	δx * Mux	δy	δy * Muy	Alpha (deg)	δ Mu	φ Mn	Ratio
+1.40D	Actual	M2,min	9.93	23.18	556.67	1.000		1.000	1.97	90.000	1.97	47.43	0.042
+1.40D	M2,min	Actual	9.93	23.18	556.67	1.000	2.55	1.000		0.000	2.55	60.23	0.042
+1.20D+0.50Lr+1.60L	Actual	M2,min	9.93	37.42	556.67	1.000		1.000	3.18	90.000	3.18	47.43	0.067
+1.20D+0.50Lr+1.60L	M2,min	Actual	9.93	37.42	556.67	1.000	4.12	1.000		0.000	4.12	60.23	0.068
+1.20D+1.60L+0.30S	Actual	M2,min	9.93	37.25	556.67	1.000		1.000	3.17	90.000	3.17	47.43	0.067
+1.20D+1.60L+0.30S	M2,min	Actual	9.93	37.25	556.67	1.000	4.10	1.000		0.000	4.10	60.23	0.068
+1.20D+1.60Lr+L	Actual	M2,min	9.93	31.68	556.67	1.000		1.000	2.69	90.000	2.69	47.43	0.057
+1.20D+1.60Lr+L	M2,min	Actual	9.93	31.68	556.67	1.000	3.49	1.000		0.000	3.49	60.23	0.058
+1.20D+1.60Lr+0.50W	Actual	M2,min	9.93	20.92	556.67	1.000	-0.00	1.000	1.78	90.000	1.78	47.43	0.038
+1.20D+1.60Lr+0.50W	M2,min	Actual	9.93	20.92	556.67	1.000	2.30	1.000		0.000	2.30	60.23	0.038
+1.20D+L+S	Actual	M2,min	9.93	31.17	556.67	1.000		1.000	2.65	90.000	2.65	47.43	0.056
+1.20D+L+S	M2,min	Actual	9.93	31.17	556.67	1.000	3.43	1.000		0.000	3.43	60.23	0.057
+1.20D+S+0.50W	Actual	M2,min	9.93	20.41	556.67	1.000	-0.00	1.000	1.73	90.000	1.73	47.43	0.037
+1.20D+S+0.50W	M2,min	Actual	9.93	20.41	556.67	1.000	2.24	1.000		0.000	2.24	60.23	0.037
+1.20D+0.50Lr+L+W	Actual	M2,min	9.93	30.96	556.67	1.000	-0.00	1.000	2.63	90.000	2.63	47.43	0.056
+1.20D+0.50Lr+L+W	M2,min	Actual	9.93	30.96	556.67	1.000	3.41	1.000		0.000	3.41	60.23	0.056
+1.20D+L+0.30S+W	Actual	M2,min	9.93	30.79	556.67	1.000	-0.00	1.000	2.62	90.000	2.62	47.43	0.055
+1.20D+L+0.30S+W	M2,min	Actual	9.93	30.79	556.67	1.000	3.39	1.000		0.000	3.39	60.23	0.056
+0.90D+W	Actual	M2,min	9.93	14.90	556.67	1.000	-0.00	1.000	1.27	90.000	1.27	47.43	0.027
+0.90D+W	M2,min	Actual	9.93	14.90	556.67	1.000	1.64	1.000		0.000	1.64	60.23	0.027
+1.20D+L+0.150S+E	Actual	M2,min	9.93	30.71	556.67	1.000	-0.00	1.000	2.61	90.000	2.61	47.43	0.055
+1.20D+L+0.150S+E	M2,min	Actual	9.93	30.71	556.67	1.000	3.38	1.000		0.000	3.38	60.23	0.056
+0.90D+E	Actual	M2,min	9.93	14.90	556.67	1.000	-0.00	1.000	1.27	90.000	1.27	47.43	0.027
+0.90D+E	M2,min	Actual	9.93	14.90	556.67	1.000	1.64	1.000		0.000	1.64	60.23	0.027

Maximum Reactions

Note: Only non-zero reactions are listed.

Load Combination	X-X Axis Reaction k		Y-Y Axis Reaction k		Axial Reaction @ Base	Mx - End Moments k-ft		My - End Moments k-ft	
	@ Base	@ Top	@ Base	@ Top		@ Base	@ Top	@ Base	@ Top
D Only					16.559				
+D+L					27.321				
+D+Lr					17.216				
+D+0.70S					16.934				
+D+0.750Lr+0.750L					25.123				
+D+0.750L+0.5250S					24.912				
+D+0.60W				2.850	16.559		-0.000		

Project Title:
 Engineer:
 Project ID:
 Project Descr:

Concrete Column

Project File:

LIC# : KW-06019737, Build:20.25.10.02

PLIRIS

(c) ENERCALC, LLC 1982-2025

DESCRIPTION: GARAGE ENTRY

Maximum Reactions

Note: Only non-zero reactions are listed.

Load Combination	X-X Axis Reaction		k	Y-Y Axis Reaction		Axial Reaction	Mx - End Moments		k-ft	My - End Moments	
	@ Base	@ Top		@ Base	@ Top		@ Base	@ Base		@ Top	@ Base
+D+0.750Lr+0.750L+0.450W				2.137		25.123	-0.000				
+D+0.750L+0.5250S+0.450W				2.137		24.912	-0.000				
+0.60D+0.60W				2.850		9.935	-0.000				
+D+0.70E				2.380		16.559	-0.000				
+D+0.750L+0.10S+0.5250E				1.785		24.684	-0.000				
+0.60D+0.70E				2.380		9.935	-0.000				
Lr Only						0.657					
L Only						10.762					
S Only						0.536					
W Only				4.750			-0.000				
E Only				3.400			-0.000				

Maximum Moment Reactions

Note: Only non-zero reactions are listed.

Load Combination	Moment About X-X Axis			Moment About Y-Y Axis	
	@ Base	@ Top		@ Base	@ Top
D Only			k-ft		k-ft
+D+L			k-ft		k-ft
+D+Lr			k-ft		k-ft
+D+0.70S			k-ft		k-ft
+D+0.750Lr+0.750L			k-ft		k-ft
+D+0.750L+0.5250S			k-ft		k-ft
+D+0.60W	-0.000		k-ft		k-ft
+D+0.750Lr+0.750L+0.450W	-0.000		k-ft		k-ft
+D+0.750L+0.5250S+0.450W	-0.000		k-ft		k-ft
+0.60D+0.60W	-0.000		k-ft		k-ft
+D+0.70E	-0.000		k-ft		k-ft
+D+0.750L+0.10S+0.5250E	-0.000		k-ft		k-ft
+0.60D+0.70E	-0.000		k-ft		k-ft
Lr Only			k-ft		k-ft
L Only			k-ft		k-ft
S Only			k-ft		k-ft
W Only	-0.000		k-ft		k-ft
E Only	-0.000		k-ft		k-ft

Maximum Deflections for Load Combinations

Load Combination	Max. X-X Deflection		Distance	Max. Y-Y Deflection		Distance		
D Only	0.0000	in	0.000	ft	0.000	in	0.000	ft
+D+L	0.0000	in	0.000	ft	0.000	in	0.000	ft
+D+Lr	0.0000	in	0.000	ft	0.000	in	0.000	ft
+D+0.70S	0.0000	in	0.000	ft	0.000	in	0.000	ft
+D+0.750Lr+0.750L	0.0000	in	0.000	ft	0.000	in	0.000	ft
+D+0.750L+0.5250S	0.0000	in	0.000	ft	0.000	in	0.000	ft
+D+0.60W	0.0000	in	0.000	ft	0.000	in	0.000	ft
+D+0.750Lr+0.750L+0.450W	0.0000	in	0.000	ft	0.000	in	0.000	ft
+D+0.750L+0.5250S+0.450W	0.0000	in	0.000	ft	0.000	in	0.000	ft
+0.60D+0.60W	0.0000	in	0.000	ft	0.000	in	0.000	ft
+D+0.70E	0.0000	in	0.000	ft	0.000	in	0.000	ft
+D+0.750L+0.10S+0.5250E	0.0000	in	0.000	ft	0.000	in	0.000	ft
+0.60D+0.70E	0.0000	in	0.000	ft	0.000	in	0.000	ft
Lr Only	0.0000	in	0.000	ft	0.000	in	0.000	ft
L Only	0.0000	in	0.000	ft	0.000	in	0.000	ft
S Only	0.0000	in	0.000	ft	0.000	in	0.000	ft
W Only	0.0000	in	0.000	ft	0.000	in	0.000	ft
E Only	0.0000	in	0.000	ft	0.000	in	0.000	ft

Project Title:
Engineer:
Project ID:
Project Descr:

Concrete Column

Project File:

LIC# : KW-06019737, Build:20.25.10.02

PLIRIS

(c) ENERCALC, LLC 1982-2025

DESCRIPTION: GARAGE ENTRY

Sketches

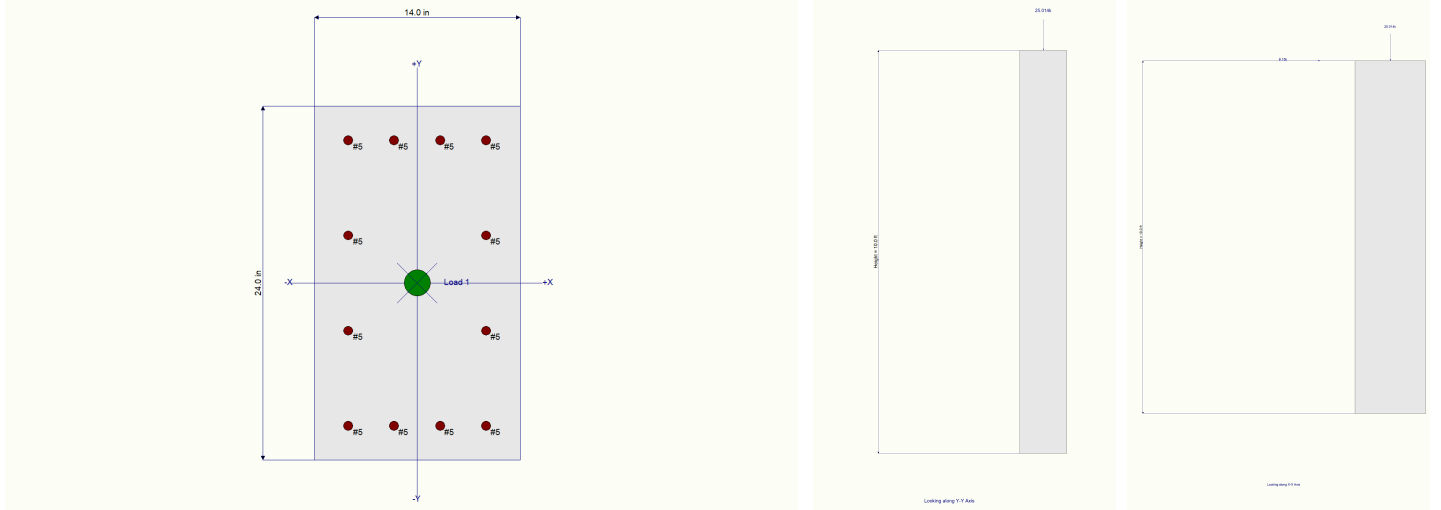

Interaction Diagrams

Project Title:
Engineer:
Project ID:
Project Descr:

Concrete Column

Project File:

LIC# : KW-06019737, Build:20.25.10.02

PLIRIS

(c) ENERCALC, LLC 1982-2025

DESCRIPTION: GARAGE ENTRY

Concrete Column P-M Interaction Diagram

Phi * Mn @ Alpha (k-ft)

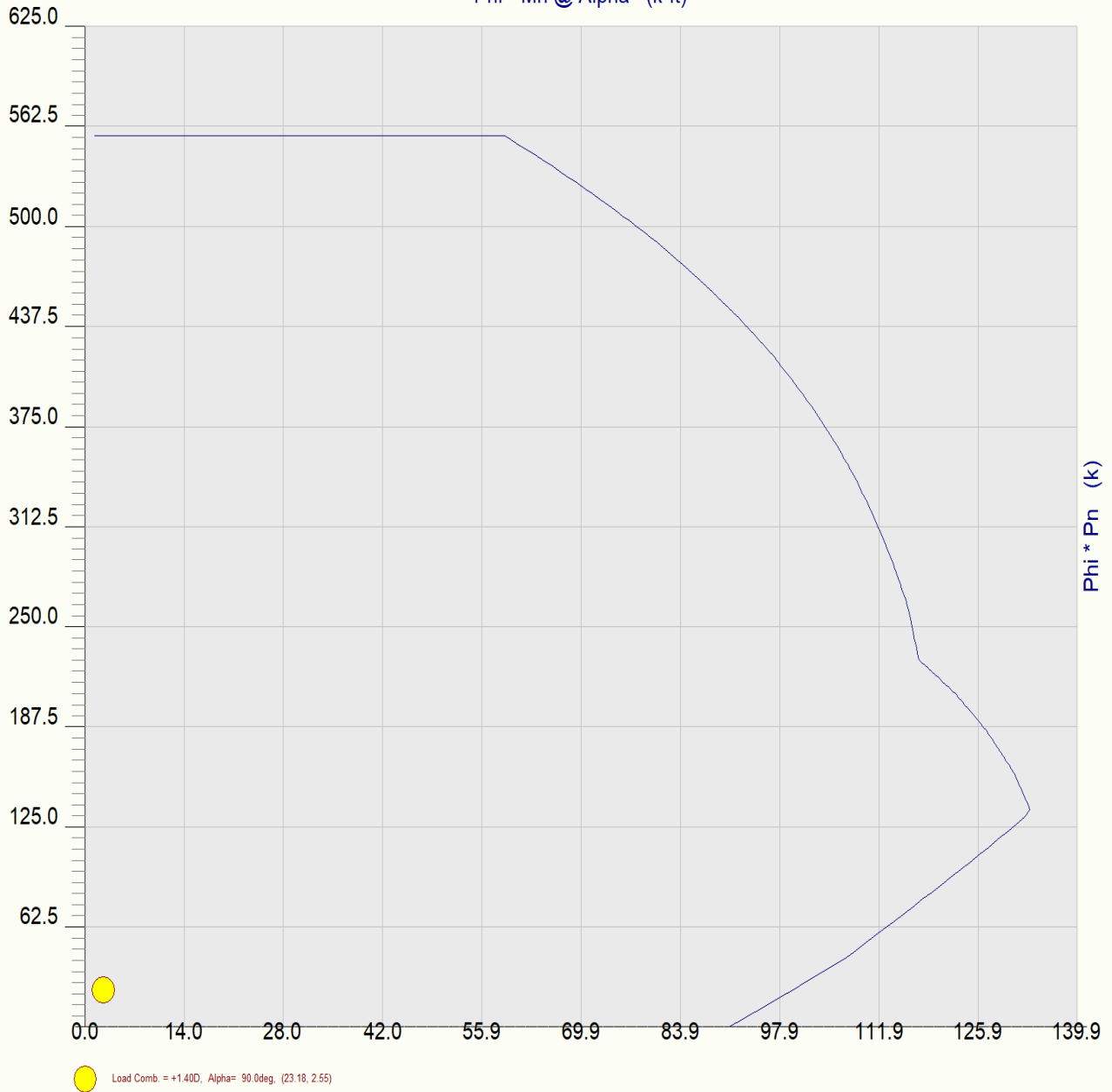

Project Title:
Engineer:
Project ID:
Project Descr:

Concrete Column

Project File:

LIC# : KW-06019737, Build:20.25.10.02

PLIRIS

(c) ENERCALC, LLC 1982-2025

DESCRIPTION: GARAGE ENTRY

Concrete Column P-M Interaction Diagram

Phi * Mn @ Alpha (k-ft)

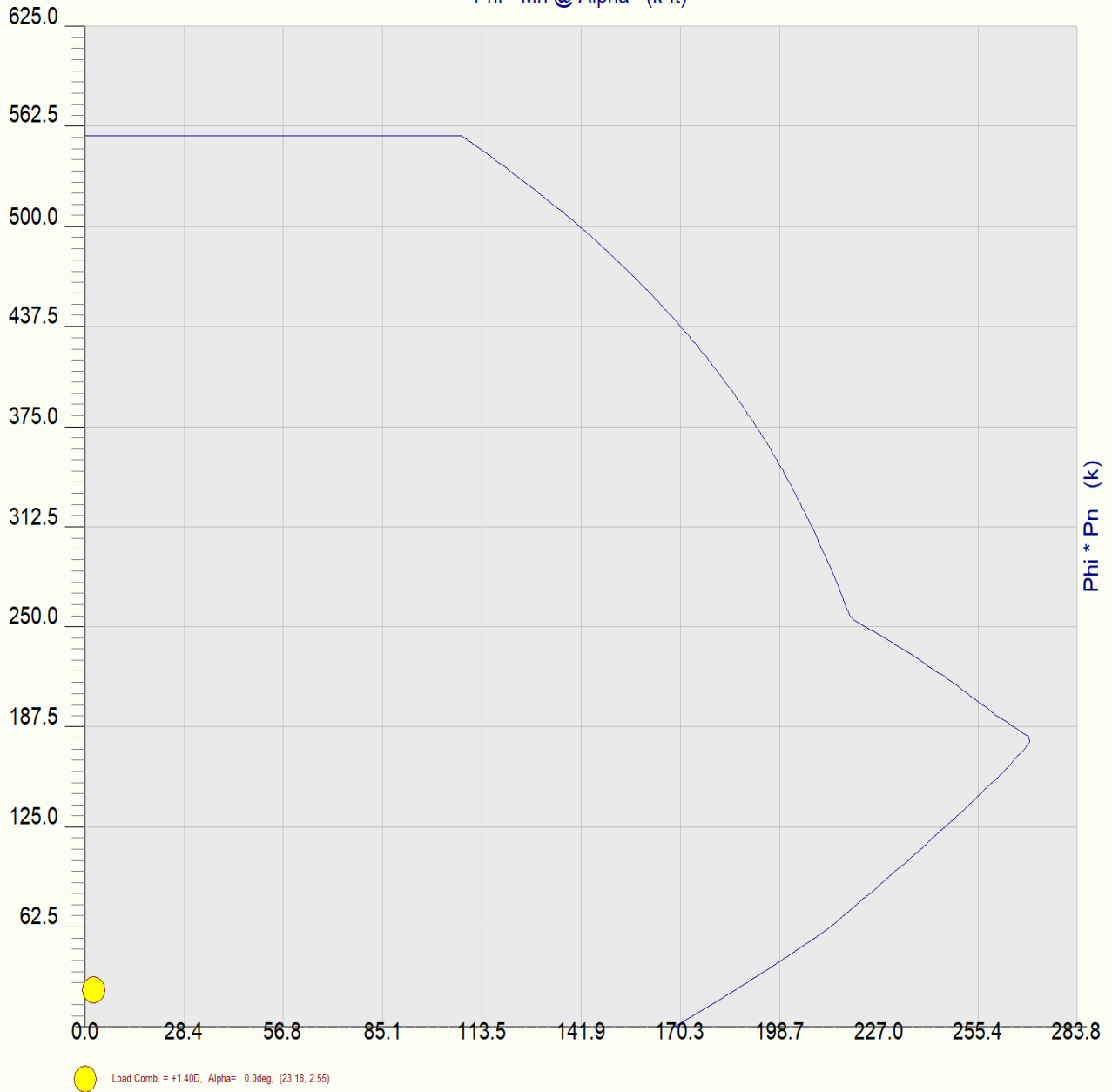

Project Title:
Engineer:
Project ID:
Project Descr:

Concrete Column

Project File:

LIC# : KW-06019737, Build:20.25.10.02

PLIRIS

(c) ENERCALC, LLC 1982-2025

DESCRIPTION: GARAGE ENTRY

Concrete Column P-M Interaction Diagram

Phi * Mn @ Alpha (k-ft)



Project Title:
Engineer:
Project ID:
Project Descr:

Concrete Column

Project File:

LIC# : KW-06019737, Build:20.25.10.02

PLIRIS

(c) ENERCALC, LLC 1982-2025

DESCRIPTION: GARAGE ENTRY

Concrete Column P-M Interaction Diagram

Phi * Mn @ Alpha (k-ft)



Project Title:
Engineer:
Project ID:
Project Descr:

Concrete Column

Project File:

LIC# : KW-06019737, Build:20.25.10.02

PLIRIS

(c) ENERCALC, LLC 1982-2025

DESCRIPTION: GARAGE ENTRY

Concrete Column P-M Interaction Diagram

Phi * Mn @ Alpha (k-ft)



Project Title:
Engineer:
Project ID:
Project Descr:

Concrete Column

Project File:

LIC# : KW-06019737, Build:20.25.10.02

PLIRIS

(c) ENERCALC, LLC 1982-2025

DESCRIPTION: GARAGE ENTRY

Concrete Column P-M Interaction Diagram

Phi * Mn @ Alpha (k-ft)



Project Title:
Engineer:
Project ID:
Project Descr:

Concrete Column

Project File:

LIC# : KW-06019737, Build:20.25.10.02

PLIRIS

(c) ENERCALC, LLC 1982-2025

DESCRIPTION: GARAGE ENTRY

Concrete Column P-M Interaction Diagram

Phi * Mn @ Alpha (k-ft)

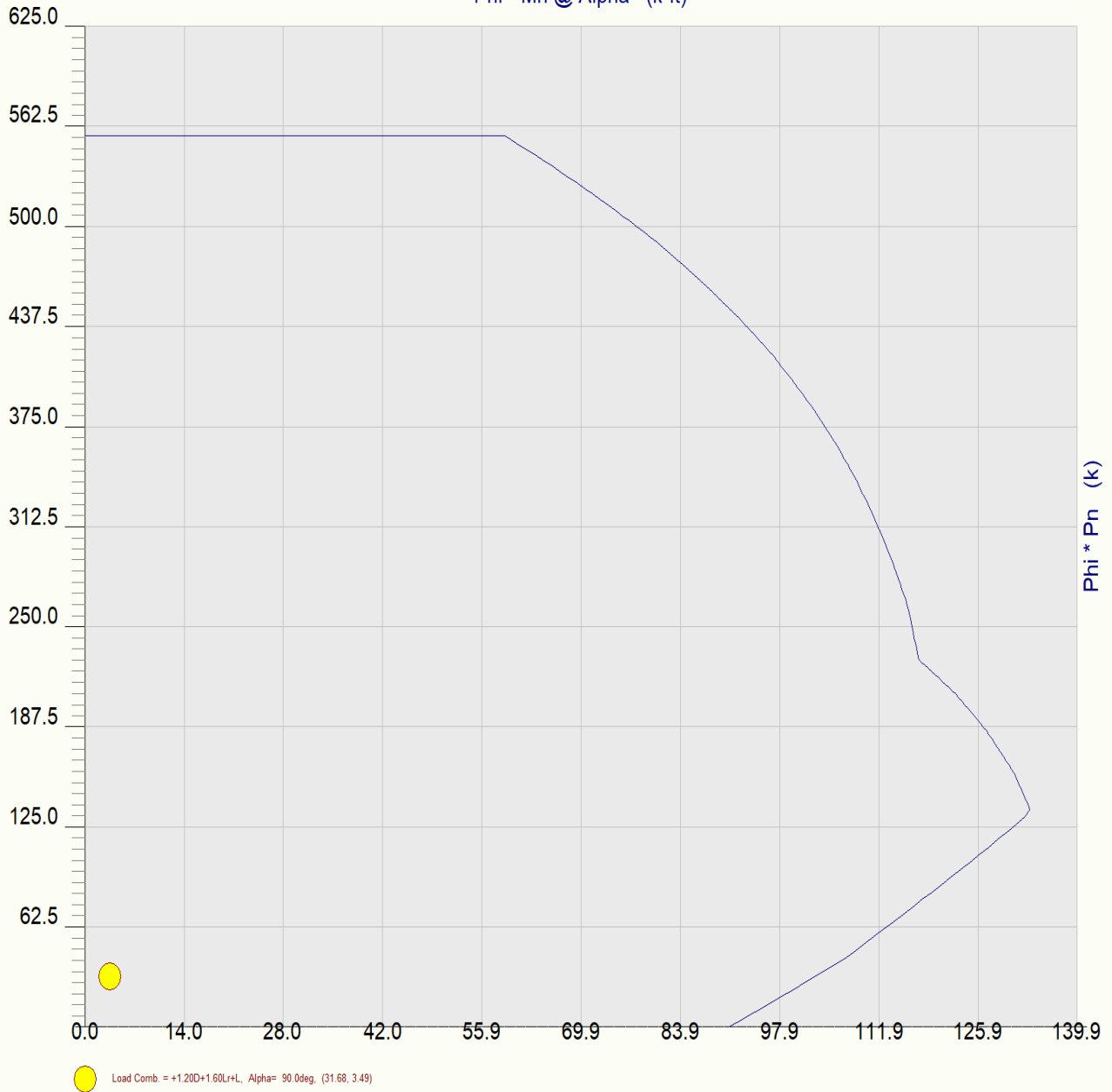

Concrete Column

Project File:

LIC# : KW-06019737, Build:20.25.10.02

PLIRIS

(c) ENERCALC, LLC 1982-2025

DESCRIPTION: GARAGE ENTRY

Concrete Column P-M Interaction Diagram

Phi * Mn @ Alpha (k-ft)



Project Title:
Engineer:
Project ID:
Project Descr:

Concrete Column

Project File:

LIC# : KW-06019737, Build:20.25.10.02

PLIRIS

(c) ENERCALC, LLC 1982-2025

DESCRIPTION: GARAGE ENTRY

Concrete Column P-M Interaction Diagram



Project Title:
Engineer:
Project ID:
Project Descr:

Concrete Column

Project File:

LIC# : KW-06019737, Build:20.25.10.02

PLIRIS

(c) ENERCALC, LLC 1982-2025

DESCRIPTION: GARAGE ENTRY

Concrete Column P-M Interaction Diagram

Phi * Mn @ Alpha (k-ft)



Project Title:
Engineer:
Project ID:
Project Descr:

Concrete Column

Project File:

LIC# : KW-06019737, Build:20.25.10.02

PLIRIS

(c) ENERCALC, LLC 1982-2025

DESCRIPTION: GARAGE ENTRY

Concrete Column P-M Interaction Diagram

Phi * Mn @ Alpha (k-ft)



Project Title:
Engineer:
Project ID:
Project Descr:

Concrete Column

Project File:

LIC# : KW-06019737, Build:20.25.10.02

PLIRIS

(c) ENERCALC, LLC 1982-2025

DESCRIPTION: GARAGE ENTRY

Concrete Column P-M Interaction Diagram

Phi * Mn @ Alpha (k-ft)



Project Title:
Engineer:
Project ID:
Project Descr:

Concrete Column

Project File:

LIC# : KW-06019737, Build:20.25.10.02

PLIRIS

(c) ENERCALC, LLC 1982-2025

DESCRIPTION: GARAGE ENTRY

Concrete Column P-M Interaction Diagram

Phi * Mn @ Alpha (k-ft)



Project Title:
Engineer:
Project ID:
Project Descr:

Concrete Column

Project File:

LIC# : KW-06019737, Build:20.25.10.02

PLIRIS

(c) ENERCALC, LLC 1982-2025

DESCRIPTION: GARAGE ENTRY

Concrete Column P-M Interaction Diagram

Phi * Mn @ Alpha (k-ft)



Project Title:
Engineer:
Project ID:
Project Descr:

Concrete Column

Project File:

LIC# : KW-06019737, Build:20.25.10.02

PLIRIS

(c) ENERCALC, LLC 1982-2025

DESCRIPTION: GARAGE ENTRY

Concrete Column P-M Interaction Diagram

Phi * Mn @ Alpha (k-ft)



Project Title:
Engineer:
Project ID:
Project Descr:

Concrete Column

Project File:

LIC# : KW-06019737, Build:20.25.10.02

PLIRIS

(c) ENERCALC, LLC 1982-2025

DESCRIPTION: GARAGE ENTRY

Concrete Column P-M Interaction Diagram

Phi * Mn @ Alpha (k-ft)



Project Title:
 Engineer:
 Project ID:
 Project Descr:

General Footing

Project File:

LIC# : KW-06019737, Build:20.25.10.02

PLIRIS

(c) ENERCALC, LLC 1982-2025

DESCRIPTION: GARAGE COLUMN FOOTING

Code References

Governing Code : IBC 2021
 Referenced Design Standard(s) : ACI 318-19
 Load Combinations Used : ASCE 7-22 / IBC 2024

General Information

Material Properties

f'_c : Concrete 28 day strength	=	3.0 ksi
f_y : Rebar Yield	=	60.0 ksi
E_c : Concrete Elastic Modulus	=	3,122.0 ksi
Concrete Density	=	145.0 pcf
ϕ Values Flexure	=	0.90
Shear	=	0.750

Analysis Settings

Min Steel % Bending Reinf.	=	
Min Allow % Temp Reinf.	=	
Min. Overturning Safety Factor	=	1.0 : 1
Min. Sliding Safety Factor	=	1.0 : 1
Add Ftg Wt for Soil Pressure	:	Yes
Use ftg wt for stability, moments & shears	:	Yes
Add Pedestal Wt for Soil Pressure	:	Yes
Use Pedestal wt for stability, mom & shear	:	Yes

Soil Design Values

Allowable Soil Bearing	=	1.50 ksf
Soil Density	=	110.0 pcf
Increase Bearing By Footing Weight	=	No
Soil Passive Resistance (for Sliding)	=	250.0 pcf
Soil/Concrete Friction Coeff.	=	0.30

Increases based on footing Depth

Footing base depth below soil surface	=	ft
Allow press. increase per foot of depth when footing base is below	=	ksf ft

Increases based on footing plan dimension

Allowable pressure increase per foot of depth when max. length or width is greater than	=	ksf ft
---	---	-----------

Dimensions

Width parallel to X-X Axis	=	5.0 ft
Length parallel to Z-Z Axis	=	7.50 ft
Footing Thickness	=	12.0 in

Pedestal dimensions...

p_x : parallel to X-X Axis	=	24.0 in
p_z : parallel to Z-Z Axis	=	14.0 in
Height	=	12.0 in

Bandwidth Distribution Check (ACI 15.4.4.2)

Direction Requiring Closer Separation Bars along X-X Axis	
# Bars required within zone	80.0 %
# Bars required on each side of zone	20.0 %

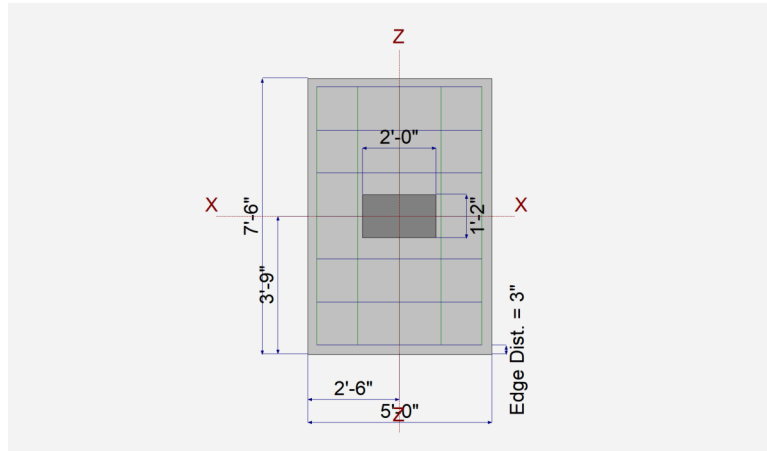

Bottom Reinforcing

Bars parallel to X-X Axis (resisting Z Flexure)		
Number of Bars	=	7
Reinforcing Bar Size	=	# 5
Bars parallel to Z-Z Axis (resisting X Flexure)		
Number of Bars	=	5
Reinforcing Bar Size	=	# 5
Rebar Centerline to Edge of Concrete... at Bottom of footing	=	3.0 in

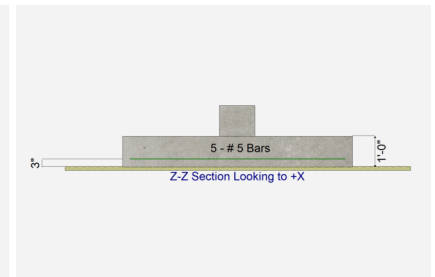
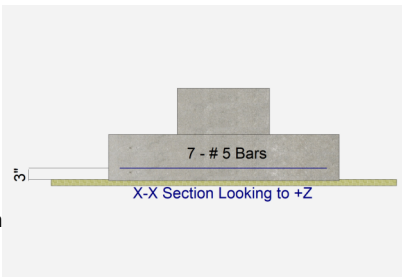

Top Reinforcing

Bars parallel to X-X Axis (resisting Z Flexure)		
Number of Bars	=	7
Reinforcing Bar Size	=	5
Bars parallel to Z-Z Axis (resisting X Flexure)		
Number of Bars	=	5
Reinforcing Bar Size	=	5
Rebar Centerline to Edge of Concrete... at Top of footing	=	3.0 in

Project Title:
 Engineer:
 Project ID:
 Project Descr:

General Footing

Project File:

LIC# : KW-06019737, Build:20.25.10.02

PLIRIS

(c) ENERCALC, LLC 1982-2025

DESCRIPTION: GARAGE COLUMN FOOTING

Applied Loads

	D	Lr	L	S	W	E	H
P : Column Load	= 16.560	0.660	10.760	0.5360			k
OB : Overburden	=						ksf
M-xx	=				47.50	34.0	k-ft
M-zz	=						k-ft
V-x	=						k
V-z	=						k

DESIGN SUMMARY

Design OK

	Min. Ratio	Item	Applied	Capacity	Governing Load Combination
PASS	0.850	Soil Bearing	1.275 ksf	1.50 ksf	+D+0.750Lr+0.750L+0.450W about X-
PASS	1.763	Overturning - X-X	28.50 k-ft	50.256 k-ft	+0.60D+0.60W
PASS	n/a	Overturning - Z-Z	0.0 k-ft	0.0 k-ft	No Overturning
PASS	n/a	Sliding - X-X	0.0 k	0.0 k	No Sliding
PASS	n/a	Sliding - Z-Z	0.0 k	0.0 k	No Sliding
PASS	n/a	Uplift	0.0 k	0.0 k	No Uplift
PASS	0.09999	Z Flexure (+X) Bot Tens	1.135 k-ft/ft	11.349 k-ft/ft	+1.20D+0.50Lr+1.60L
PASS	0.09999	Z Flexure (-X) Bot Tens	1.135 k-ft/ft	11.349 k-ft/ft	+1.20D+0.50Lr+1.60L
PASS	0.896	Min Steel X Flexure Bottom	0.259 in2/ft	0.289 in2/ft	n/a
PASS	0.6466	X Flexure (+Z) Bot Tens	7.844 k-ft/ft	12.131 k-ft/ft	+1.20D+0.50Lr+L+W
PASS	0.4169	X Flexure (-Z) Bot Tens	5.057 k-ft/ft	12.131 k-ft/ft	+1.20D+0.50Lr+1.60L
PASS	0.836	Min Steel Z Flexure Bottom	0.259 in2/ft	0.310 in2/ft	n/a
PASS	0.0	Z Flexure (+X) Top Tens	0 k-ft/ft	0.0 k-ft/ft	
PASS	0.0	Z Flexure (-X) Top Tens	0 k-ft/ft	0.0 k-ft/ft	
PASS	0.950	Min Steel X Flexure Top	0.000 in2/ft	0.000 in2/ft	n/a
PASS	0.0	X Flexure (+Z) Top Tens	0 k-ft/ft	0.0 k-ft/ft	
PASS	0.05394	X Flexure (-Z) Top Tens	0.6543 k-ft/ft	12.131 k-ft/ft	+0.90D+W
PASS	0.836	Min Steel Z Flexure Top	0.259 in2/ft	0.310 in2/ft	n/a
PASS	0.1535	1-way Shear (+X)	7.004 psi	45.643 psi	+1.20D+0.50Lr+1.60L
PASS	0.1535	1-way Shear (-X)	7.004 psi	45.643 psi	+1.20D+0.50Lr+1.60L
PASS	0.7259	1-way Shear (+Z)	33.901 psi	46.704 psi	+1.20D+0.50Lr+L+W
PASS	0.4799	1-way Shear (-Z)	22.414 psi	46.704 psi	+1.20D+0.50Lr+1.60L
PASS	0.1963	2-way Punching	32.255 psi	164.317 psi	+1.20D+0.50Lr+1.60L

Detailed Results

Soil Bearing

Rotation Axis & Load Combination...	Gross Allowable	Xecc	Zecc (in)	Actual Soil Bearing Stress @ Location				Actual / Allow Ratio
				Bottom, -Z	Top, +Z	Left, -X	Right, +X	
X-X, D Only	1.50	n/a	0.0	0.5956	0.5956	n/a	n/a	0.397
X-X, +D+L	1.50	n/a	0.0	0.8826	0.8826	n/a	n/a	0.588
X-X, +D+Lr	1.50	n/a	0.0	0.6132	0.6132	n/a	n/a	0.409
X-X, +D+0.70S	1.50	n/a	0.0	0.6056	0.6056	n/a	n/a	0.404
X-X, +D+0.750Lr+0.750L	1.50	n/a	0.0	0.8240	0.8240	n/a	n/a	0.549
X-X, +D+0.750L+0.5250S	1.50	n/a	0.0	0.8183	0.8183	n/a	n/a	0.546
X-X, +D+0.60W	1.50	n/a	15.312	0.0	1.198	n/a	n/a	0.799
X-X, +D+0.750Lr+0.750L+0.450W	1.50	n/a	8.301	0.3726	1.275	n/a	n/a	0.850
X-X, +D+0.750L+0.5250S+0.450W	1.50	n/a	8.359	0.3669	1.270	n/a	n/a	0.847
X-X, +0.60D+0.60W	1.50	n/a	25.520	0.0	1.092	n/a	n/a	0.728
X-X, +D+0.70E	1.50	n/a	12.787	0.09297	1.098	n/a	n/a	0.732
X-X, +D+0.750L+0.10S+0.5250E	1.50	n/a	7.032	0.4353	1.189	n/a	n/a	0.793
X-X, +0.60D+0.70E	1.50	n/a	21.311	0.0	0.8994	n/a	n/a	0.600
Z-Z, D Only	1.50	0.0	n/a	n/a	n/a	0.5956	0.5956	0.397
Z-Z, +D+L	1.50	0.0	n/a	n/a	n/a	0.8826	0.8826	0.588
Z-Z, +D+Lr	1.50	0.0	n/a	n/a	n/a	0.6132	0.6132	0.409
Z-Z, +D+0.70S	1.50	0.0	n/a	n/a	n/a	0.6056	0.6056	0.404
Z-Z, +D+0.750Lr+0.750L	1.50	0.0	n/a	n/a	n/a	0.8240	0.8240	0.549
Z-Z, +D+0.750L+0.5250S	1.50	0.0	n/a	n/a	n/a	0.8183	0.8183	0.546
Z-Z, +D+0.60W	1.50	0.0	n/a	n/a	n/a	0.5956	0.5956	0.397
Z-Z, +D+0.750Lr+0.750L+0.450W	1.50	0.0	n/a	n/a	n/a	0.8240	0.8240	0.549
Z-Z, +D+0.750L+0.5250S+0.450W	1.50	0.0	n/a	n/a	n/a	0.8183	0.8183	0.546
Z-Z, +0.60D+0.60W	1.50	0.0	n/a	n/a	n/a	0.3574	0.3574	0.238
Z-Z, +D+0.70E	1.50	0.0	n/a	n/a	n/a	0.5956	0.5956	0.397

Project Title:
 Engineer:
 Project ID:
 Project Descr:

General Footing

Project File:

LIC# : KW-06019737, Build:20.25.10.02

PLIRIS

(c) ENERCALC, LLC 1982-2025

DESCRIPTION: GARAGE COLUMN FOOTING

Detailed Results

Soil Bearing

Rotation Axis & Load Combination...	Gross Allowable	Xecc	Zecc (in)	Actual Soil Bearing Stress @ Location				Actual / Allow Ratio
				Bottom, -Z	Top, +Z	Left, -X	Right, +X	
Z-Z, +D+0.750L+0.10S+0.5250E	1.50	0.0	n/a	n/a	n/a	0.8123	0.8123	0.542
Z-Z, +0.60D+0.70E	1.50	0.0	n/a	n/a	n/a	0.3574	0.3574	0.238

Overtuning Stability

Rotation Axis & Load Combination...	Overtuning Moment	Resisting Moment	Stability Ratio	Status
X-X, D Only	None	0.0 k-ft	Infinity	OK
X-X, +D+L	None	0.0 k-ft	Infinity	OK
X-X, +D+Lr	None	0.0 k-ft	Infinity	OK
X-X, +D+0.70S	None	0.0 k-ft	Infinity	OK
X-X, +D+0.750Lr+0.750L	None	0.0 k-ft	Infinity	OK
X-X, +D+0.750L+0.5250S	None	0.0 k-ft	Infinity	OK
X-X, +D+0.60W	28.50 k-ft	83.759 k-ft	2.939	OK
X-X, +D+0.750Lr+0.750L+0.450W	21.375 k-ft	115.878 k-ft	5.421	OK
X-X, +D+0.750L+0.5250S+0.450W	21.375 k-ft	115.077 k-ft	5.384	OK
X-X, +0.60D+0.60W	28.50 k-ft	50.256 k-ft	1.763	OK
X-X, +D+0.70E	23.80 k-ft	83.759 k-ft	3.519	OK
X-X, +D+0.750L+0.10S+0.5250E	17.850 k-ft	114.223 k-ft	6.399	OK
X-X, +0.60D+0.70E	23.80 k-ft	50.256 k-ft	2.112	OK
Z-Z, D Only	None	0.0 k-ft	Infinity	OK
Z-Z, +D+L	None	0.0 k-ft	Infinity	OK
Z-Z, +D+Lr	None	0.0 k-ft	Infinity	OK
Z-Z, +D+0.70S	None	0.0 k-ft	Infinity	OK
Z-Z, +D+0.750Lr+0.750L	None	0.0 k-ft	Infinity	OK
Z-Z, +D+0.750L+0.5250S	None	0.0 k-ft	Infinity	OK
Z-Z, +D+0.60W	None	0.0 k-ft	Infinity	OK
Z-Z, +D+0.750Lr+0.750L+0.450W	None	0.0 k-ft	Infinity	OK
Z-Z, +D+0.750L+0.5250S+0.450W	None	0.0 k-ft	Infinity	OK
Z-Z, +0.60D+0.60W	None	0.0 k-ft	Infinity	OK
Z-Z, +D+0.70E	None	0.0 k-ft	Infinity	OK
Z-Z, +D+0.750L+0.10S+0.5250E	None	0.0 k-ft	Infinity	OK
Z-Z, +0.60D+0.70E	None	0.0 k-ft	Infinity	OK

All units k

Sliding Stability

Force Application Axis Load Combination...	Sliding Force	Resisting Force	Stability Ratio	Status
--	---------------	-----------------	-----------------	--------

Footing Has NO Sliding

Footing Flexure

Flexure Axis & Load Combination	Mu k-ft	Side	Tension Surface	As Req'd in^2	Gvrn. As in^2	Actual As in^2	Phi*Mn k-ft	Status
X-X, +1.40D	3.163	+Z	Bottom	0.2592	ACI 7.6.1.1	0.310	12.131	OK
X-X, +1.40D	3.163	-Z	Bottom	0.2592	ACI 7.6.1.1	0.310	12.131	OK
X-X, +1.20D+0.50Lr+1.60L	5.057	+Z	Bottom	0.2592	ACI 7.6.1.1	0.310	12.131	OK
X-X, +1.20D+0.50Lr+1.60L	5.057	-Z	Bottom	0.2592	ACI 7.6.1.1	0.310	12.131	OK
X-X, +1.20D+1.60L+0.30S	5.034	+Z	Bottom	0.2592	ACI 7.6.1.1	0.310	12.131	OK
X-X, +1.20D+1.60L+0.30S	5.034	-Z	Bottom	0.2592	ACI 7.6.1.1	0.310	12.131	OK
X-X, +1.20D+1.60Lr+L	4.291	+Z	Bottom	0.2592	ACI 7.6.1.1	0.310	12.131	OK
X-X, +1.20D+1.60Lr+L	4.291	-Z	Bottom	0.2592	ACI 7.6.1.1	0.310	12.131	OK
X-X, +1.20D+1.60Lr+0.50W	4.677	+Z	Bottom	0.2592	ACI 7.6.1.1	0.310	12.131	OK
X-X, +1.20D+1.60Lr+0.50W	1.027	-Z	Bottom	0.2592	ACI 7.6.1.1	0.310	12.131	OK
X-X, +1.20D+L+S	4.221	+Z	Bottom	0.2592	ACI 7.6.1.1	0.310	12.131	OK
X-X, +1.20D+L+S	4.221	-Z	Bottom	0.2592	ACI 7.6.1.1	0.310	12.131	OK
X-X, +1.20D+S+0.50W	4.608	+Z	Bottom	0.2592	ACI 7.6.1.1	0.310	12.131	OK
X-X, +1.20D+S+0.50W	0.9577	-Z	Bottom	0.2592	ACI 7.6.1.1	0.310	12.131	OK
X-X, +1.20D+0.50Lr+L+W	7.844	+Z	Bottom	0.2592	ACI 7.6.1.1	0.310	12.131	OK
X-X, +1.20D+0.50Lr+L+W	0.5437	-Z	Bottom	0.2592	ACI 7.6.1.1	0.310	12.131	OK
X-X, +1.20D+L+0.30S+W	7.822	+Z	Bottom	0.2592	ACI 7.6.1.1	0.310	12.131	OK
X-X, +1.20D+L+0.30S+W	0.5209	-Z	Bottom	0.2592	ACI 7.6.1.1	0.310	12.131	OK
X-X, +0.90D+W	6.576	+Z	Bottom	0.2592	ACI 7.6.1.1	0.310	12.131	OK
X-X, +1.20D+L+0.150S+E	6.773	+Z	Bottom	0.2592	ACI 7.6.1.1	0.310	12.131	OK
X-X, +1.20D+L+0.150S+E	1.548	-Z	Bottom	0.2592	ACI 7.6.1.1	0.310	12.131	OK
X-X, +0.90D+E	4.758	+Z	Bottom	0.2592	ACI 7.6.1.1	0.310	12.131	OK
Z-Z, +1.40D	0.7097	-X	Bottom	0.2592	ACI 7.6.1.1	0.2893	11.349	OK
Z-Z, +1.40D	0.7097	+X	Bottom	0.2592	ACI 7.6.1.1	0.2893	11.349	OK

Project Title:
 Engineer:
 Project ID:
 Project Descr:

General Footing

Project File:

LIC# : KW-06019737, Build:20.25.10.02

PLIRIS

(c) ENERCALC, LLC 1982-2025

DESCRIPTION: GARAGE COLUMN FOOTING

Footing Flexure

Flexure Axis & Load Combination	Mu k-ft	Side	Tension Surface	As Req'd in^2	Gvrn. As in^2	Actual As in^2	Phi*Mn k-ft	Status
Z-Z, +1.20D+0.50Lr+1.60L	1.135	-X	Bottom	0.2592	ACI 7.6.1.1	0.2893	11.349	OK
Z-Z, +1.20D+0.50Lr+1.60L	1.135	+X	Bottom	0.2592	ACI 7.6.1.1	0.2893	11.349	OK
Z-Z, +1.20D+1.60L+0.30S	1.130	-X	Bottom	0.2592	ACI 7.6.1.1	0.2893	11.349	OK
Z-Z, +1.20D+1.60L+0.30S	1.130	+X	Bottom	0.2592	ACI 7.6.1.1	0.2893	11.349	OK
Z-Z, +1.20D+1.60Lr+L	0.9628	-X	Bottom	0.2592	ACI 7.6.1.1	0.2893	11.349	OK
Z-Z, +1.20D+1.60Lr+L	0.9628	+X	Bottom	0.2592	ACI 7.6.1.1	0.2893	11.349	OK
Z-Z, +1.20D+1.60Lr+0.50W	0.640	-X	Bottom	0.2592	ACI 7.6.1.1	0.2893	11.349	OK
Z-Z, +1.20D+1.60Lr+0.50W	0.640	+X	Bottom	0.2592	ACI 7.6.1.1	0.2893	11.349	OK
Z-Z, +1.20D+L+S	0.9472	-X	Bottom	0.2592	ACI 7.6.1.1	0.2893	11.349	OK
Z-Z, +1.20D+L+S	0.9472	+X	Bottom	0.2592	ACI 7.6.1.1	0.2893	11.349	OK
Z-Z, +1.20D+S+0.50W	0.6244	-X	Bottom	0.2592	ACI 7.6.1.1	0.2893	11.349	OK
Z-Z, +1.20D+S+0.50W	0.6244	+X	Bottom	0.2592	ACI 7.6.1.1	0.2893	11.349	OK
Z-Z, +1.20D+0.50Lr+L+W	0.9410	-X	Bottom	0.2592	ACI 7.6.1.1	0.2893	11.349	OK
Z-Z, +1.20D+0.50Lr+L+W	0.9410	+X	Bottom	0.2592	ACI 7.6.1.1	0.2893	11.349	OK
Z-Z, +1.20D+L+0.30S+W	0.9360	-X	Bottom	0.2592	ACI 7.6.1.1	0.2893	11.349	OK
Z-Z, +1.20D+L+0.30S+W	0.9360	+X	Bottom	0.2592	ACI 7.6.1.1	0.2893	11.349	OK
Z-Z, +0.90D+W	0.4563	-X	Bottom	0.2592	ACI 7.6.1.1	0.2893	11.349	OK
Z-Z, +0.90D+W	0.4563	+X	Bottom	0.2592	ACI 7.6.1.1	0.2893	11.349	OK
Z-Z, +1.20D+L+0.150S+E	0.9336	-X	Bottom	0.2592	ACI 7.6.1.1	0.2893	11.349	OK
Z-Z, +1.20D+L+0.150S+E	0.9336	+X	Bottom	0.2592	ACI 7.6.1.1	0.2893	11.349	OK
Z-Z, +0.90D+E	0.4563	-X	Bottom	0.2592	ACI 7.6.1.1	0.2893	11.349	OK
Z-Z, +0.90D+E	0.4563	+X	Bottom	0.2592	ACI 7.6.1.1	0.2893	11.349	OK

Footing Flexure

Flexure Axis & Load Combination	Mu k-ft	Side	Tension Surface	As Req'd in^2	Gvrn. As in^2	Actual As in^2	Phi*Mn k-ft	Status
X-X, +0.90D+W	0.6543	-Z	Top	0.2592	ACI 7.6.1.1	0.310	12.131	OK
X-X, +0.90D+E	0.4345	-Z	Top	0.2592	ACI 7.6.1.1	0.310	12.131	OK

One Way Shear X

Load Combination...	Vu @ -X	Vu @ +X	Vu:Max	Phi Vn	Vu / Phi*Vn	Status
+1.40D	4.38 psi	4.38 psi	4.38 psi	45.64 psi	0.10	OK
+1.20D+0.50Lr+1.60L	7.00 psi	7.00 psi	7.00 psi	45.64 psi	0.15	OK
+1.20D+1.60L+0.30S	6.97 psi	6.97 psi	6.97 psi	45.64 psi	0.15	OK
+1.20D+1.60Lr+L	5.94 psi	5.94 psi	5.94 psi	45.64 psi	0.13	OK
+1.20D+1.60Lr+0.50W	3.95 psi	3.95 psi	3.95 psi	45.64 psi	0.09	OK
+1.20D+L+S	5.85 psi	5.85 psi	5.85 psi	45.64 psi	0.13	OK
+1.20D+S+0.50W	3.85 psi	3.85 psi	3.85 psi	45.64 psi	0.08	OK
+1.20D+0.50Lr+L+W	5.81 psi	5.81 psi	5.81 psi	45.64 psi	0.13	OK
+1.20D+L+0.30S+W	5.78 psi	5.78 psi	5.78 psi	45.64 psi	0.13	OK
+0.90D+W	2.82 psi	2.82 psi	2.82 psi	45.64 psi	0.06	OK
+1.20D+L+0.150S+E	5.76 psi	5.76 psi	5.76 psi	45.64 psi	0.13	OK
+0.90D+E	2.82 psi	2.82 psi	2.82 psi	45.64 psi	0.06	OK

One Way Shear Z

Load Combination...	Vu @ -Z	Vu @ +Z	Vu:Max	Phi Vn	Vu / Phi*Vn	Status
+1.40D	14.02 psi	14.02 psi	14.02 psi	46.70 psi	0.30	OK
+1.20D+0.50Lr+1.60L	22.41 psi	22.41 psi	22.41 psi	46.70 psi	0.48	OK
+1.20D+1.60L+0.30S	22.31 psi	22.31 psi	22.31 psi	46.70 psi	0.48	OK
+1.20D+1.60Lr+L	19.02 psi	19.02 psi	19.02 psi	46.70 psi	0.41	OK
+1.20D+1.60Lr+0.50W	4.99 psi	20.30 psi	20.30 psi	46.70 psi	0.43	OK
+1.20D+L+S	18.71 psi	18.71 psi	18.71 psi	46.70 psi	0.40	OK
+1.20D+S+0.50W	4.68 psi	19.99 psi	19.99 psi	46.70 psi	0.43	OK
+1.20D+0.50Lr+L+W	3.28 psi	33.90 psi	33.90 psi	46.70 psi	0.73	OK
+1.20D+L+0.30S+W	3.18 psi	33.80 psi	33.80 psi	46.70 psi	0.72	OK
+0.90D+W	2.90 psi	27.66 psi	27.66 psi	46.70 psi	0.59	OK
+1.20D+L+0.150S+E	7.48 psi	29.40 psi	29.40 psi	46.70 psi	0.63	OK
+0.90D+E	1.77 psi	20.41 psi	20.41 psi	46.70 psi	0.44	OK

Two-Way "Punching" Shear

Load Combination...	Vu	Phi*Vn	Vu / Phi*Vn	Status
+1.40D	20.18 psi	164.32 psi	0.12	OK
+1.20D+0.50Lr+1.60L	32.26 psi	164.32 psi	0.20	OK
+1.20D+1.60L+0.30S	32.11 psi	164.32 psi	0.20	OK
+1.20D+1.60Lr+L	27.37 psi	164.32 psi	0.17	OK
+1.20D+1.60Lr+0.50W	18.19 psi	164.32 psi	0.11	OK
+1.20D+L+S	26.93 psi	164.32 psi	0.16	OK

All units k

Project Title:
Engineer:
Project ID:
Project Descr:

General Footing

Project File:

LIC# : KW-06019737, Build:20.25.10.02

PLIRIS

(c) ENERCALC, LLC 1982-2025

DESCRIPTION: GARAGE COLUMN FOOTING

Two-Way "Punching" Shear

All units k

Load Combination...	Vu	Phi*Vn	Vu / Phi*Vn	Status
+1.20D+S+0.50W	17.75 psi	164.32 psi	0.11	OK
+1.20D+0.50Lr+L+W	26.75 psi	164.32 psi	0.16	OK
+1.20D+L+0.30S+W	26.61 psi	164.32 psi	0.16	OK
+0.90D+W	14.57 psi	164.32 psi	0.09	OK
+1.20D+L+0.150S+E	26.54 psi	164.32 psi	0.16	OK
+0.90D+E	13.10 psi	164.32 psi	0.08	OK

Project Title:
 Engineer:
 Project ID:
 Project Descr:

General Footing

Project File:

LIC# : KW-06019737, Build:20.25.10.02

PLIRIS

(c) ENERCALC, LLC 1982-2025

DESCRIPTION: FOOTING AT BACKSIDE OF COMMERCIAL SPACE

Code References

Governing Code : IBC 2021
 Referenced Design Standard(s) : ACI 318-19
 Load Combinations Used : ASCE 7-22 / IBC 2024

General Information

Material Properties

f'c : Concrete 28 day strength	=	3.0 ksi
fy : Rebar Yield	=	60.0 ksi
Ec : Concrete Elastic Modulus	=	3,122.0 ksi
Concrete Density	=	145.0 pcf
φ Values Flexure	=	0.90
Shear	=	0.750

Analysis Settings

Min Steel % Bending Reinf.	=	
Min Allow % Temp Reinf.	=	
Min. Overturning Safety Factor	=	1.0 : 1
Min. Sliding Safety Factor	=	1.0 : 1
Add Ftg Wt for Soil Pressure	:	Yes
Use ftg wt for stability, moments & shears	:	Yes
Add Pedestal Wt for Soil Pressure	:	Yes
Use Pedestal wt for stability, mom & shear	:	No

Soil Design Values

Allowable Soil Bearing	=	1.50 ksf
Soil Density	=	110.0 pcf
Increase Bearing By Footing Weight	=	No
Soil Passive Resistance (for Sliding)	=	250.0 pcf
Soil/Concrete Friction Coeff.	=	0.30

Increases based on footing Depth

Footing base depth below soil surface	=	ft
Allow press. increase per foot of depth when footing base is below	=	ksf ft

Increases based on footing plan dimension

Allowable pressure increase per foot of depth when max. length or width is greater than	=	ksf ft
---	---	-----------

Dimensions

Width parallel to X-X Axis	=	6.25 ft
Length parallel to Z-Z Axis	=	6.25 ft
Footing Thickness	=	15.0 in

Pedestal dimensions...

px : parallel to X-X Axis	=	12.0 in
pz : parallel to Z-Z Axis	=	8.0 in
Height	=	48.0 in

Bandwidth Distribution Check (ACI 15.4.4.2)

Direction Requiring Closer Separation	n/a
# Bars required within zone	n/a
# Bars required on each side of zone	n/a

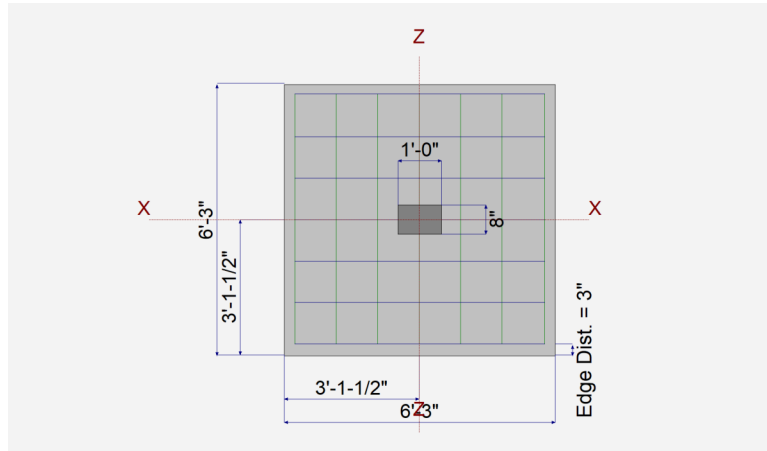

Bottom Reinforcing

Bars parallel to X-X Axis (resisting Z Flexure)		
Number of Bars	=	7
Reinforcing Bar Size	=	# 5
Bars parallel to Z-Z Axis (resisting X Flexure)		
Number of Bars	=	7
Reinforcing Bar Size	=	# 5
Rebar Centerline to Edge of Concrete... at Bottom of footing	=	3.0 in

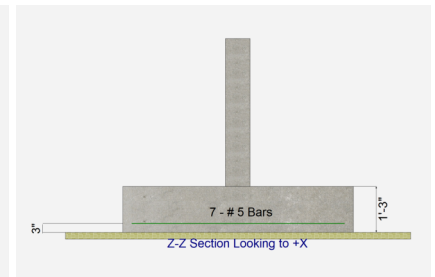

Top Reinforcing

Bars parallel to X-X Axis (resisting Z Flexure)		
Number of Bars	=	7
Reinforcing Bar Size	=	5
Bars parallel to Z-Z Axis (resisting X Flexure)		
Number of Bars	=	8
Reinforcing Bar Size	=	5
Rebar Centerline to Edge of Concrete... at Top of footing	=	3.0 in

Project Title:
 Engineer:
 Project ID:
 Project Descr:

General Footing

Project File:

LIC# : KW-06019737, Build:20.25.10.02

PLIRIS

(c) ENERCALC, LLC 1982-2025

DESCRIPTION: FOOTING AT BACKSIDE OF COMMERCIAL SPACE

Applied Loads

	D	Lr	L	S	W	E	H
P : Column Load	=	18.0		31.50			k
OB : Overburden	=						ksf
M-xx	=						k-ft
M-zz	=						k-ft
V-x	=						k
V-z	=						k

DESIGN SUMMARY

Design OK

	Min. Ratio	Item	Applied	Capacity	Governing Load Combination
PASS	0.9720	Soil Bearing	1.458 ksf	1.50 ksf	+D+L about Z-Z axis
PASS	n/a	Overturing - X-X	0.0 k-ft	0.0 k-ft	No Overturing
PASS	n/a	Overturing - Z-Z	0.0 k-ft	0.0 k-ft	No Overturing
PASS	n/a	Sliding - X-X	0.0 k	0.0 k	No Sliding
PASS	n/a	Sliding - Z-Z	0.0 k	0.0 k	No Sliding
PASS	n/a	Uplift	0.0 k	0.0 k	No Uplift
PASS	0.3508	Z Flexure (+X) Bot Tens	6.391 k-ft/ft	18.217 k-ft/ft	+1.20D+1.60L
PASS	0.3508	Z Flexure (-X) Bot Tens	6.391 k-ft/ft	18.217 k-ft/ft	+1.20D+1.60L
PASS	0.933	Min Steel X Flexure Bottom	0.324 in2/ft	0.347 in2/ft	n/a
PASS	0.3968	X Flexure (+Z) Bot Tens	7.228 k-ft/ft	18.217 k-ft/ft	+1.20D+1.60L
PASS	0.3968	X Flexure (-Z) Bot Tens	7.228 k-ft/ft	18.217 k-ft/ft	+1.20D+1.60L
PASS	0.933	Min Steel Z Flexure Bottom	0.324 in2/ft	0.347 in2/ft	n/a
PASS	0.0	Z Flexure (+X) Top Tens	0 k-ft/ft	0.0 k-ft/ft	
PASS	0.0	Z Flexure (-X) Top Tens	0 k-ft/ft	0.0 k-ft/ft	
PASS	0.950	Min Steel X Flexure Top	0.000 in2/ft	0.000 in2/ft	n/a
PASS	0.0	X Flexure (+Z) Top Tens	0 k-ft/ft	0.0 k-ft/ft	
PASS	0.0	X Flexure (-Z) Top Tens	0 k-ft/ft	0.0 k-ft/ft	
PASS	0.000	Min Steel Z Flexure Top	0.000 in2/ft	0.000 in2/ft	n/a
PASS	0.4750	1-way Shear (+X)	20.934 psi	44.067 psi	+1.20D+1.60L
PASS	0.4750	1-way Shear (-X)	20.934 psi	44.067 psi	+1.20D+1.60L
PASS	0.5299	1-way Shear (+Z)	23.350 psi	44.067 psi	+1.20D+1.60L
PASS	0.5299	1-way Shear (-Z)	23.350 psi	44.067 psi	+1.20D+1.60L
PASS	0.3829	2-way Punching	62.912 psi	164.317 psi	+1.20D+1.60L

Detailed Results

Soil Bearing

Rotation Axis & Load Combination...	Gross Allowable	Xeccc	Zecc (in)	Actual Soil Bearing Stress @ Location				Actual / Allow Ratio
				Bottom, -Z	Top, +Z	Left, -X	Right, +X	
X-X, D Only	1.50	n/a	0.0	0.6519	0.6519	n/a	n/a	0.435
X-X, +D+L	1.50	n/a	0.0	1.458	1.458	n/a	n/a	0.972
X-X, +D+0.750L	1.50	n/a	0.0	1.257	1.257	n/a	n/a	0.838
X-X, +0.60D	1.50	n/a	0.0	0.3912	0.3912	n/a	n/a	0.261
Z-Z, D Only	1.50	0.0	n/a	n/a	n/a	0.6519	0.6519	0.435
Z-Z, +D+L	1.50	0.0	n/a	n/a	n/a	1.458	1.458	0.972
Z-Z, +D+0.750L	1.50	0.0	n/a	n/a	n/a	1.257	1.257	0.838
Z-Z, +0.60D	1.50	0.0	n/a	n/a	n/a	0.3912	0.3912	0.261

Overturing Stability

Rotation Axis & Load Combination...	Overturing Moment	Resisting Moment	Stability Ratio	Status
Footing Has NO Overturing				

All units k

Sliding Stability

Force Application Axis Load Combination...	Sliding Force	Resisting Force	Stability Ratio	Status
Footing Has NO Sliding				

Footing Flexure

Flexure Axis & Load Combination	Mu k-ft	Side	Tension Surface	As Req'd in^2	Gvrn. As in^2	Actual As in^2	Phi*Mn k-ft	Status
X-X, +1.40D	2.568	+Z	Bottom	0.3240	ACI 7.6.1.1	0.3472	18.217	OK

Project Title:
 Engineer:
 Project ID:
 Project Descr:

General Footing

Project File:

LIC# : KW-06019737, Build:20.25.10.02

PLIRIS

(c) ENERCALC, LLC 1982-2025

DESCRIPTION: FOOTING AT BACKSIDE OF COMMERCIAL SPACE

Footing Flexure

Flexure Axis & Load Combination	Mu k-ft	Side	Tension Surface	As Req'd in^2	Gvrn. As in^2	Actual As in^2	Phi*Mn k-ft	Status
X-X, +1.40D	2.568	-Z	Bottom	0.3240	ACI 7.6.1.1	0.3472	18.217	OK
X-X, +1.20D+1.60L	7.228	+Z	Bottom	0.3240	ACI 7.6.1.1	0.3472	18.217	OK
X-X, +1.20D+1.60L	7.228	-Z	Bottom	0.3240	ACI 7.6.1.1	0.3472	18.217	OK
X-X, +1.20D+L	5.343	+Z	Bottom	0.3240	ACI 7.6.1.1	0.3472	18.217	OK
X-X, +1.20D+L	5.343	-Z	Bottom	0.3240	ACI 7.6.1.1	0.3472	18.217	OK
X-X, +1.20D	2.201	+Z	Bottom	0.3240	ACI 7.6.1.1	0.3472	18.217	OK
X-X, +1.20D	2.201	-Z	Bottom	0.3240	ACI 7.6.1.1	0.3472	18.217	OK
X-X, +0.90D	1.651	+Z	Bottom	0.3240	ACI 7.6.1.1	0.3472	18.217	OK
X-X, +0.90D	1.651	-Z	Bottom	0.3240	ACI 7.6.1.1	0.3472	18.217	OK
Z-Z, +1.40D	2.270	-X	Bottom	0.3240	ACI 7.6.1.1	0.3472	18.217	OK
Z-Z, +1.40D	2.270	+X	Bottom	0.3240	ACI 7.6.1.1	0.3472	18.217	OK
Z-Z, +1.20D+1.60L	6.391	-X	Bottom	0.3240	ACI 7.6.1.1	0.3472	18.217	OK
Z-Z, +1.20D+1.60L	6.391	+X	Bottom	0.3240	ACI 7.6.1.1	0.3472	18.217	OK
Z-Z, +1.20D+L	4.724	-X	Bottom	0.3240	ACI 7.6.1.1	0.3472	18.217	OK
Z-Z, +1.20D+L	4.724	+X	Bottom	0.3240	ACI 7.6.1.1	0.3472	18.217	OK
Z-Z, +1.20D	1.946	-X	Bottom	0.3240	ACI 7.6.1.1	0.3472	18.217	OK
Z-Z, +1.20D	1.946	+X	Bottom	0.3240	ACI 7.6.1.1	0.3472	18.217	OK
Z-Z, +0.90D	1.460	-X	Bottom	0.3240	ACI 7.6.1.1	0.3472	18.217	OK
Z-Z, +0.90D	1.460	+X	Bottom	0.3240	ACI 7.6.1.1	0.3472	18.217	OK

Footing Flexure

Flexure Axis & Load Combination	Mu k-ft	Side	Tension Surface	As Req'd in^2	Gvrn. As in^2	Actual As in^2	Phi*Mn k-ft	Status
---------------------------------	------------	------	--------------------	------------------	------------------	-------------------	----------------	--------

One Way Shear X

Load Combination...	Vu @ -X	Vu @ +X	Vu:Max	Phi Vn	Vu / Phi*Vn	Status
+1.40D	7.44 psi	7.44 psi	7.44 psi	44.07 psi	0.17	OK
+1.20D+1.60L	20.93 psi	20.93 psi	20.93 psi	44.07 psi	0.48	OK
+1.20D+L	15.47 psi	15.47 psi	15.47 psi	44.07 psi	0.35	OK
+1.20D	6.37 psi	6.37 psi	6.37 psi	44.07 psi	0.14	OK
+0.90D	4.78 psi	4.78 psi	4.78 psi	44.07 psi	0.11	OK

One Way Shear Z

Load Combination...	Vu @ -Z	Vu @ +Z	Vu:Max	Phi Vn	Vu / Phi*Vn	Status
+1.40D	8.29 psi	8.29 psi	8.29 psi	44.07 psi	0.19	OK
+1.20D+1.60L	23.35 psi	23.35 psi	23.35 psi	44.07 psi	0.53	OK
+1.20D+L	17.26 psi	17.26 psi	17.26 psi	44.07 psi	0.39	OK
+1.20D	7.11 psi	7.11 psi	7.11 psi	44.07 psi	0.16	OK
+0.90D	5.33 psi	5.33 psi	5.33 psi	44.07 psi	0.12	OK

Two-Way "Punching" Shear

Load Combination...	Vu	Phi*Vn	Vu / Phi*Vn	Status
+1.40D	22.35 psi	164.32 psi	0.14	OK
+1.20D+1.60L	62.91 psi	164.32 psi	0.38	OK
+1.20D+L	46.50 psi	164.32 psi	0.28	OK
+1.20D	19.16 psi	164.32 psi	0.12	OK
+0.90D	14.37 psi	164.32 psi	0.09	OK

All units k

Project Title:
 Engineer:
 Project ID:
 Project Descr:

General Footing

Project File:

LIC# : KW-06019737, Build:20.25.10.02

PLIRIS

(c) ENERCALC, LLC 1982-2025

DESCRIPTION: CENTER FRAME - PIER PAD

Code References

Governing Code : IBC 2021
 Referenced Design Standard(s) : ACI 318-19
 Load Combinations Used : ASCE 7-22 / IBC 2024

General Information

Material Properties

f'c : Concrete 28 day strength	=	3.0 ksi
fy : Rebar Yield	=	60.0 ksi
Ec : Concrete Elastic Modulus	=	3,122.0 ksi
Concrete Density	=	145.0 pcf
φ Values Flexure	=	0.90
Shear	=	0.750

Analysis Settings

Min Steel % Bending Reinf.	=	
Min Allow % Temp Reinf.	=	
Min. Overturning Safety Factor	=	1.0 : 1
Min. Sliding Safety Factor	=	1.0 : 1
Add Ftg Wt for Soil Pressure	:	Yes
Use ftg wt for stability, moments & shears	:	Yes
Add Pedestal Wt for Soil Pressure	:	Yes
Use Pedestal wt for stability, mom & shear	:	Yes

Soil Design Values

Allowable Soil Bearing	=	1.50 ksf
Soil Density	=	110.0 pcf
Increase Bearing By Footing Weight	=	No
Soil Passive Resistance (for Sliding)	=	250.0 pcf
Soil/Concrete Friction Coeff.	=	0.30

Increases based on footing Depth

Footing base depth below soil surface	=	ft
Allow press. increase per foot of depth when footing base is below	=	ksf ft

Increases based on footing plan dimension

Allowable pressure increase per foot of depth when max. length or width is greater than	=	ksf ft
---	---	-----------

Dimensions

Width parallel to X-X Axis	=	10.0 ft
Length parallel to Z-Z Axis	=	10.0 ft
Footing Thickness	=	15.0 in

Pedestal dimensions...

px : parallel to X-X Axis	=	24.0 in
pz : parallel to Z-Z Axis	=	10.0 in
Height	=	18.0 in

Bandwidth Distribution Check (ACI 15.4.4.2)

Direction Requiring Closer Separation
 # Bars required within zone
 # Bars required on each side of zone

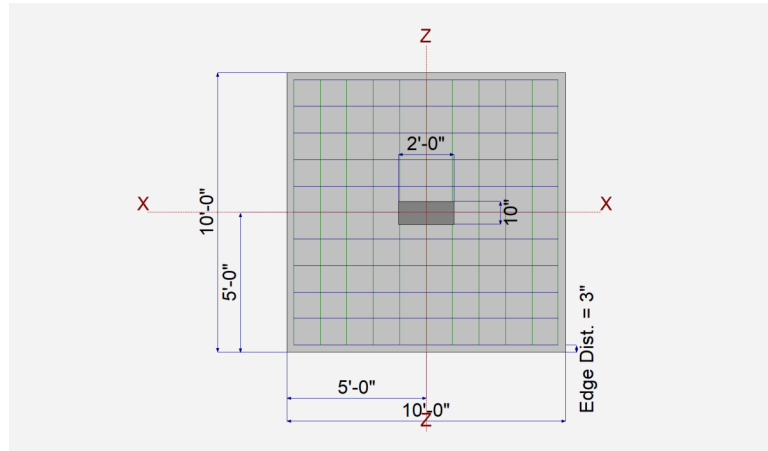

Bottom Reinforcing

Bars parallel to X-X Axis (resisting Z Flexure)		
Number of Bars	=	11.0
Reinforcing Bar Size	= #	5
Bars parallel to Z-Z Axis (resisting X Flexure)		
Number of Bars	=	11.0
Reinforcing Bar Size	= #	5
Rebar Centerline to Edge of Concrete... at Bottom of footing	=	3.0 in

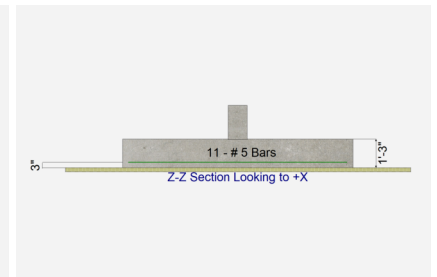
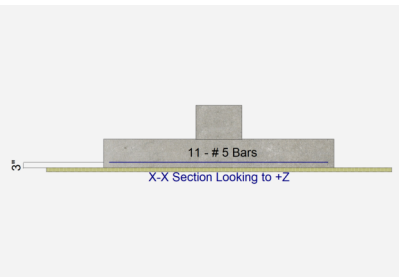

Top Reinforcing

Bars parallel to X-X Axis (resisting Z Flexure)		
Number of Bars	=	11.0
Reinforcing Bar Size	=	5
Bars parallel to Z-Z Axis (resisting X Flexure)		
Number of Bars	=	11.0
Reinforcing Bar Size	=	5
Rebar Centerline to Edge of Concrete... at Top of footing	=	3.0 in

Project Title:
 Engineer:
 Project ID:
 Project Descr:

General Footing

Project File:

LIC# : KW-06019737, Build:20.25.10.02

PLIRIS

(c) ENERCALC, LLC 1982-2025

DESCRIPTION: CENTER FRAME - PIER PAD

Applied Loads

	D	Lr	L	S	W	E	H
P : Column Load	=		99.620				k
OB : Overburden	=						ksf
M-xx	=						k-ft
M-zz	=				55.770		k-ft
V-x	=	2.864					k
V-z	=						k

DESIGN SUMMARY

Design N.G.

Min. Ratio	Item	Applied	Capacity	Governing Load Combination
PASS	Soil Bearing	ksf	ksf	
FAIL	Overturing - X-X	k-ft	k-ft	
FAIL	Overturing - Z-Z	k-ft	k-ft	
FAIL	Sliding - X-X	k	k	
FAIL	Sliding - Z-Z	k	k	
FAIL	Uplift	k	k	
PASS	Z Flexure (+X) Bot Tens	k-ft/ft	k-ft/ft	
PASS	Z Flexure (-X) Bot Tens	k-ft/ft	k-ft/ft	
PASS	0.950 Min Steel X Flexure Bottom	0.000 in2/ft	0.000 in2/ft	n/a
PASS	X Flexure (+Z) Bot Tens	k-ft/ft	k-ft/ft	
PASS	X Flexure (-Z) Bot Tens	k-ft/ft	k-ft/ft	
PASS	0.950 Min Steel Z Flexure Bottom	0.000 in2/ft	0.000 in2/ft	n/a
PASS	Z Flexure (+X) Top Tens	k-ft/ft	k-ft/ft	
PASS	Z Flexure (-X) Top Tens	k-ft/ft	k-ft/ft	
PASS	0.950 Min Steel X Flexure Top	0.000 in2/ft	0.000 in2/ft	n/a
PASS	X Flexure (+Z) Top Tens	k-ft/ft	k-ft/ft	
PASS	X Flexure (-Z) Top Tens	k-ft/ft	k-ft/ft	
PASS	0.000 Min Steel Z Flexure Top	0.000 in2/ft	0.000 in2/ft	n/a
PASS	1-way Shear (+X)	psi	psi	
PASS	1-way Shear (-X)	psi	psi	
PASS	1-way Shear (+Z)	psi	psi	
PASS	1-way Shear (-Z)	psi	psi	
PASS	2-way Punching	psi	psi	

Detailed Results

Soil Bearing

Rotation Axis & Load Combination...	Gross Allowable	Xecc	Zecc (in)	Actual Soil Bearing Stress @ Location				Actual / Allow Ratio
				Bottom, -Z	Top, +Z	Left, -X	Right, +X	
X-X, D Only	1.50	n/a	0.0	0.1849	0.1849	n/a	n/a	0.123
X-X, +D+L	1.50	n/a	0.0	1.181	1.181	n/a	n/a	0.787
X-X, +D+0.750L	1.50	n/a	0.0	0.9320	0.9320	n/a	n/a	0.621
X-X, +D+0.60W	1.50	n/a	0.0	0.1849	0.1849	n/a	n/a	0.123
X-X, +D+0.750L+0.450W	1.50	n/a	0.0	0.9320	0.9320	n/a	n/a	0.621
X-X, +0.60D+0.60W	1.50	n/a	0.0	0.1109	0.1109	n/a	n/a	0.074
X-X, +0.60D	1.50	n/a	0.0	0.1109	0.1109	n/a	n/a	0.074
Z-Z, D Only	1.50	5.112	n/a	n/a	n/a	0.1381	0.2317	0.155
Z-Z, +D+L	1.50	0.8002	n/a	n/a	n/a	1.134	1.228	0.819
Z-Z, +D+0.750L	1.50	1.014	n/a	n/a	n/a	0.8852	0.9788	0.653
Z-Z, +D+0.60W	1.50	26.832	n/a	n/a	n/a	0.0	0.4432	0.296
Z-Z, +D+0.750L+0.450W	1.50	4.245	n/a	n/a	n/a	0.7362	1.128	0.752
Z-Z, +0.60D+0.60W	1.50	41.312	n/a	n/a	n/a	0.0	0.4698	0.313
Z-Z, +0.60D	1.50	5.112	n/a	n/a	n/a	0.08286	0.1390	0.093

Overturing Stability

Rotation Axis & Load Combination...	Overturing Moment	Resisting Moment	Stability Ratio	Status
X-X, D Only	None	0.0 k-ft	Infinity	OK
X-X, +D+L	None	0.0 k-ft	Infinity	OK
X-X, +D+0.750L	None	0.0 k-ft	Infinity	OK
X-X, +D+0.60W	None	0.0 k-ft	Infinity	OK
X-X, +D+0.750L+0.450W	None	0.0 k-ft	Infinity	OK
X-X, +0.60D+0.60W	None	0.0 k-ft	Infinity	OK

Project Title:
 Engineer:
 Project ID:
 Project Descr:

General Footing

Project File:

LIC# : KW-06019737, Build:20.25.10.02

PLIRIS

(c) ENERCALC, LLC 1982-2025

DESCRIPTION: CENTER FRAME - PIER PAD

Overturning Stability

Rotation Axis & Load Combination...	Overturning Moment	Resisting Moment	Stability Ratio	Status
X-X, +0.60D	None	0.0 k-ft	Infinity	OK
Z-Z, D Only	7.876 k-ft	92.438 k-ft	11.737	OK
Z-Z, +D+L	7.876 k-ft	590.54 k-ft	74.979	OK
Z-Z, +D+0.750L	7.876 k-ft	466.013 k-ft	59.169	OK
Z-Z, +D+0.60W	41.338 k-ft	92.438 k-ft	2.236	OK
Z-Z, +D+0.750L+0.450W	32.973 k-ft	466.013 k-ft	14.133	OK
Z-Z, +0.60D+0.60W	38.188 k-ft	55.463 k-ft	1.452	OK
Z-Z, +0.60D	4.726 k-ft	55.463 k-ft	11.737	OK

All units k

Sliding Stability

Force Application Axis Load Combination...	Sliding Force	Resisting Force	Stability Ratio	Status
X-X, D Only	2.864 k	5.546 k	1.937	OK
X-X, +D+L	2.864 k	35.432 k	12.372	OK
X-X, +D+0.750L	2.864 k	27.961 k	9.763	OK
X-X, +D+0.60W	2.864 k	5.546 k	1.937	OK
X-X, +D+0.750L+0.450W	2.864 k	27.961 k	9.763	OK
X-X, +0.60D+0.60W	1.718 k	3.328 k	1.937	OK
X-X, +0.60D	1.718 k	3.328 k	1.937	OK
Z-Z, D Only	0.0 k	5.546 k	No Sliding	OK
Z-Z, +D+L	0.0 k	35.432 k	No Sliding	OK
Z-Z, +D+0.750L	0.0 k	27.961 k	No Sliding	OK
Z-Z, +D+0.60W	0.0 k	5.546 k	No Sliding	OK
Z-Z, +D+0.750L+0.450W	0.0 k	27.961 k	No Sliding	OK
Z-Z, +0.60D+0.60W	0.0 k	3.328 k	No Sliding	OK
Z-Z, +0.60D	0.0 k	3.328 k	No Sliding	OK

Footing Flexure

Flexure Axis & Load Combination	Mu k-ft	Side	Tension Surface	As Req'd in^2	Gvrn. As in^2	Actual As in^2	Phi*Mn k-ft	Status
X-X, +1.40D	0.05330	+Z	Bottom	0.3240	ACI 7.6.1.1	0.3410	17.901	OK
X-X, +1.40D	0.05330	-Z	Bottom	0.3240	ACI 7.6.1.1	0.3410	17.901	OK
X-X, +1.20D+1.60L	16.787	+Z	Bottom	0.3240	ACI 7.6.1.1	0.3410	17.901	OK
X-X, +1.20D+1.60L	16.787	-Z	Bottom	0.3240	ACI 7.6.1.1	0.3410	17.901	OK
X-X, +1.20D+L	10.509	+Z	Bottom	0.3240	ACI 7.6.1.1	0.3410	17.901	OK
X-X, +1.20D+L	10.509	-Z	Bottom	0.3240	ACI 7.6.1.1	0.3410	17.901	OK
X-X, +1.20D+0.50W	0.04569	+Z	Bottom	0.3240	ACI 7.6.1.1	0.3410	17.901	OK
X-X, +1.20D+0.50W	0.04569	-Z	Bottom	0.3240	ACI 7.6.1.1	0.3410	17.901	OK
X-X, +1.20D+L+W	10.509	+Z	Bottom	0.3240	ACI 7.6.1.1	0.3410	17.901	OK
X-X, +1.20D+L+W	10.509	-Z	Bottom	0.3240	ACI 7.6.1.1	0.3410	17.901	OK
X-X, +0.90D+W	0.03427	+Z	Bottom	0.3240	ACI 7.6.1.1	0.3410	17.901	OK
X-X, +0.90D+W	0.03427	-Z	Bottom	0.3240	ACI 7.6.1.1	0.3410	17.901	OK
X-X, +0.90D	0.03427	+Z	Bottom	0.3240	ACI 7.6.1.1	0.3410	17.901	OK
X-X, +0.90D	0.03427	-Z	Bottom	0.3240	ACI 7.6.1.1	0.3410	17.901	OK
Z-Z, +1.40D	0.4287	+X	Bottom	0.3240	ACI 7.6.1.1	0.3410	17.901	OK
Z-Z, +1.20D+1.60L	12.454	-X	Bottom	0.3240	ACI 7.6.1.1	0.3410	17.901	OK
Z-Z, +1.20D+1.60L	13.119	+X	Bottom	0.3240	ACI 7.6.1.1	0.3410	17.901	OK
Z-Z, +1.20D+L	7.672	-X	Bottom	0.3240	ACI 7.6.1.1	0.3410	17.901	OK
Z-Z, +1.20D+L	8.337	+X	Bottom	0.3240	ACI 7.6.1.1	0.3410	17.901	OK
Z-Z, +1.20D+0.50W	1.349	+X	Bottom	0.3240	ACI 7.6.1.1	0.3410	17.901	OK
Z-Z, +1.20D+L+W	5.709	-X	Bottom	0.3240	ACI 7.6.1.1	0.3410	17.901	OK
Z-Z, +1.20D+L+W	10.30	+X	Bottom	0.3240	ACI 7.6.1.1	0.3410	17.901	OK
Z-Z, +0.90D+W	3.316	+X	Bottom	0.3240	ACI 7.6.1.1	0.3410	17.901	OK
Z-Z, +0.90D	0.2756	+X	Bottom	0.3240	ACI 7.6.1.1	0.3410	17.901	OK

Footing Flexure

Flexure Axis & Load Combination	Mu k-ft	Side	Tension Surface	As Req'd in^2	Gvrn. As in^2	Actual As in^2	Phi*Mn k-ft	Status
Z-Z, +1.40D	0.3475	-X	Top	0.3240	ACI 7.6.1.1	0.3410	17.901	OK
Z-Z, +1.20D+0.50W	1.279	-X	Top	0.3240	ACI 7.6.1.1	0.3410	17.901	OK
Z-Z, +0.90D+W	1.305	-X	Top	0.3240	ACI 7.6.1.1	0.3410	17.901	OK
Z-Z, +0.90D	0.2234	-X	Top	0.3240	ACI 7.6.1.1	0.3410	17.901	OK

One Way Shear X

Load Combination...	Vu @ -X	Vu @ +X	Vu:Max	Phi Vn	Vu / Phi*Vn	Status
+1.40D	0.86 psi	1.07 psi	1.07 psi	43.80 psi	0.02	OK

Project Title:
 Engineer:
 Project ID:
 Project Descr:

General Footing

Project File:

LIC# : KW-06019737, Build:20.25.10.02

PLIRIS

(c) ENERCALC, LLC 1982-2025

DESCRIPTION: CENTER FRAME - PIER PAD

One Way Shear X

Load Combination...	Vu @ -X	Vu @ +X	Vu:Max	Phi Vn	Vu / Phi*Vn	Status
+1.20D+1.60L	32.47 psi	34.12 psi	34.12 psi	43.80 psi	0.78	OK
+1.20D+L	20.02 psi	21.67 psi	21.67 psi	43.80 psi	0.49	OK
+1.20D+0.50W	3.18 psi	3.36 psi	3.36 psi	43.80 psi	0.08	OK
+1.20D+L+W	15.14 psi	26.55 psi	26.55 psi	43.80 psi	0.61	OK
+0.90D+W	3.40 psi	7.77 psi	7.77 psi	43.80 psi	0.18	OK
+0.90D	0.55 psi	0.69 psi	0.69 psi	43.80 psi	0.02	OK

One Way Shear Z

Load Combination...	Vu @ -Z	Vu @ +Z	Vu:Max	Phi Vn	Vu / Phi*Vn	Status
+1.40D	0.13 psi	0.13 psi	0.13 psi	43.80 psi	0.00	OK
+1.20D+1.60L	39.96 psi	39.96 psi	39.96 psi	43.80 psi	0.91	OK
+1.20D+L	25.01 psi	25.01 psi	25.01 psi	43.80 psi	0.57	OK
+1.20D+0.50W	0.11 psi	0.11 psi	0.11 psi	43.80 psi	0.00	OK
+1.20D+L+W	25.01 psi	25.01 psi	25.01 psi	43.80 psi	0.57	OK
+0.90D+W	0.08 psi	0.08 psi	0.08 psi	43.80 psi	0.00	OK
+0.90D	0.08 psi	0.08 psi	0.08 psi	43.80 psi	0.00	OK

Two-Way "Punching" Shear

Load Combination...	Vu	Phi*Vn	Vu / Phi*Vn	Status
+1.40D	0.34 psi	150.62 psi	0.00	OK
+1.20D+1.60L	108.62 psi	150.62 psi	0.72	OK
+1.20D+L	68.00 psi	150.62 psi	0.45	OK
+1.20D+0.50W	0.30 psi	150.62 psi	0.00	OK
+1.20D+L+W	68.00 psi	150.62 psi	0.45	OK
+0.90D+W	0.87 psi	150.62 psi	0.01	OK
+0.90D	0.22 psi	150.62 psi	0.00	OK

All units k